

COMPARATIVE STUDY OF VARIOUS SUPERMARKET REFRIGERATING SYSTEMS IN EUROPEAN CLIMATE CONTEXT

**Paride Gullo^(a), Nilesh Purohit^(b), Mani Sankar Dasgupta^(b), Armin Hafner^(a),
Krzysztof Banasiak^(c)**

^(a) NTNU Norwegian University of Science and Technology,
Trondheim, 7491, Norway, paride.gullo@ntnu.no

^(b) Birla Institute of Technology and Science Pilani,
Rajasthan, 333031, India

^(c) SINTEF Energy Research,
Trondheim, 7491, Norway

ABSTRACT

Due to the enormous carbon footprint of food retail stores the interest in natural working fluids, such as propane (R290) and CO₂ (R744), has recently intensified in the commercial refrigeration sector.

In this theoretical investigation the performance of various technologies employing low-global warming potential (GWP) refrigerants was compared in an average-size supermarket located in different European cities. It was found that a R744 multi-ejector enhanced parallel compression system consumed from 24.6% in Athens (Greece) to 37.1% in Oslo (Norway) less electricity compared to a R404A direct expansion refrigerating solution (baseline). Also, the results obtained suggested that CO₂/R1234ze(E) indirect arrangements perform slightly better than CO₂/R290 indirect units. In particular, the former offered, at best, energy savings by 6.9% (in Athens) over the selected baseline. Finally, it was revealed that the solution outfitted with the multi-ejector block features between 36.8% and 50.3% in heating mode and between 3.1% and 18% in air conditioning (AC) mode lower total power input than separated hydrofluorocarbon (HFC) units over the selected range of outdoor temperatures. It could be concluded that highly efficient as well as climate friendly technologies are readily available for the European food retail industry.

Keywords: Indirect Refrigeration System, Multi-ejector, R290, System Integration, Transcritical CO₂ Refrigeration System

1. INTRODUCTION

About 17% of the worldwide electricity consumption is ascribable to the refrigeration sector, especially due to the fact that supermarkets have spread like wildfire on global perspectives. Such an enormous energy demand leads food retail stores to possess a massive indirect contribution to global warming. In addition, the potent greenhouse gases (e.g. HFC-404A, HCFC-22, HFC-410A) used in commercial refrigeration systems represent a further dramatic threat to the environment. The current global climate change concerns have drawn attention on the need for the phase-down of the aforementioned refrigerants. As a consequence, in an attempt to promote the usage of climate-friendlier technologies for supermarket applications, many regulations have been issued worldwide. The implementation of the Montreal Protocol in 1987 caused the gradual abandon of ozone-depleting working fluids (i.e. CFCs and HCFCs), causing the wide approval of HFCs. However, the predicted catastrophic effects for the environment and human life related to ongoing climate change call for the progressive abandon of these refrigerants. Therefore, the EU introduced the EU F-Gas Regulation 517/2014 (European Commission, 2014) in 2014 aiming at gradually reducing the HFC supply to the European market by 79% from 2015 to 2030 compared to 2009-2012's average levels. As for the food retail industry, the aforementioned regulation set a GWP limit to 2500 for stationary equipment as of 2020 and to 150 for multipack centralized refrigeration systems with rated capacity above 40 kW since 2022. An exception was made for the primary circuit of cascade arrangements, whose GWP limit was fixed equal to 1500. The dramatic impact of HFCs on climate change was recently emphasized by the Kigali Amendment to the Montreal Protocol, resulting in a cut in HFC emissions of well over 70 billion tonnes CO_{2, equivalent} by 2050 on global

perspective. The consequence of the adoption of such legislative acts is that natural refrigerants, such as R290 and particularly R744, are perceived as long-term replacements for today's employed refrigerants in supermarket applications.

Christensen and Bertelsen (2003) reported that the R290/R744 cascade system installed in a small Danish store features energy savings by 5% over an average, conventional and comparable supermarket. The investigation by Kairouani et al. (2015) revealed that a hydrocarbon-based cascade unit presents an enhancement in Coefficient of Performance (COP) up to 70% compared to an all-CO₂ cascade unit over the studied running modes. Liu et al. (2015) proved that such a solution offers a COP_{max} as well as an optimal mass flow ratio with respect to the evaporating temperature, condensing temperature and the temperature difference in the cascade condenser (CC). Ozyurt et al. (2017) shown that the use of an individual constant-geometry ejector in a transcritical R744 supermarket refrigeration system makes such a technology energetically competitive with a R290/R744 cascade solution at outdoor temperature up to 33 °C.

Due to the peculiar properties of CO₂ (i.e. low critical temperature), the performance of basic transcritical R744 systems is dramatically penalized with rise in cooling medium. Therefore, many technologies have been proposed to compensate for these energy inefficiencies (Gullo and Hafner, 2017a, 2017b; Gullo et al., 2017a, 2017b, 2016a, 2016b, 2016c; Hafner et al., 2014; Polzot et al., 2016a; Tsamos et al., 2017). As already widely proved (Gullo and Hafner, 2017a; Gullo et al., 2017a, 2017b; Hafner et al., 2014), the multi ejector concept (Hafner et al., 2014), is the most promising solution for the European food retail industry.

Mota-Babiloni et al. (2015) recommended HFO-1234ze(E) as the working fluid for new refrigerators and R744 cascade arrangements as it possesses a GWP below 1. This refrigerant was employed as the main refrigerant in an English store to substitute a R404A-based unit (UNEP, 2014). Honeywell (2016) predicted an energy saving by 35% compared to comparable supermarkets on the part of the "fully integrated" R1234ze(E)-based indirect system installed in Parma (Italy). The theoretical assessment by Gullo and Cortella (2016) suggested that R1234ze(E)/R744 can be an acceptable alternative for American food retail stores. Also, Purohit et al. (2017) theoretically proved that a R1234ze(E)-based system can outperform "CO₂ only" technologies relying on both dedicated mechanical subcooling and parallel compression at external temperatures above 23 °C.

Despite the great interest drawn by the multi-ejector based technologies, a lack of energy comparison assessments between these and other solutions employing low-GWP refrigerants in supermarket applications can be currently observed. In order to take steps towards this scientific knowledge, the energy consumption of a R744 ejector supported parallel system has been contrasted with that of two R744/R290 indirect arrangements, two R744/R1234ze(E) indirect units and a R404A direct expansion solution (baseline). The evaluation has been implemented by considering an average-size supermarket located in the European climate context. Finally, the performance related to a "fully integrated" R744 booster system relying on multi-ejector module has been compared to that of separate HFC-based units. In fact, although these technologies are supposed to play a key role in the spread of "CO₂ only" supermarket refrigerating solutions across the world, a few investigations on these have been carried out so far.

2. INVESTIGATED SOLUTIONS

2.1 Indirect refrigeration arrangements

The solutions investigated in this paper (Figure 1) are the most promising technologies as regards indirect refrigerating arrangements, as previously highlighted by Gullo and Cortella (2016) and Purohit et al. (2017).

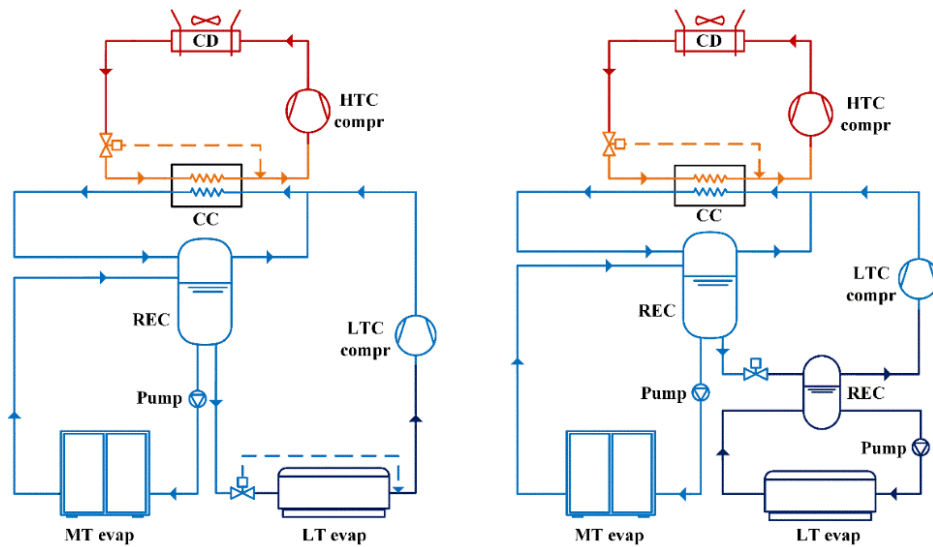
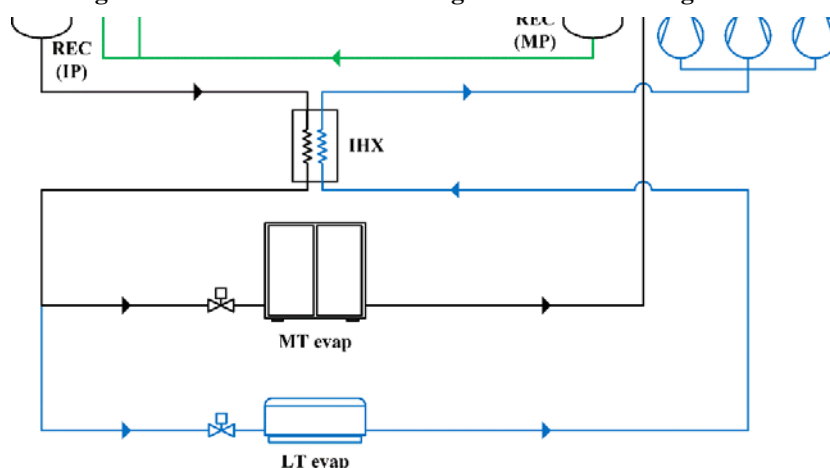

Figure 1: Schematic of the investigated indirect arrangements.



As sketched in Figure 1, these refrigerating systems feature the high temperature (HTC) and two secondary circuits, i.e. medium (MT) and low temperature (LT) units. The HTC, being completely confined in the machinery room, can employ R290 or R1234ze(E). This shares a CC with both MT and LT circuit, which acts as an evaporator for the former and as a condenser for the latter. As for the secondary loop, R744 is used as the secondary fluid to preserve the food in the display counters and cold rooms. As it is possible to notice in Figure 1, MT evaporators in both the depicted solutions operate in flooded mode. With respect to the solution on the right-hand side in Figure 1, this also possesses LT flooded evaporators.

2.2 R744 multi-ejector enhanced parallel compression systems

Unlike the previously considered systems, transcritical refrigeration technologies outfitted with multi-ejector rack (Figure 2) use R744 as the sole working fluid.

As sketched in Figure 2, a multi-ejector block (MEJ) usually possesses 2 liquid (LEJ) and 4-6 vapour ejectors (VEJ). These devices, having different sizes with fixed geometry, are connected in parallel. At least one of VEJ operates permanently and the required capacity is constantly satisfied by changing their combination. A

Figure 2: R744 multi-ejector enhanced parallel compression system with both MT and LT overfed evaporators and implementing heat recovery.

part of the vapor in the medium pressure (MP) receiver is then entrained into VEJ and the total amount of the refrigerant is pre-compressed to the intermediate pressure (IP). As a consequence, a large quantity of R744 is drawn by the auxiliary (or parallel) compressors (AUX) from a higher suction pressure than that of the high-stage (HS) compressors, which experience a substantial unloading with rise in outdoor temperature. This allows achieving prominent energy conservations, which are further incremented thanks to LEJ. These ejectors pump some liquid back to the IP receiver to overfeed the MT evaporators, leading these heat exchangers to have a higher operating temperature than that of dry-expansion evaporators all year round (Gullo et al., 2017a). The use of IHX permits also overfeeding the LT evaporators.

3. INVESTIGATED RUNNING MODES

3.1 Running modes in common

The design refrigeration capacities were assumed equal to 120 kW and 25 kW for the MT and the LT loads (Gullo et al., 2017a), respectively. The deviation from the design running modes due to the variations of the boundary conditions was taken into account with the aid of as shown in Eq. (1) (Gullo et al., 2017a):

$$Load\ fraction = \left(1 - (1 - min)^{\frac{(30-t_{out})}{(30-5)}}\right) \quad (1)$$

in which *min* indicates the minimum fraction of design load (equal to 0.66 for MT and to 0.8 for LT). According to Eq. (1), the cooling capacity ranges from the minimum value reached at $t_{out} \leq 5$ °C and the design value obtained at $t_{out} \geq 30$ °C. As regards the dry-expansion evaporators, MT and LT were respectively taken as -10 °C and -35 °C (Gullo et al., 2017a). Furthermore, the degree of superheating for these heat exchangers was assumed equal to 5 K (Gullo et al., 2017a). Also, a growth in the refrigerant temperature by 5 K in all the suction lines was adopted (Gullo et al., 2017a). The benefits associated with the use of the flooded/overfed evaporators were considered by raising MT and LT respectively by 6 K and 8 K (Gullo et al., 2017a; Gullo and Hafner, 2017a). The consumption related to all the fans was taken as 3% of the heat capacity rejected through the corresponding heat exchanger (Gullo et al., 2017a).

3.2 R404A direct expansion system

The minimum condensing temperature and the condenser approach temperature were respectively assumed equal to 25 °C and 10 K (Gullo et al., 2017a). The compressor performance was evaluated by the correlations proposed by (Gullo et al., 2017a).

3.3 Indirect refrigeration arrangements

The approach temperature of the condenser was respectively selected equal to 10 K and 25 °C (Gullo and Cortella, 2016). The performance of the R1234ze(E) compressors was assessed with the aid of the correlations proposed by Gullo and Cortella (2016), whereas that related to R290 compressors was simulated by using some manufacturer's commercial software. The temperature difference for CC was selected equal to 2 K, whereas the pump had a circulation ratio of 1.5 and 2.5 for respectively MT and LT flooded evaporators (Gullo and Cortella, 2016) and a power input equal to 1% of the total power of the compressors (Gullo and Cortella, 2016). It is crucial to highlight that, in order to make a fair comparison, the same values of MT and LT for the overfed and flooded evaporators were adopted. With respect to the temperature difference for the cascade condenser, this value is usually above 2 K (Gullo and Cortella, 2016).

3.4 R744 multi-ejector enhanced parallel compression systems

The performance of the R744 ejector supported parallel systems was optimized as a function of the pressure lift, i.e. the difference in pressure between the two liquid receivers. This was ranged from 4 bar to 15 bar (Gullo et al., 2017a). Furthermore, the correlation proposed by Gullo et al. (2017a) were used for simulating the multi-ejector pack. The effectiveness of IHX was taken as 0.5 (Gullo et al., 2017a), while AUX were assumed to be substituted with a vapor by-pass valve (VB) in subcritical running modes. The performance of all the compressors was simulated by employing the correlations by Gullo et al. (2017a). Also, the occurrence of the subcritical, transition and transcritical operating conditions were evaluated to occur in the same way as suggested by Gullo et al. (2017a).

3.5 Investigated heating and AC modes

The total COPs of a multi-ejector based technology with both MT and LT overfed evaporators were contrasted with those of separated HFC-based units (i.e. R404A direct expansion system for refrigeration loads and R410A reversible heat pump equipment for space heating and AC reclaim) in both heating and AC mode. The total COP refers to the ratio of the sum of refrigeration and heating/AC loads to the total power input.

As for the heating mode, the heat recovery in favour of heating unit and DHW production was considered to occur in the de-superheater (DES) in the investigated transcritical R744 solution and the gas cooler (GC) was supposed to be by-passed via a 3-way valve (Figure 2). Being an appealing technique (Sawalha, 2013; Reinholdt and Madsen, 2010; Polzot et al., 2016b), the heat recapture implementation has become in transcritical R744 supermarket refrigerating systems.

Furthermore, the return temperature was set to 30 °C, while the design value of the heating load was chosen equal to 140 kW which was kept constant as low external temperatures were considered. As for the R410A unit, the condensing temperature and the evaporator temperature difference were taken as 37 °C and 10 K, respectively.

With respect to the AC mode, the AC demand was assumed to be provided with the aid of a further overfed heat exchanger operating at 5 °C for the selected R744 system. As regards the R410A unit, the evaporating temperature and the condenser temperature difference were taken as 3 °C and 10 K, respectively. The R410A compressors were evaluated by employing the correlations proposed by Gullo and Hafner (2017a) in both modes. The AC load was supposed to be linearly depending on the outdoor temperature for a design value of 120 kW (Gullo and Hafner, 2017a).

4. OUTDOOR TEMPERATURES

Figure 4 depicts the external temperature over the year for the selected five European cities, presenting cold (i.e. Oslo), mild (i.e. Frankfurt and Milan) and warm (i.e. Valencia, Athens) climates.

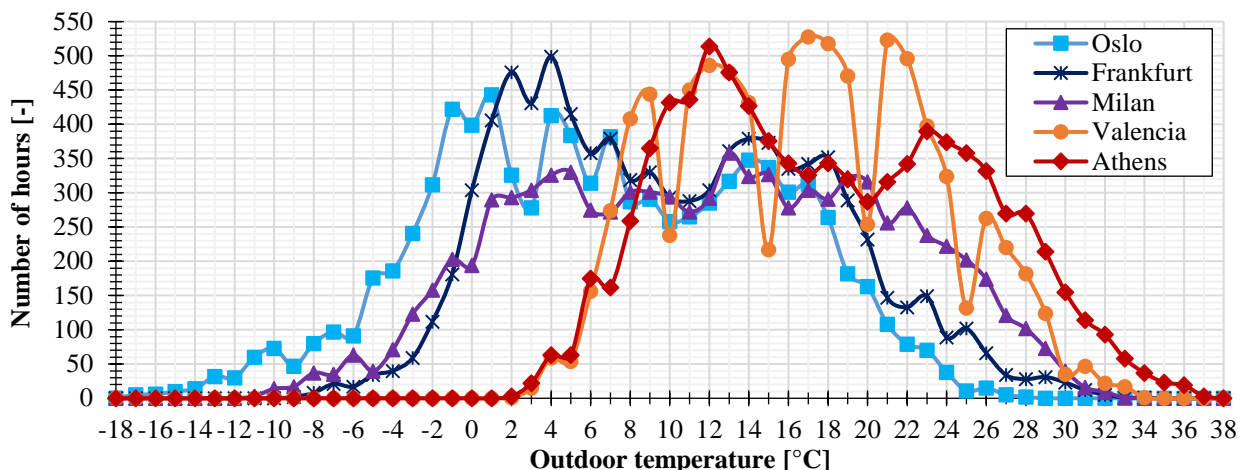

Figure 3: Numbers of hours per year at different outdoor temperatures in the selected locations (EnergyPlus).

5. RESULTS

5.1 Annual energy consumption

The annual energy consumption of the investigated refrigerating systems is shown in Figure 4 for all the selected locations. The heating and AC needs were assumed to be separately provided in this subsection.

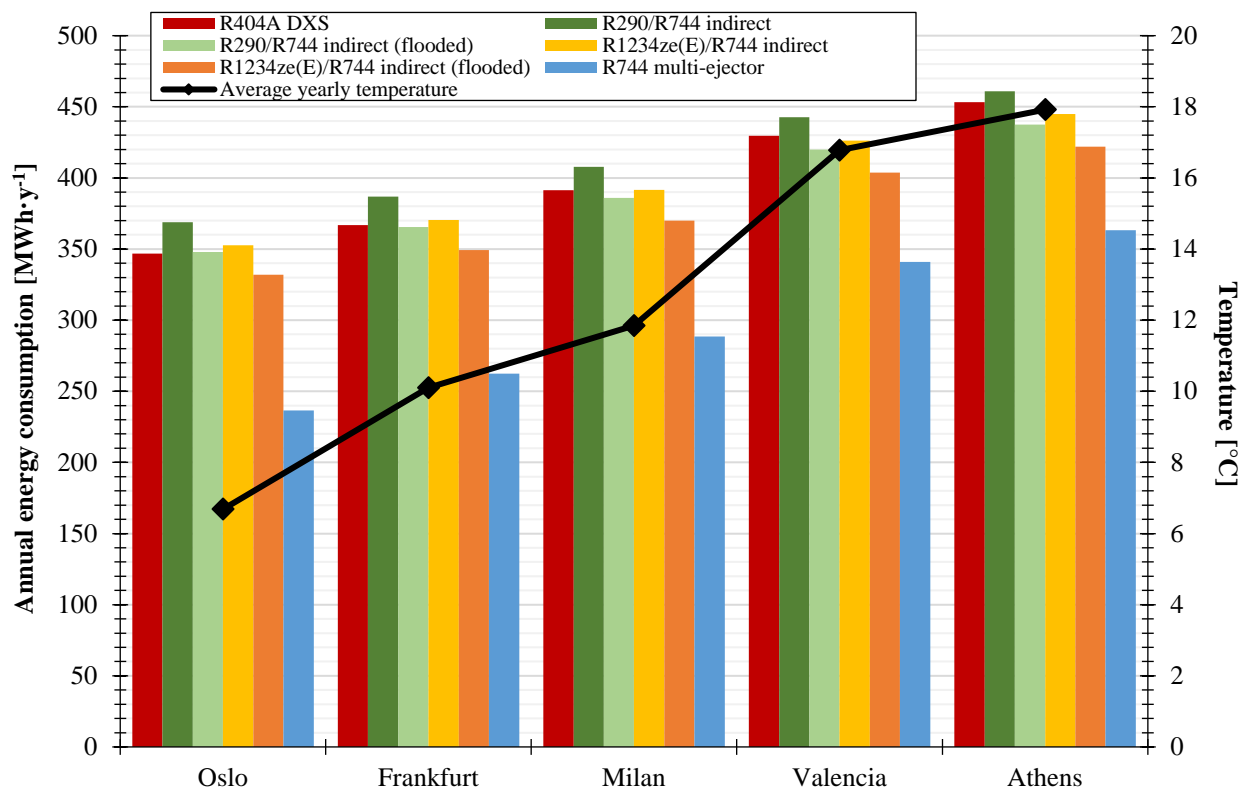

Figure 4: Annual energy consumption of all the investigated solutions in all the selected cities.

In all the chosen cities, the investigated transcritical R744 technologies can significantly outperform all the other selected solutions, even in warm climate contexts. Also, this study revealed that R1234ze(E)/R744-based systems are preferable technologies from the energy viewpoint to R290/R744-based arrangements in the European commercial refrigeration sector. In Oslo (i.e. cold climate), the adoption of the multi-ejector concept led to energy conservations up to 37.1% over the chosen baseline, whereas it was found that indirect arrangements are not suitable alternatives in these locations. In Milan (i.e. mild location) the transcritical R744 system consumed 31.2% less electricity than the baseline, whereas R1234ze(E)/R744-based system with both MT and LT flooded evaporators is the only energetically acceptable replacement among the investigated indirect arrangements. In Athens (i.e. warm city) the R744 ejector supported refrigeration system presented an energy conservation by 24.6% compared to the baseline, whereas indirect arrangements at best reduced the energy consumption by 6.9%.

5.2 Heating mode

In Figure 5 the outcomes associated with the heating mode are compared in terms of total power input for the investigated solutions. In spite of the high design value of the heating need, the CO₂ refrigerating unit outfitted with multi-ejector module featured from 36.8% to 50.3% better performance than separated HFC-based systems at external temperatures ranging from -10 °C up to 5 °C. It was crucial to notice that the total power input related to the selected R744 multi-ejector enhanced parallel compression system was constant, since the temperature of the cooling medium corresponded with that of the return water (i.e. 30 °C) in all the evaluated operating conditions and the gas cooler was considered to be by-passed.

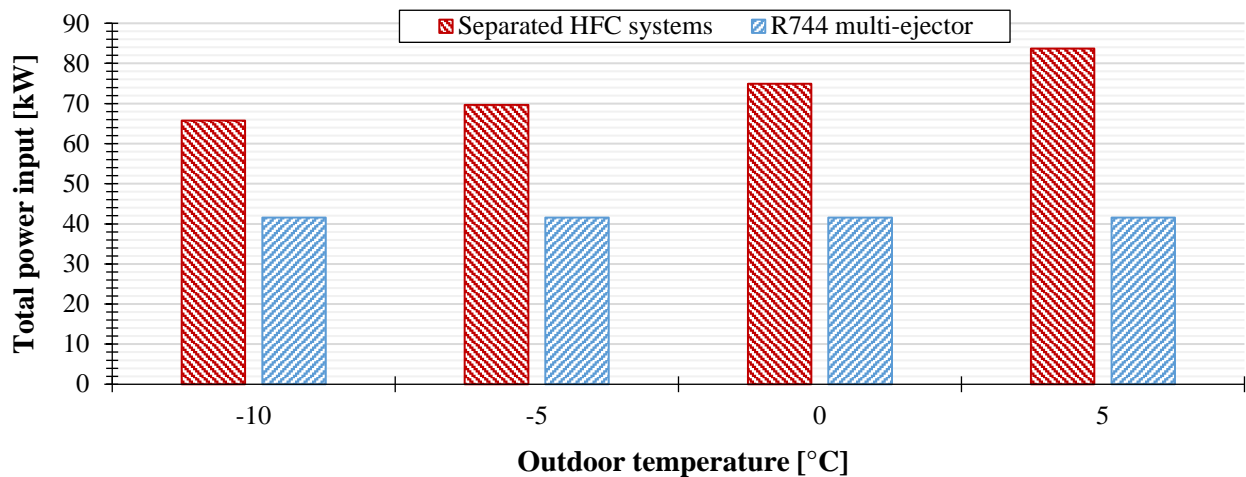

Figure 5: Total power input of the investigated systems in heating mode at different outdoor temperatures.

5.3 AC mode

As shown in Figure 6, the selected transcritical R744 unit presented from 3.1% up to 18% lower total power input than separated HFC-based units over the investigated range of outdoor temperatures. Therefore, it was possible to claim that the multi-ejector based technologies are more energy beneficial than the today's employed systems even with massive AC demands taking place in warm areas.

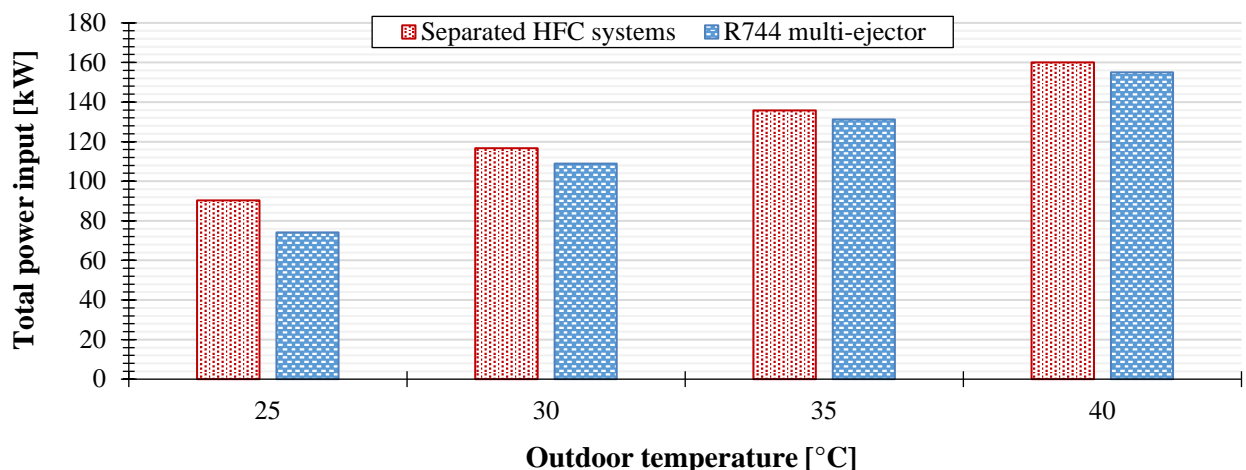

Figure 6: Total power input of the investigated systems in AC mode at different outdoor temperatures.

6. CONCLUSIONS AND FUTURE WORK

The theoretical outcomes obtained bring to light that the state-of-the-art transcritical R744 refrigerating technologies are the most eco-friendlier alternatives to the currently employed solutions in the European food retail industry. In particular, the R744 ejector supported parallel solution features energy savings between 24.6% (in Athens) and 37.1% (in Oslo) compared to a R404A direct expansion refrigeration unit in an average-size European food retail store. At best, indirect arrangements offer energy conservations ranging from 5.4% (in Milan) to 6.9% (in Athens) in mild and warm locations, whereas such technologies are not suitable alternatives for cold climates. Also, it was found that R1234ze(E)/R744 indirect refrigeration arrangements can slightly outperform R290/R744 indirect refrigeration arrangements in the European climate context. In addition, this investigation shows that the selected “fully integrated” R744 system equipped with multi-ejector module presents from 36.8% to 50.3% in heating mode and from 3.1% up to 18% in AC mode lower total power input than separated HFC-based technologies over the investigated range of external temperatures. It is important to highlight that these assessments have been based on large heating and AC units.

It is worth remarking that “all-in-one” R744 multi-ejector enhanced parallel compression systems are already being commercialized with great results even in high ambient temperature countries. On the other hand, future

experimental investigations on the assessment of the energy and economic benefits related to the use of two different multi-ejector modules, direct heating and cooling fan coils and air curtains and the principle of pivoting are still needed. Also, further experimental evaluations associated with integrated R744 multi-ejector enhanced parallel compression technologies in hot climate contexts (e.g. India) should also be carried out. Finally, it is also important to emphasize that the usage of HFOs has to be strongly discouraged in the food retail industry. In fact, firstly, HFO-based indirect arrangements show poorer performance in relation to “CO₂ only” systems in any European climate condition, as well as R1234ze(E) is flammable and enormously costly. Also, Greenpeace (2016) reported that HFOs are basically HFCs with a different name and HFO blends have a high GWP. Furthermore, both the production and the decomposition into the atmosphere of HFOs involve the creation of toxic by-products.

NOMENCLATURE

<i>AC</i>	air conditioning	<i>CFC</i>	chlorofluorocarbon
<i>COP</i>	coefficient of performance (-)	<i>GWP</i>	global warming potential ($\text{kg}_{\text{CO}_2,\text{equ}} \cdot \text{kg}_{\text{refrigerant}}^{-1}$)
<i>HCFC</i>	hydrochlorofluorocarbon	<i>HFC</i>	hydrofluorocarbon
<i>HFO</i>	hydrofluoroolefin	<i>HTC</i>	high temperature circuit
<i>LT</i>	low temperature (°C)	<i>MT</i>	medium temperature (°C)
<i>out</i>	outdoor	<i>t</i>	temperature (°C)

REFERENCES

- Christensen, K.G., Bertelsen, P., 2004. Refrigeration systems in supermarkets with propane and CO₂ – energy consumption and economy. – Available at: <http://www.r744.com/files/pdf_319.pdf> [accessed 01.12.2017].
- EnergyPlus. EnergyPlus: Weather Data Sources – Available at: <<https://energyplus.net/weather>> [accessed 01.12.2017].
- European Commission, 2014. Regulation (EU) No 517/2014 of the European Parliament and of the Council of 16th April 2014 on fluorinated greenhouse gases and repealing Regulation (EC) No 842/2006.
- Greenpeace, 2016. HFOs: the new generation of F-gases. Greenpeace Position Paper. – Available at: <<http://www.greenpeace.org/international/en/publications/reports/HFOs/>> [accessed 01.12.2017].
- Gullo, P., Hafner, A., 2017b. Thermodynamic Performance Assessment of a CO₂ Supermarket Refrigeration System with Auxiliary Compression Economization by using Advanced Exergy Analysis. *Int. J. Thermodyn.* 20(4), 220-227.
- Gullo, P., Hafner, A., 2017a. Comparative assessment of supermarket refrigeration systems using ultra low-GWP refrigerants – Case study of selected American cities. *Proceedings of the 30th International Conference on Efficiency, Cost, Optimisation, Simulation and Environmental Impact of Energy Systems*, San Diego, USA.
- Gullo P., Tsamos K., Hafner A., Ge Y., Tassou S., 2017b. State-of-the-art technologies for R744 refrigeration systems – A theoretical assessment of energy advantages for European food retail industry. *Energy Procedia* 123, 46-53.
- Gullo P., Hafner A., Cortella G., 2017a. Multi-ejector R744 booster refrigerating plant and air conditioning system integration – A theoretical evaluation of energy benefits for supermarket applications. *Int. J. Refrigeration* 75, 164-176.
- Gullo, P., Cortella, G., 2016. Theoretical evaluation of supermarket refrigeration systems using R1234ze(E) as an alternative to high-global warming potential refrigerants. *Sci. Technol. Built En.* 22(8), 1145-1155.
- Gullo, P., Cortella, G., Minetto, S., Polzot, A., 2016c. Overfed evaporators and parallel compression in commercial R744 booster refrigeration systems – An Assessment of energy benefits. *Proceedings of the 12th IIR Gustav Lorentzen Natural Working Fluids Conference*, Edinburgh, UK, IIF/IIR, ID: 1039.
- Gullo, P., Elmegaard, B., Cortella, G., 2016b. Advanced exergy analysis of a R744 booster refrigeration system with parallel compression. *Energy* 107, 562-571.
- Gullo P., Elmegaard B., Cortella G., 2016a. Energy and environmental performance assessment of R744 booster supermarket refrigeration systems operating in warm climates. *Int. J. Refrigeration* 64, 61-79.

- Hafner A., Försterling S., Banasiak K., 2014. Multi-ejector concept for R-744 supermarket refrigeration. *Int. J. Refrigeration* 43, 1-13.
- Honeywell, 2016. Supermarket innovation: MINIMUM COSTS, CARBON (GWP<1) AND ENERGY (-35% EXPECTED) FOR INTEGRATED HEATING & COOLING & A/C. – Available at: <<https://www.honeywell-refrigerants.com/europe/wp-content/uploads/2016/02/FPR-014-2016-01-EN-Case-Study-Solstice-ZE-U2-LR.pdf>> [accessed 01.12.2017].
- Kairouani, L., Jemni, N., Nehdi, E., 2015. Energetic analysis of CO₂/Propane and CO₂/Propylene cascade refrigeration system. Proceedings of the 6th IIR Ammonia and CO₂ Refrigeration Technologies Conference, Ohrid, Macedonia, IIF/IIR.
- Liu, S., Chen, Y., Ning, J., 2015. Optimization analysis on R290/CO₂ cascade refrigeration system. Proceedings of the 24th IIR International Congress of Refrigeration, Yokohama, Japan, IIF/IIR, ID: 390.
- Mota-Babiloni, A., Navarro-Esbri, J., Moles, F., Barragan-Cervera, A., Peris, B., Verdu, G., 2015. A review of refrigerant R1234ze(E) recent investigations. *Appl. Therm. Eng.* 95, 211-222.
- Ozyurt, A., Sinar, U., Yilmaz, D., Yilmaz, B., 2017. The performance evaluation of CO₂ transcritical booster and R290/R744 cascade refrigeration systems for different cities in Turkey. Proceedings of the 7th IIR Conference on Ammonia and CO₂ Refrigeration Technologies, Ohrid, Macedonia, IIF/IIR.
- Polzot, A., Gullo, P., D'Agaro, P., Cortella, G., 2016b. Performance evaluation of a R744 booster system for supermarket refrigeration, heating and DHW. Proceedings of the 12th IIR Gustav Lorentzen Natural Working Fluids Conference, Edinburgh, UK, IIF/IIR.
- Polzot A., D'Agaro P., Gullo P., Cortella G., 2016a. Modelling commercial refrigeration systems coupled with water storage to improve energy efficiency and perform heat recovery. *Int. J. Refrigeration* 69, 313-323.
- Purohit, N., Gullo, P., Dasgupta, M.S., 2017. Comparative assessment of low-GWP based refrigerating plants operating in hot climates. *Energy Procedia* 109, 138-145.
- Reinholdt, L., Madsen, C., 2010. Heat recovery on CO₂ systems in supermarkets. In: Proceedings of the 9th IIR Gustav Lorentzen Conference on Natural Working Fluids, Sydney, Australia, IIF/IIR, ID: 143.
- Sawalha, S., 2013. Investigation of heat recovery in CO₂ trans-critical solution for supermarket refrigeration. *Int. J. Refrigeration* 36(1), 145-156.
- Tsamos, K. M., Gullo, P., Ge, Y. T., IDewa Santosa, Tassou, S. A., Hafner, A., 2017. Performance investigation of the CO₂ gas cooler designs and its integration with the refrigeration system. *Energy Procedia* 123, 265-272.
- UNEP, 2014. Low-GWP Alternatives in Commercial Refrigeration: Propane, CO₂ and HFO Case Studies. – Available at: <http://www.unep.fr/ozonaction/information/mmcfiles/7686-e-Low_GWP_Alternatives_in_Commercial_Refrigeration.pdf> [accessed 01.12.2017].