

Operational Hydropower Simulation in Cascaded River Systems for Intraday Re-planning

Hans Ivar Skjelbred

Jiehong Kong

Department of Energy Systems

SINTEF Energy Research

Trondheim, Norway

HansIvar.Skjelbred@sintef.no

Abstract—In this paper, we introduce an operational implementation of a hydropower simulator for cascaded river systems. It is presently used for decision support in the intraday re-planning by the largest hydropower producer in Norway. It simulates the hydro production at a highly detailed level with very fine time resolution. The outcome obtained in one time period will be immediately used to facilitate the calculation at the next time period. The continuous updating of the information within short intervals not only advances the convergence but also allows the simulator to capture nonlinear dynamics and state-dependency of the complex hydrological systems. Case studies illustrate the basic properties of the simulation algorithm and the role as a decision support tool in intraday re-planning. Numerical results demonstrate the superiority of the simulation model over the re-optimization, both in terms of precision and calculation time, when verifying whether a manual change in the dispatch plan can avoid spillage.

Index Terms—Hydroelectric power generation, intraday operation, short-term hydro scheduling, simulation.

NOMENCLATURE

Sets and Indices:

T^{SIM}	Set of time periods in simulation, index $t \in T^{SIM}$.
T^{OPT}	Set of time periods in optimization, index $\theta \in T^{OPT}$.
K	Set of reservoirs, index $k \in K$.
S	Set of plants, index $s \in S$.
N_s	Set of penstocks in plant s , index $n \in N_s$.
I_s	Set of units in plant s , index $i \in I_s$.
$I_{n,s}$	Set of units that connect to penstock n in plant s , index $i \in I_{n,s}$.

Note that the cascaded objects in the watercourse are indicated in sequence. Reservoir k always refers to the direct upstream reservoir of plant s and reservoir $k + 1$ refers to the direct downstream reservoir of plant s , unless otherwise stated.

Parameters:

δ^{SIM}	Time resolution in simulation (second, s).
δ^{OPT}	Time resolution in optimization (s).
$V_{k,0}^{INIT}$	Initial water storage of reservoir k (cubic meter, m^3).

$Q_{k,t}^{NI}$	Forecast inflow in reservoir k in period t (m^3/s).
$Q_{k,t}^{BYPASS}$	Water released via bypass gate of reservoir k in period t (m^3/s).
L_s	Outlet line of plant s (meter, m).
G	Conversion constant taking into account the gravity acceleration, water density and makes the appropriate unit conversions from (m) and (m^3/s) to (Megawatt, MW), default setting is $10^{-3} \cdot 9.81$.
$\alpha_{n,s}$	Loss factor of penstock n in plant s (s^2/m^5).
$P_{i,s,t}$	Production schedule for unit i in plant s in period t (MW).

Variables:

$v_{k,t}$	Water storage of reservoir k at the end of period t (m^3).
$h_{s,t}^{GROSS}$	Gross head of plant s in period t (m).
$h_{i,s,t}^{NET}$	Net head of unit i in plant s in period t (m).
$q_{k,t}^{TOTAL}$	Total regulated water release of reservoir k in period t (m^3/s).
$q_{i,s,t}$	Water discharge of unit i in plant s in period t (m^3/s).

One-dimensional Functions:

$\eta_i^{GEN}(P_{i,s,t})$	Generator efficiency of unit i as a function of the production of the unit (%).
$l_{k,t-1}(v_{k,t-1})$	Water level of reservoir k at the beginning of period t as a function of the water storage of the reservoir (m).
$q_{k,t}^{OVER}(l_{k,t-1}(v_{k,t-1}))$	Unregulated water release (overflow) of reservoir k in period t as a function of the water level of the reservoir (m^3/s).

Two-dimensional Functions:

$\eta_i^{TURB}(h_{i,s,t}^{NET}, q_{i,s,t})$	Turbine efficiency of unit i as a function of the net head and water discharge of the unit (%).
---	---

$$\Delta h_{s,t}^{INTAKE}(l_{k,t-1}(v_{k,t-1}), q_{k,t}^{TOTAL})$$

Intake head loss of plant s in period t as a function of the water level of upstream reservoir k and the total regulated water release of the reservoir (m).

$$\Delta h_{s,t}^{TAIL}(l_{k+1,t-1}(v_{k+1,t-1}), q_{k,t}^{TOTAL})$$

Tailrace head loss of plant s in period t as a function of the water level of downstream reservoir $k + 1$ and the total regulated water release of the upstream reservoir k (m).

Note that all the one- and two-dimensional relationships are determined empirically and formulated as piecewise-linear functions. Examples can be found in Figure 2 and . Linear interpolation is used to interpolate between points for intermediate values.

I. INTRODUCTION

In short-term hydro scheduling (STHS), the optimization models are crucial decision support tools used in daily operations. The large number of reservoirs and hydropower plants in a cascaded river system significantly increases the complexity of these models (Figure 1). Considering the trade-off between the accurate representation of the hydro production function (HPF) and low computational time, one approach is to simplify or even leave out the nonlinearity and state-dependency in the formal optimization methods, e.g. assuming a constant unit efficiency without head effect [1]. The alternative is to employ different solution methodologies or heuristics to handle the problems [2]. [3] presented a detailed review of different approaches to model the HPF. [4] summarized the algorithms and solving strategies that have been proposed in the literature.

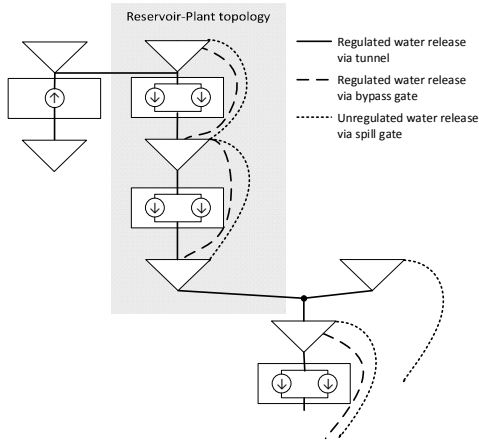

Figure 1. A typical cascaded river system in Norwegian watercourses

Since a simulation model can directly address nonlinear and state-dependent constraints, it is usually used to verify whether the optimal schedules determined by the optimization model are feasible for the actual physical system.

In this paper, we present an operational implementation of a hydropower simulator for cascaded river systems. It is originally designed for the validation of the results from an optimization model, the short-term hydro optimization program (SHOP) [5]. Therefore, it inherits the same modelling details and identical representation of hydraulic systems as SHOP. We

herein refer to the simulation model as SHOP-SIM in the rest of the paper.

In practice, SHOP-SIM is used for decision support in the intraday re-planning by the largest hydropower producer in Norway. Hydropower producers participating in the deregulated electricity markets must always have a feasible production plan for their generating units. The initial plan is typically found by an optimization tool some period ahead of delivery. Unforeseen events, such as sudden changes in the forecasted inflow or equipment malfunctions, can still occur before the hour of actual dispatch. Without enough time for a full re-optimization, a manual change in the dispatch plan has to be made to save water from spillage or to avoid generation imbalances. In this context, a simulation model that responds rapidly is essential to examine whether the modification is justified or not.

The main contribution of this paper is to present how SHOP-SIM simulates the hydro production at a highly detailed level with very fine time resolution. The outcome obtained in previous time period will be immediately used to facilitate the calculation at current time period. The continuous updating of the information within short time intervals not only advances the convergence but also allows the simulator to capture nonlinear dynamics and state-dependency of the complex hydrological system. Numerical results based on data from real-world cascaded watercourse demonstrate the effectiveness and feasibility of the proposed method. To simulate a watercourse consisting of 7 hydropower plants and 9 reservoirs for one week with a time resolution of 10 seconds, the whole simulation procedure takes less than 0.1 seconds.

In the following, a brief description of the hydrological balance in the reservoirs and the power generation in the plants is provided in Section II. The simulation methodology is presented in Section III. The test cases and numerical results are reported in Section IV. Finally, Section V concludes.

II. PROBLEM DESCRIPTION

The simulation model is developed to represent all the hydraulic objects and their coherence in the cascaded river system. In this paper, we focus on the typical reservoir-plant cascade scheme, i.e. the topology marked in gray in Figure 1. Flow processed by pumps, or going through connection gates between two reservoirs or junctions, are implemented in the simulator, but left out of this paper for brevity.

A. Water Balance in the Reservoirs

$$v_{k,0} = V_{k,0}^{INIT}, \forall k \in K. \quad (1)$$

$$v_{k,t} = v_{k,t-1} + \delta^{SIM} \cdot \left(Q_{k,t}^{NI} + q_{k-1,t}^{TOTAL} + q_{k-1,t}^{OVER}(l_{k-1,t-1}(v_{k-1,t-1})) - q_{k,t}^{TOTAL} - q_{k,t}^{OVER}(l_{k,t-1}(v_{k,t-1})) \right), \quad (2)$$

$$k \in K, t \in T^{SIM}.$$

$$q_{k,t}^{TOTAL} = \sum_{i \in I_s} q_{i,s,t} + Q_{k,t}^{BYPASS}, s \in S, k \in K, t \in T^{SIM}. \quad (3)$$

In (1) and (2), we model the hydrological balance of reservoir k associated with plant s . The water storage of reservoir k

at the end of period t is the storage at the beginning of the period plus the volume of inflow minus outflow in period t . The volume of flow is decided by the length of time period (i.e. time resolution) in simulation. The total inflow includes the forecasted inflow and the water discharged from the upstream reservoir or hydraulic objects. The total outflow consists of regulated and unregulated water release. Note that, for the sake of clarity, the water travel time between reservoirs is not included in this paper, but modeled in SHOP-SIM.

The regulated water release refers to the flow going through plants or bypass gates, as expressed in (3). In literature, the flow that can be controlled precisely by adjusting gate openings is also called the spillage in the plant. This flow can be regulated to balance the minimum outflow constraints and transmission capacity limits [3]. By contrast, the unregulated water release is associated with the uncontrollable flow, which occurs when a reservoir runs full and the water spills over the top of the dam or goes through the spill gate. The overflow description is represented by a one-dimensional piecewise-linear function of the water level of the reservoir, as can be seen in Figure 2. It starts at the highest regulation level with the overflow of 0.

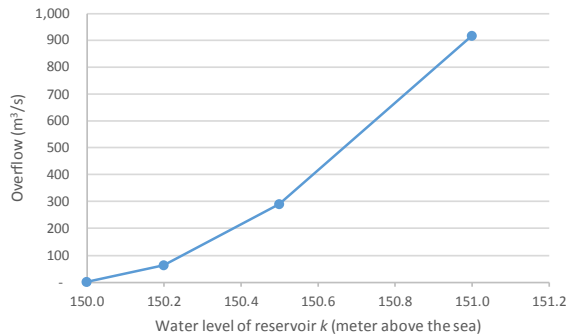

Figure 2. Example of one-dimensional piecewise-linear overflow description

B. Relationship between Water Storage and Plant Head

$$h_{s,t}^{GROSS} = l_{k,t-1}(v_{k,t-1}) - \max_{s \in S, t \in T^{SIM}} [l_{k+1,t-1}(v_{k+1,t-1}), L_s], \quad (4)$$

$$h_{i,s,t}^{NET} = h_{s,t}^{GROSS} - \alpha_{n,s} \cdot \left(\sum_{i \in I_{n,s}} q_{i,s,t} \right)^2 - \Delta h_{s,t}^{INTAKE}(l_{k,t-1}(v_{k,t-1}), q_{k,t}^{TOTAL}) - \Delta h_{s,t}^{TAIL}(l_{k+1,t-1}(v_{k+1,t-1}), q_{k,t}^{TOTAL}), \quad (5)$$

$i \in I_{n,s}, n \in N_s, s \in S, t \in T^{SIM}.$

As expressed in (4), based on the storage of upstream reservoir $v_{k,t-1}$ and the storage of downstream reservoir $v_{k+1,t-1}$ (if water level of downstream reservoir $k+1$ is higher than the outlet line of the plant), the gross plant head can be calculated in a straightforward way. It is worth mentioning that instead of using averages of stored water in certain time period to determine the water level [6, 7], we utilize the value at the beginning of period t . Since the time resolution in simulation is small enough (usually less than 10 seconds), this assumption is appropriate for the presented method.

The net head for one unit is influenced by three types of loss: 1) the penstock head loss is related to the friction of water on the penstock wall and can be represented as a quadratic function of the total flow going through the penstock [8]; 2) the intake

head loss is associated with the water level of upstream reservoir and the velocity of the water flow passing through the plant; and 3) the tailrace elevation can vary considerably as a consequence of the total water discharge of the plant, and therefore, tailrace loss takes place. If hydraulic cohesive relationship exists, the tailrace elevation is also influenced by the water level of immediate downstream reservoir [9, 10]. Because of the nature shape of a reservoir, given a water discharge rate, the lower water level of the downstream reservoir is, the quicker the water level will increase and hence the larger the tailrace loss will be. shows the two-dimensional relationship between tailrace head loss of the plant, regulated water release from upstream reservoir and the water level of downstream reservoir. Therefore, the net head for a unit involves not only the flow through the unit but also the total flow of all the units that are connected to the same penstock as the unit is, and the total discharge through the plant.

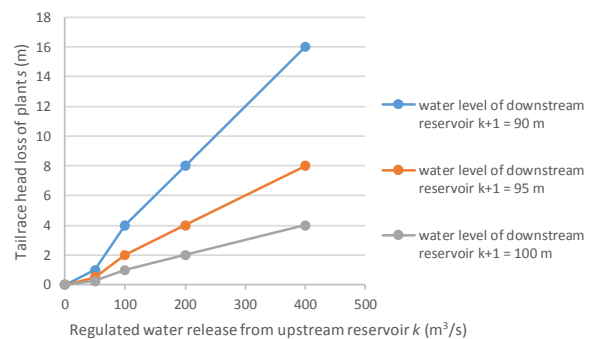

Figure 3. Example of two-dimensional piecewise-linear tailrace head loss

C. Hydro Production Function

$$P_{i,s,t} = G \cdot \eta_i^{GEN}(P_{i,s,t}) \cdot \eta_i^{TURB}(h_{i,s,t}^{NET}, q_{i,s,t}) \cdot h_{i,s,t}^{NET} \cdot q_{i,s,t}, \quad (6)$$

$i \in I_s, s \in S, t \in T^{SIM}.$

For a specific unit, the power generation depends on the net head and the water discharge of that unit. It also relies on the generator efficiency and head-dependent turbine efficiency.

Constraints (1)–(6) constitute the HPF. A strategy that can balance an accurate representation and an acceptable computational burden is always the focus for large-scale STHS problems. Nonconcave regions of the HPF are normally approximated by using a special technique to make the description convex [3]. Nonlinearity is handled by piecewise-linear approximation [7]. Currently, SHOP formulates the problem as a mixed integer linear programming (MILP) model and employs an iterative approach to refine the nonlinearity and state-dependency of head variation and hydraulic losses. SHOP-SIM verifies the optimized result of SHOP by direct representation of the nonlinear dynamics with very fine time resolution. Given the unit production and the water release via the bypass gates from optimization, the corresponding water transportation in the watercourses can be validated.

III. SIMULATION METHODOLOGY

Due to the problem size and hydrological complexity, time resolution in optimization for STHS is usually hourly and planning horizon is 1 – 14 days [11]. By contrast, time resolution in simulation can be as fine as seconds. Since SHOP-SIM is used

as a tool to verify the optimized result, the mapping between time periods in optimization and periods in simulation should be clearly defined in order to adequately transfer and compare data. We hence introduce

$\Theta(t)$ Time period in optimization as a function of time period t in simulation.

TABLE I gives an example of one-week planning horizon. If the time resolution in optimization is 15 minutes (i.e. 900 seconds) and the time resolution in simulation is 10 seconds, the total time periods for optimization will be 672 and for simulation be 60,480. Then every 90 time periods in simulation can be mapped to the same period in optimization. The unit production and the regulated water release via bypass gates are the results from optimization and are the input data to simulation. Therefore, as long as $\Theta(t) = \theta$, the values $P_{i,s,t}$ and $Q_{k,t}^{BYPASS}$ at all the periods t in simulation are the same as the value $P_{i,s,\theta}$ and $Q_{k,\theta}^{BYPASS}$ at period θ in optimization.

TABLE I EXAMPLE OF MAPPING BETWEEN TIME PERIODS IN SIMULATION AND TIME PERIODS IN OPTIMIZATION

Time period t in simulation $\delta^{SIM} = 10$ seconds $T^{SIM} = 60,480$	Mapping between periods in simulation and optimization $\Theta(t) = \theta$	Time period θ in optimization $\delta^{OPT} = 900$ seconds $T^{OPT} = 672$
1	$\Theta(1) = 1$	1
2	$\Theta(2) = 1$	
...	...	
90	$\Theta(90) = 1$	2
91	$\Theta(91) = 2$	
...	...	
180	$\Theta(180) = 2$	672
...	...	
60,391	$\Theta(60,391) = 672$	
...	...	
60,480	$\Theta(60,480) = 672$	

The simulation process is summarized as follows:

Step 1: Initialize the water storage of each reservoir by (1).

Step 2: Determine the overflow if spillage of reservoir occurs.

Step 3: Determine the gross head of each plant by (4).

Step 4: Estimate the water discharge of each unit by (7).

$$\tilde{q}_{i,s,t} = \frac{P_{i,s,t}}{G \cdot \tilde{\eta} \cdot h_{s,t}^{GROSS}}, i \in I_s, s \in S. \quad (7)$$

where

$\tilde{q}_{i,s,t}$ Estimated water discharge of unit i in plant s in period t (m^3/s).

$\tilde{\eta}$ Estimated turbine-generator efficiency, default setting is 90%.

Step 5: Determine the net head of each unit by (9).

After estimating all the water discharge of the units, we can update the total regulated water discharge in (8) and further calculate the net head of the unit in (9).

$$\tilde{q}_{k,t}^{TOTAL} = \sum_{i \in I_s} \tilde{q}_{i,s,t} + Q_{k,t}^{BYPASS}, s \in S. \quad (8)$$

where

$\tilde{q}_{k,t}^{TOTAL}$ Estimated total regulated water release of reservoir k in period t (m^3/s).

$$h_{i,s,t}^{NET} = h_{s,t}^{GROSS} - \alpha_{n,s} \cdot \left(\sum_{i \in I_{n,s}} \tilde{q}_{i,s,t} \right)^2 - \Delta h_{s,t}^{INTAKE}(l_{k,t-1}(v_{k,t-1}), \tilde{q}_{k,t}^{TOTAL}) - \Delta h_{s,t}^{TAIL}(l_{k+1,t-1}(v_{k+1,t-1}), \tilde{q}_{k,t}^{TOTAL}), i \in I_{n,s}, n \in N_s, s \in S. \quad (9)$$

Step 6: Determine the water discharge for each unit by (10).

Given $h_{i,s,t}^{NET}$ and $\tilde{q}_{i,s,t}$, we can finally define the water discharge of the unit as

$$q_{i,s,t} = \frac{P_{i,s,t}}{G \cdot \eta_i^{GEN}(P_{i,s,t}) \cdot \eta_i^{TURB}(h_{i,s,t}^{NET}, \tilde{q}_{i,s,t}) \cdot h_{i,s,t}^{NET}}, i \in I_s, s \in S. \quad (10)$$

Step 7: Determine the water storage of reservoirs at the end of period t by (2).

Step 8: Move to the next simulation time period $t + 1$ and check whether it is the last time period in simulation:

- If yes, the simulation process ends;
- If not, repeat *Step 2* and *Step 3*. Then check whether the mapping of the new simulation time period $\Theta(t + 1)$ is equal to the previous optimization time period θ :
 - If yes, it implies that the production schedule for all the units is the same as the ones at pervious time period. Then we return to *Step 5* and use the water discharge of the units from previous simulation time period to calculate the net head at current period;
 - If not, we move to the next optimization time period $\theta + 1$. Return to *Step 4* and re-estimate the water discharge of each unit.

The whole procedure is illustrated in Figure 4. As can be seen, at each time period simulation occurs in parallel for all the facilities and then the cascade effects along the river are updated by the water discharge going through reservoirs and plants. In addition, the initial estimation of water discharge for each unit at the beginning of the time period θ in optimization (*Step 4*) is not precise, leading to the rough estimation of the net head in (9) and unit turbine efficiency in (10). However, these values will quickly converge by the continuous updating at each period t in simulation (*Step 8*).

IV. NUMERICAL ILLUSTRATION

We first use an illustrative case to reveal the basic properties of the simulation methodology. Then a realistic case with a cascade of reservoirs and hydropower plants along a river is employed to indicate how the simulator works as a decision support tool in intraday re-planning to avoid unexpected spillage. Numerical results demonstrate the superiority of the simulation model over the full re-optimization or re-optimization with manual changes both in terms of precision and calculation time.

The planning horizon in all the tests is one week. The time resolution in optimization (SHOP) is 15 minutes and resolution in simulation (SHOP-SIM) is 10 seconds. All the tests are run

on a Windows 10 laptop computer with an i7-6820HQ 2.70GHz processor, 16GB of RAM. CPLEX 12.6.3 is used to

solve the MILP optimization problem. Interested readers are referred to [5] for further details on the optimization.

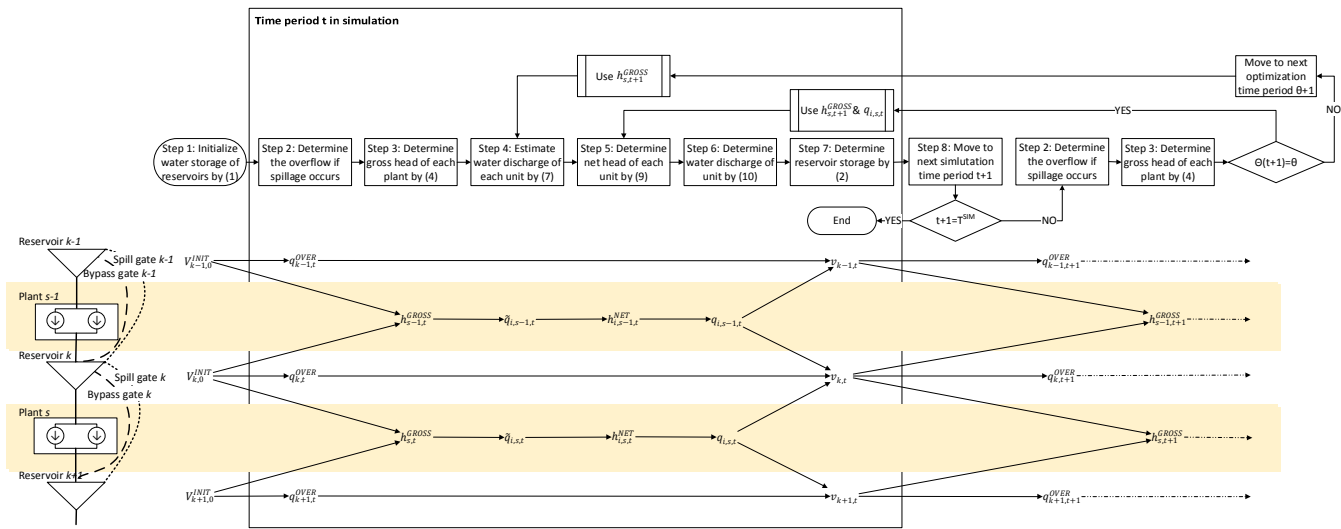

Figure 4. Illustration of the simulation process

TABLE II TEST CONFIGURATIONS AND THE CORRESPONDING OPTIMIZATION AND SIMULATION RESULTS

	Test Configurations			Optimization Results		Simulation Results
	Turbine efficiency η_i^{TURB}	Loss factor $\alpha_{n,s}$	Tailrace loss $\Delta h_{s,t}^{TAIL}$	Production	Discharge	Discharge
Test 1	Constant 90%	0	None	Run constantly at max production level	Increase stepwise	Increase continuously
Test 2	Piecewise-linear curve	0	None	Decrease stepwise	Run constantly at best efficiency point	Oscillate regularly
Test 3	Piecewise-linear curve	0.0005	None	Decrease stepwise	Run constantly at best efficiency point	Initial estimation is lower than the actual value but soon oscillate regularly
Test 4	Piecewise-linear curve	0.0005	The same as	Decrease stepwise	Run constantly at best efficiency point	Initial estimation is lower than the actual value but soon oscillate regularly

A. An Illustrative Case

The case in this section comprises three reservoirs, Reservoir1, Reservoir2, and Reservoir3, and two plants, Plant1 and Plant2, the same topology as the grey area in Figure 1. The reservoirs have a capacity of 10, 10, and 100 Million m^3 (Mm^3), respectively. Each power plant is equipped with two identical turbines. We assume the unit generator efficiency is constant 100%. The production intervals for all the units are [12 MW, 50 MW].

To effectively illustrate the properties of the simulation algorithm, we conduct 4 tests under alternative assumptions regarding the unit turbine efficiency, penstock loss factor and tailrace head loss (TABLE II). The production is determined by the optimization model and is the input data to the simulation model. The discharge in simulation as output result will be compared with the discharge in optimization to indicate the difference between the two models.

In the first test, we assume a completely linear system, no hydraulic loss in penstocks. The generating units have a constant turbine efficiency of 90%. The optimization result is to run both plants at constant maximum production (100 MW). In Figure 5 we compare the discharge in Plant1 after optimization and

simulation. Since the gross head of Plant1 is decreasing, to maintain a constant maximum production, Plant1 must increase its discharge slightly from one period to another in optimization. Due to the finer time resolution in simulation, we see that the increase in discharge is much smoother than the stepwise increase in optimization.

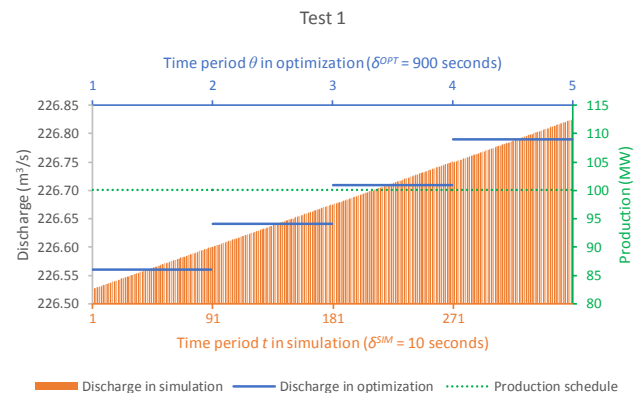

Figure 5. Optimization and simulation results of Test 1 at max production

In the second test, we represent the turbine efficiency as a piecewise-linear curve of the discharge. The three breakpoints at the minimum flow, best efficiency and maximum flow are shown in TABLE III. The same curve is used for all four turbines. Though it is still a simplified assumption, it is enough to capture the fundamental property of simulation.

TABLE III BREAKPOINTS ON TURBINE EFFICIENCY CURVE

Discharge (m ³ /s)	25.0	100.0	125.0
Efficiency (%)	80.0	90.0	85.0

As displayed in Figure 6, both turbines in Plant1 now operate at the best efficiency point of 100 m³/s as the result of optimization. Since the gross head of Plant1 is still decreasing, to keep the discharge at the constant best point, the production slightly decreases after each successive period in optimization. The discharge in simulation is calculated based on the value of production, and therefore, it oscillates regularly.

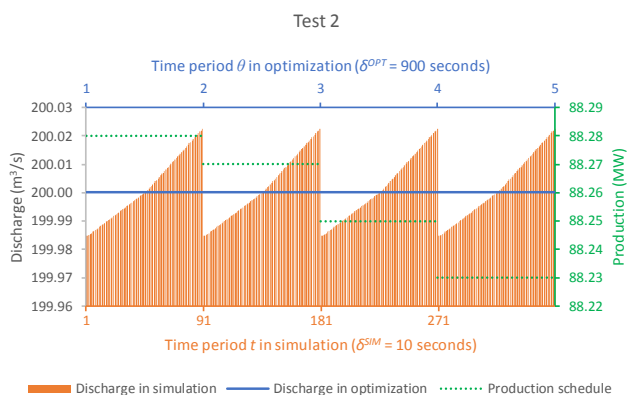

Figure 6. Optimization and simulation results of Test 2 at best efficiency

In the third test, we set the loss factor $\alpha_{n,s}$ to be 0.0005. With the gross head of about 50 m and the discharge of 100 m³/s, the head loss is around 10%, and hence, not neglectable. The initial estimation of the discharge in *Step 4* uses gross head for the energy conversion. This means that the simulated discharge for the first periods at each optimization time period θ will be too low, which can be seen as the dips in the detailed plot from Test 3 in Figure 7. However, the continuous updating of the net head in *Step 8* advances the convergence of the discharge within the following simulation time periods t .

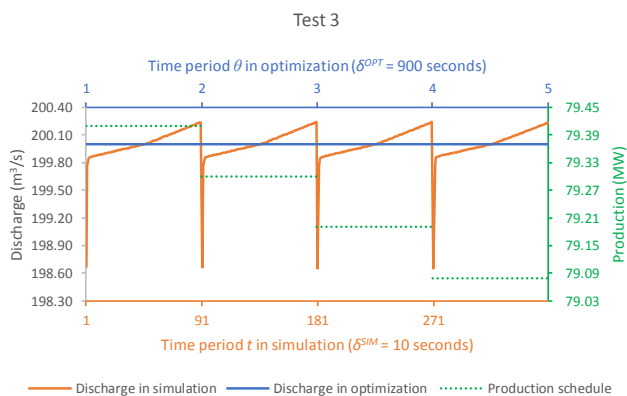

Figure 7. Optimization and simulation results of Test 3 with $\alpha_{n,s} = 0.0005$

As can be seen in both Figure 6 and Figure 7, the discharge in simulation swings along, rather than keep at, the best efficiency point. This means that the actual operating point fluctuates around the best efficiency point, and the average efficiency will be somewhat lower than that in optimization. The reduced efficiency results in higher water consumption to fulfil the production schedule, and a higher water consumption further decreases the head of the plant. This is a self-reinforcing effect that puts a limit on how far into the future the optimization results can trustworthily represent the real operations.

The self-reinforcing effect can be evidenced by the relative change in the water level of Reservoir1 in Figure 8. The accumulated difference between optimization and simulation after one week leads to significant deviation in the water level. However, since the optimization results are normally used for day-ahead scheduling, it is most important that they are valid for the first 24 hours (i.e. 86,400 seconds). The fact that how fast the deviation becomes unacceptable depends on the characteristics of each cascaded hydraulic system. Figure 8 contrastively illustrates how quick the deviation increases by the three tests. In Test 4, tailrace head loss description in is added.

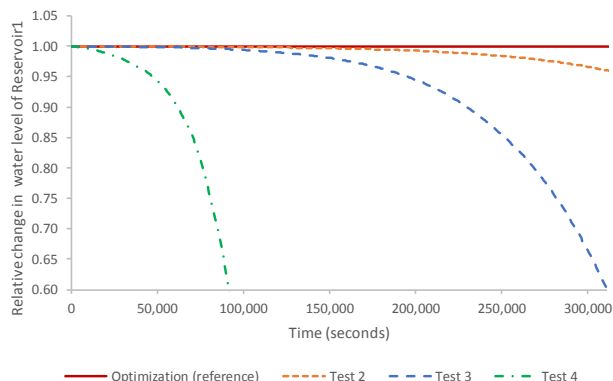

Figure 8. Relative change between optimization and simulation of the water level of Reservoir1

B. A Realistic Case

The second case is based on a real-size topology with 9 reservoirs and 7 plants in a cascaded river system (). The time resolution is still 15 minutes in optimization and 10 seconds in simulation. The purpose of the case study is to illustrate the role of simulation in the intraday re-planning.

We assume that the hydropower producer already has a feasible dispatch plan (original plan) for the watercourse. However, due to high uncertainty in the weather forecast, the hourly inflow prognosis for the small-sized Reservoir6 (maximum capacity 11.2 Million m³, Mm³) has been increased by 100 m³/s for the next 24 hours. The production planner wants to avoid spillage, and hence, needs to make an adjusted plan for the watercourse. There are three possible methods to achieve this purpose:

M1: to run a full re-optimization of the watercourse with the new inflow forecast. However, because of the limited time before the intraday trading closes, it is usually not feasible to spend the time needed to run a full re-optimization;

M2: to manually change the plan and input it as a production schedule to the optimization model. Then all the production variables in the optimization problem are fixed, and the calculation time is much shorter. The optimizer becomes a pure validation check of the schedules;

M3: to manually change the plan and check the feasibility by the the simulator.

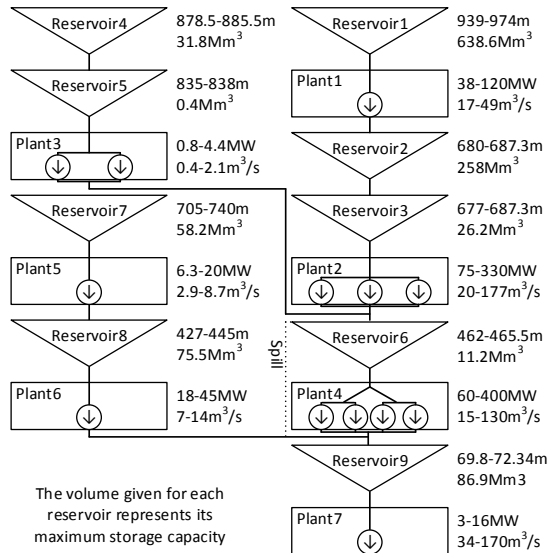

Figure 9. Topology for the realistic case study

To find the feasible manual plan, the production of Plant4 should be increased until there is no more spillage. For *M2* we use the optimization tool to verify the plan and stop when spillage disappears. However, when testing the final plan (without spillage in optimization) in the simulator, the higher precision demonstrates that there is still 0.14 Mm³ of spillage (Figure 10). In the similar manner, for *M3*, the simulator is used to determine the necessary increase of production in Plant4, and a more reliable manual plan is found.

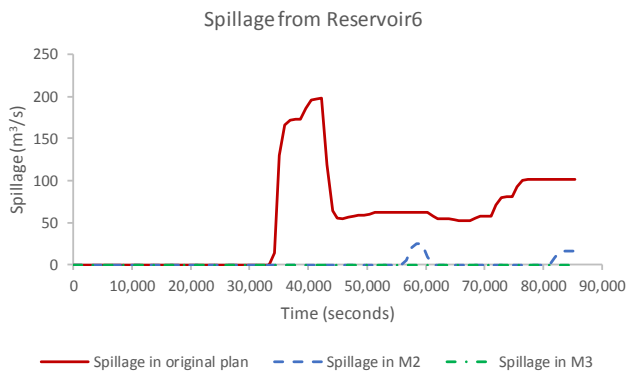

Figure 10. Spillage in original plan, *M2* and *M3* after updating inflow prognosis

As seen in 0, *M3* is the superior way to ensure that there is no spillage after manual re-planning. 0 also shows that the calculation time for checking the schedule feasibility is much lower in the simulation than in the optimization (typically reduced by a factor 100). This allows more iterations to be run to improve the manual plan within the same amount of time.

TABLE IV RESULTS OF RE-PLANNING

	Original Plan	<i>M1</i>	<i>M2</i>	<i>M3</i>
Time (s)	-	147	2.25	0.016
Spillage (Mm ³)	4.55	-	0.14	-

V. CONCLUSION

In this paper, we have presented the mathematical framework for a new operational hydropower simulator. Results show how the simulator can give a more precise calculation of the hydropower production functions compared to conventional linearized optimization models. The tests also demonstrate high computational efficiency in the simulator. The combination of precision and speed makes it a useful decision support tool for production planners. In addition to feasibility checking of manual plans, it is also valuable for validation of results from the optimization and can even be used to highlight needs for improved modelling in optimization when divergent results are found. One idea for further work is to improve the initial estimates of discharge in the simulator. A combination of optimization and simulation is another possibility for decision support when time is limited, and should be investigated in more details.

REFERENCES

- [1] E. N. Ni, X. H. Guan, and R. H. Li, "Scheduling hydrothermal power systems with cascaded and head-dependent reservoirs," *IEEE Trans. Power Systems*, vol. 14, no. 3, pp. 1127-1132, Aug. 1999.
- [2] E. C. Finardi and E. L. da Silva, "Solving the hydro unit commitment problem via dual decomposition and sequential quadratic programming," *IEEE Trans. Power Systems*, vol. 21, no. 2, pp. 835-844, May 2006.
- [3] A. L. Diniz and M. E. P. Maceira, "A four-dimensional model of hydro generation for the short-term hydrothermal dispatch problem considering head and spillage effects," *IEEE Trans. Power Systems*, vol. 23, no. 3, pp. 1298-1308, Aug. 2008.
- [4] R. Taktak and C. D'Ambrosio, "An overview on mathematical programming approaches for the deterministic unit commitment problem in hydro valleys," *Energy Systems-Optimization Modeling Simulation and Economic Aspects*, vol. 8, no. 1, pp. 57-79, Feb. 2017.
- [5] O. B. Fosso and M. M. Belsnes, "Short-term hydro scheduling in a liberalized power system," in *Proc. 2004 International Conference on Power System Technology - PowerCon*, vol. 2, pp. 1321-1326, Nov. 2004.
- [6] P. Ilak, S. Krajcar, I. Rajsl, and M. Delimar, "Pricing Energy and Ancillary Services in a Day-Ahead Market for a Price-Taker Hydro Generating Company Using a Risk-Constrained Approach," *Energies*, vol. 7, no. 4, pp. 2317-2342, Apr. 2014.
- [7] B. Tong, Q. Z. Zhai, and X. H. Guan, "An MILP Based Formulation for Short-Term Hydro Generation Scheduling With Analysis of the Linearization Effects on Solution Feasibility," *IEEE Trans. Power Systems*, vol. 28, no. 4, pp. 3588-3599, Nov. 2013.
- [8] J. Kong, H. I. Skjelbred, and H. Abgottsson, "Calculation of head loss in a shared tunnel for a pumped storage hydropower plant with variable speed pumps," in *HYDRO 2017*, Seville, Spain, 2017: The International Journal on Hydropower & Dams.
- [9] P. Lu, J. Z. Zhou, C. Wang, Q. Qiao, and L. Mo, "Short-term hydro generation scheduling of Xiluodu and Xiangjiaba cascade hydropower stations using improved binary-real coded bee colony optimization algorithm," *Energy Conversion and Management*, vol. 91, pp. 19-31, Feb. 2015.
- [10] A. Arce, T. Ohishi, and S. Soares, "Optimal dispatch of generating units of the Itaipu hydroelectric plant," *IEEE Trans. Power Systems*, vol. 17, no. 1, pp. 154-158, Feb. 2002.
- [11] O. B. Fosso, A. Gjelsvik, A. Haugstad, B. Mo, and I. Wangensteen, "Generation scheduling in a deregulated system. The Norwegian case," *IEEE Trans. Power Systems*, vol. 14, no. 1, pp. 75-80, Feb. 1999.