

# Linear mixed integer models for biomass supply chains with transport, storage and processing

**Silke van Dyken<sup>\*</sup>, Bjorn H. Bakken, Hans I. Skjelbred**

*SINTEF Energy Research, Sem Saelands vei 11, NO-7465 Trondheim, Norway*

Received

## **Abstract**

This paper presents a linear mixed integer modeling approach for basic components in a biomass supply chain including supply, processing, storage and demand of different types of biomass. The main focus in the biomass models lies on the representation of the relationship between moisture and energy content in a discretized framework and on handling of long term processes like storage with passive drying effects in the optimization. The biomass models are formulated consistently with current models for gas, electricity and heat infrastructures in the optimization model 'eTransport', which is designed for planning of energy systems with multiple energy carriers. To keep track of the varying moisture content in the models and its impact on other biomass properties, the current node structure in eTransport has been expanded with a special set of biomass nodes. The Node, Supply, Dryer and Storage models are presented in detail as examples of the approach. A sample case study is included to illustrate the functionality implemented in the models.

Keywords: Energy supply systems; Biomass; long term processes; linear mixed-integer models

# NOMENCLATURE

## Parameters

$\alpha_{sp}^{St}$	=	binary parameter to determine storage type (passive drying yes/no) for biomass product $p$
$c_d^{Dr}$	=	specific operating cost per $m^3$ biomass fed to dryer $d$ [USD/ $m^3$ ]
$c_s^{St}$	=	cost of biomass handling in storage $s$ [USD/timestep and $m^3$ ]
$C_{bpt}^{BSup}$	=	cost of biomass product $p$ from biomass supply $b$ in timestep $t$ [USD/ $m^3$ ]
$C_{sab}^{St}$	=	biomass handling cost in storage $s$ during the whole storage time $Tin_{sa}^{St} - Tout_{sb}^{St}$ [USD/ $m^3$ ]
$\delta_{sp}^{St}$	=	moisture reduction in storage $s$ for biomass product $p$ [% wt/timestep and $m^3$ ]
$\Delta_{spab}^{St}$	=	moisture reduction in storage $s$ for biomass product $p$ during the whole storage time $Tin_{sa}^{St} - Tout_{sb}^{St}$ , assuming a decreasing drying rate with increasing storage time [decimal fraction mass/ $m^3$ ]
$D_p^{ref}$	=	Reference density of product $p$ [ $kg/m^3$ ]
$D_p^{zero}$	=	Density of product $p$ , completely dry [ $kWh/m^3$ ]
$\varepsilon_{dp}^{Dr}$	=	volume loss coefficient for product $p$ in dryer $d$ [decimal fraction volume basis]
$\varepsilon_{sp}^{St}$	=	volume loss coefficient for biomass product $p$ in storage $s$ , average at storage starting point [decimal fraction volume basis/timestep]
$em_{de}$	=	emission coefficient for emission type $e$ from dryer $d$ [ $kg/MWh$ ]

---

\* Corresponding author. Tel.: + 47 73 55 04 47; fax: + 47 73 59 72 50.

$em_{se}$	=	emission coefficient for emission type $e$ from storage $s$ [kg/MWh]
$E_{spab}^{St}$	=	volume loss for biomass product $p$ in storage $s$ during the whole storage time $Tin_{sa}^{St} - Tout_{sb}^{St}$ , increasing with increasing storage time [decimal fraction volume basis/m <sup>3</sup> ]
$F_s^{St}$	=	Fuel use in storage $s$ per m <sup>3</sup> biomass input to run e.g. wheel loaders [liter/m <sup>3</sup> ]
$HV_p^{ref}$	=	Reference heating value of product $p$ [kWh/m <sup>3</sup> ]
$HVin_{dlp}^{Dr}$	=	heating value of biomass product $p$ for moisture pair $l$ to dryer $d$ in timestep $t$ [kWh/m <sup>3</sup> ]
$HVoil$	=	heating value of oil to dryer $d$ or storage $s$ [MWh/liter], global parameter
$MC_p^{ref}$	=	Reference moisture content of product $p$ [decimal fraction mass]
$MC_{bp}^{BSup}$	=	moisture content of biomass product $p$ from biomass supply $b$ [decimal fraction mass]
$MCI_d^{Dr}$	=	maximum input moisture content to dryer $d$ [decimal fraction mass]
$MCI_{dl}^{Dr}$	=	input moisture in moisture pair $l$ in dryer $d$ (linearization) [decimal fraction mass]
$MC \max_{np}^{No}$	=	maximum moisture content of product $p$ in Biomass Node $n$ [decimal fraction mass]
$MC \min_{np}^{No}$	=	minimum moisture content of product $p$ in Biomass Node $n$ [decimal fraction mass]
$MCO_d^{Dr}$	=	lowest level of output moisture content achievable in dryer $d$ [decimal fraction mass]
$MCO_{dl}^{Dr}$	=	output moisture in moisture pair $l$ in dryer $d$ (discretization)

		[decimal fraction mass]
$MCstep_d^{Dr}$	=	moisture reduction in dryer $d$ per discretization step
		[decimal fraction mass]
$N^T$	=	total number of timesteps
$Nli_d^{Dr}$	=	number of discretization points in the dryer model (moisture)
$Npairs_d^{Dr}$	=	number of discretization pairs in the dryer model (moisture)
$Nsteps_d^{Dr}$	=	number of discretization steps in the dryer model (moisture)
$Nbv_d^{Dr}$	=	number of discretization points in the dryer model (biomass burned)
$Pen_{de}^{Em}$	=	Emission penalty for emission type $e$ from dryer $d$ [USD/kg]
$Pen_{se}^{Em}$	=	Emission penalty for emission type $e$ from storage $s$ [USD/kg]
$q_{dp}^{Dr}$	=	specific energy required in dryer $d$ to evaporate one kg water from biomass product $p$ [kWh/kg]
$Qmax_{dp}^{Dr}$	=	rated capacity of dryer $d$ for biomass product $p$ [MW]
$\sigma_{dlp}^{Dr}$	=	specific energy required to dry biomass product $p$ in dryer $d$ for all moisture pairs $l$ [MWh/kg]
$Tin_{sa}^{St}$	=	input timestep to storage $s$ in timestep $a$
$Tout_{sb}^{St}$	=	output timestep from storage $s$ in timestep $b$
$Vmax_{bp}^{BSup}$	=	maximum flow of biomass product $p$ from biomass supply $b$ [m <sup>3</sup> /timestep]
$Vmax_{dp}^{Dr}$	=	maximum flow of biomass product $p$ to dryer $d$ [m <sup>3</sup> /timestep]
$Vbmax_d^{Dr}$	=	maximum volume of biomass burned in dryer $d$ [m <sup>3</sup> /timestep]
$VB_{dv}^{Dr}$	=	amount of biomass burned in dryer $d$ at discretization point $v$ in $Burn$ [m <sup>3</sup> /timestep]
$Vmax_s^{St}$	=	maximum flow of biomass to storage $s$ [m <sup>3</sup> /timestep]

$V \min_{bp}^{BSup}$  = minimum flow of biomass product  $p$  from biomass supply  $b$  [ $m^3$ /timestep]

$Wevap_{dp}^{Dr}$  = amount of water evaporated in dryer  $d$  from biomass product  $p$  per  
moisture step  $MCstep_d^{Dr}$  [ $kg/m^3$ ]

### Variables

$Bio\_load\_flow_{ijpt}$  = Biomass volume flow of product  $p$  from network node  $i$  to load  
node  $j$  in timestep  $t$  [ $m^3$ /timestep]

$Bio\_local\_flow_{ijpt}$  = Biomass volume flow of product  $p$  from supply node  $i$  to load node  
 $j$  in timestep  $t$  [ $m^3$ /timestep]

$Bio\_net2net\_flow_{ijpt}$  = Biomass volume flow of product  $p$  from network node  $i$  to  $j$  in  
timestep  $t$  [ $m^3$ /timestep]

$Bio\_supply\_flow_{ijpt}$  = Biomass volume flow from supply node  $i$  to network node  $j$  in  
timestep  $t$  [ $m^3$ /timestep]

$C^Z$  = operating cost for different technologies,  $Z \in Technologies$

$D_{npt}^{No} \geq 0$  = density of biomass product  $p$  in node  $n$  in timestep  $t$  [ $kg/m^3$ ]

$Emit_{edt} \geq 0$  = Amount of emission type  $e$  from dryer  $d$  in timestep  $t$  [ $kg$ /timestep]

$Emit_{est} \geq 0$  = Amount of emission type  $e$  from storage  $s$  in timestep  $t$  [ $kg$ /timestep]

$F_{dpt}^{Dr} \geq 0$  = Fuel (oil) used by dryer  $d$  in timestep  $t$  to dry biomass product  $p$   
[liter/timestep]

$HV_{npt}^{No} \geq 0$  = density of biomass product  $p$  in node  $n$  in timestep  $t$  [ $kg/m^3$ ]

$Load\_flow_{ijt}$  = Energy flow from network node  $i$  to load node  $j$  in timestep  $t$   
[MWh/timestep]

$Local\_flow_{ijt}$  = Energy flow from supply node  $i$  to load node  $j$  in timestep  $t$   
[MWh/timestep]

- $\lambda_{dlvt}^{Dr}$  = binary variable for discretization of moisture pair  $l$  and burned volume  $v$  in dryer  $d$  and timestep  $t$ , the value is 1 if moisture pair  $l$  is chosen, 0 if not
- $\lambda_{spab}^{St}$  = binary variable to determine how long ( $tin_{sa}^{St} - tout_{sb}^{St}$ ) a biomass product  $p$  has to be stored in storage  $s$  to reach a certain output moisture level, the value is 1 if input time is  $tin_{sa}^{St}$  and output time is  $tout_{sb}^{St}$ , 0 if not
- $MC_{npt}^{No} \geq 0$  = biomass moisture content of product  $p$  in biomass node  $n$  in timestep  $t$   
[decimal fraction mass]
- $MCin_{dpt}^{Dr} \geq 0$  = biomass input moisture content of product  $p$  to dryer  $d$  in timestep  $t$   
[decimal fraction mass]
- $MCin_{spt}^{St} \geq 0$  = biomass input moisture content of product  $p$  to storage  $s$  in timestep  $t$   
[decimal fraction mass]
- $MCout_{dpt}^{Dr} \geq 0$  = biomass output moisture content of product  $p$  from dryer  $d$  in timestep  $t$   
[decimal fraction mass]
- $MCout_{spt}^{St} \geq 0$  = biomass output moisture content of product  $p$  from storage  $s$  in timestep  $t$   
[decimal fraction mass]
- $Net2net\_flow_{ijt}$  = Energy flow from network node  $i$  to  $j$  in timestep  $t$  [MWh/timestep]
- $P_{jit}^{N2N}$  = power flow in timestep  $t$  from/to other network models at node  $i$   
[MWh/timestep]
- $P_{sit}^{Sup}$  = power flow in timestep  $t$  from local supply connected at node  $i$   
[MWh/timestep]
- $Q_{dpt}^{Dr} \geq 0$  = amount of energy required to dry biomass product  $p$  in dryer  $d$  and timestep  $t$  [MWh/timestep]
- $Qex_{dt}^{Dr} \geq 0$  = external drying heat to dryer  $d$  in timestep  $t$  [MWh/timestep]
- $Supply\_flow_{ijt}$  = Energy flow from supply node  $i$  to network node  $j$  in timestep  $t$

		[MWh/timestep]
$V_{bpt}^{BSup} \geq 0$	=	Amount of biomass product $p$ supplied in timestep $t$ from supply $b$
$V_{pnl}^{Ld}$	=	Biomass flow of product $p$ in timestep $t$ to load $l$ connected to node $n$
		[m <sup>3</sup> /timestep]
$V_{pnj}^{N2N}$	=	Biomass flow of product $p$ in timestep $t$ from/to other network models $j$ at node $n$ [m <sup>3</sup> /timestep]
$V_{psn}^{Sup}$	=	Biomass flow of product $p$ in timestep $t$ from biomass supply $s$ connected at node $n$ [m <sup>3</sup> /timestep]
$Vb_{dpt}^{Dr} \geq 0$	=	amount of biomass product $p$ burned in dryer $d$ and timestep $t$ to supply drying heat [m <sup>3</sup> /timestep]
$Vin_{dpt}^{Dr} \geq 0$	=	input volume of biomass product $p$ to dryer $d$ in timestep $t$ [m <sup>3</sup> /timestep]
$Vin_{spt}^{St} \geq 0$	=	input volume of biomass product $p$ to storage $s$ in timestep $t$ [m <sup>3</sup> /timestep]
$Vout_{dpt}^{Dr} \geq 0$	=	output volume of biomass product $p$ from dryer $d$ in timestep $t$
		[m <sup>3</sup> /timestep]
$Vout_{spt}^{St} \geq 0$	=	output volume of biomass product $p$ from storage $s$ in timestep $t$
		[m <sup>3</sup> /timestep]
$Vtrans_{spab}^{St} \geq 0$	=	transferred volume of biomass product $p$ in storage $s$ between timestep $a, b$
		[m <sup>3</sup> /timestep]
$t, a, b,$	=	Index for timesteps within operational model, $t, a, b \in Time\_steps$

## Sets

<i>BioSupplies</i>	=	Set of biomass supplies
<i>BioNodes</i>	=	Set of biomass nodes
<i>Burn</i>	=	Set of all values for linearization of the amount of biomass burned in the Dryer model
<i>Dryers</i>	=	Set of biomass dryers
<i>Emissions</i>	=	Set of (predefined) emission types; $Emissions = [CO_2, CO, NO_x, SO_x]$
<i>Index</i>	=	Index set for calculation of specific drying energy in dryer model
<i>Load_points</i>	=	Set of load and market nodes
<i>Net2load</i>	=	Set to define connections between network nodes and load nodes
<i>Net2net</i>	=	Set to define connections between two different networks $t$
<i>Network_nodes</i>	=	Set of network nodes
<i>Pairs</i>	=	Set of all discretization moisture pairs in the Dryer model
<i>Products</i>	=	Set of all biomass products
<i>Storages</i>	=	Set of biomass storages
<i>Supply_points</i>	=	<i>Set of energy sources</i>
<i>Supply2load</i>	=	Set to define direct connections between supply nodes and load nodes
<i>Supply2net</i>	=	Set to define connections between supply nodes and network nodes
<i>Time_steps</i>	=	Set of hours in the operational model (circular)



# 1 INTRODUCTION

Biomass can be defined as organic matter that has been directly or indirectly derived from contemporary photosynthesis reactions, and hence can be considered a part of the present carbon cycle. It is considered a renewable resource when utilized in a sustainable way (harvesting equals re-growth). Many countries have large biomass resources, and it is considered as one of the most promising renewable energy sources in the near to mid-term perspective. Forest biomass represents the largest energy resource, but biomass can also be produced by dedicated cultivation, i.e. energy farming. By-products from forestry and agriculture can also be used for energy purposes, referred to as biomass waste. Examples of such waste sources are maintenance work in parks and gardens, thinning wood from forestry and straw from wheat farming. There are also general waste streams from household and industry, which include biomass products like food, paper, demolition wood and saw dust.

The generic term 'biomass' is used on a wide and diverse range of energy resources that can be used in solid or gasified form for heating applications or electricity production, or in liquid or gasified form as transportation fuel. E.g. 5–8 assortments of forest species will diverge into 30–60 log types and 100 – 200 raw products. In the end of a general biomass supply chain, the number of products may become many thousands. Thus, it is not sufficient to set up a techno-economic optimization model where flow of generic 'biomass' is considered in the same way as flow of electricity, heat or natural gas. Large international research programs are initiated to develop efficient technologies for increased utilization of biomass resources both for stationary and mobile use ([1], [2]). Compared to more traditional energy transport technologies like electricity and gas, however, fewer efforts have so far been apparent in techno-economic modeling and optimization of biomass supply chains. Most reports and studies ([3]-[8]) show numerical assessments on specific biomass activities and technologies necessary to meet energy demand. Although many have an energy system approach, few actually use a model that

accounts for the many trade offs and the alternative handling options in the design of a general biomass supply chain.

A detailed dynamic simulation program for collection and transportation of large quantities of biomass, the IBSAL model, is presented in [3]. The model considers time-dependent availability of biomass under the influence of weather-conditions and predicts the number and size of equipment needed to meet a certain demand. The delivered cost of biomass is calculated based on the utilization rate of the machines and storage spaces. The model uses nonlinear equations to describe the dependencies, e.g. a third-degree polynomial to represent the moisture content as a function of number of days since the start of harvest.

A rather simple nonlinear decision support model is given in [4]. The problem considered is optimal exploitation of biomass resources with several harvesting sites and a few centralized combustion plants on a regional level. The aim is to find the optimal capacity of heat and power generation as well as the optimal utilization of biomass resources and transport options. The time horizon considered is one year so that the model is capable of giving long term decision support.

Another modeling approach describes a methodology for optimization of agricultural supply chains by dynamic programming (DP) [5] to find the lowest cost from harvest to end use. The DP model works by defining a set of stages of the supply chain and stages for the biomass. The model explicitly deals with the product properties, which are influenced by handling, processing, transportation and storage actions.

The work presented in [6] describes an environmental decision support system (EDDS) based on a geographic information system (GIS). The optimization model used can be classified as a non-linear mixed integer programming problem. The main focus is the optimal planning of forest

biomass use for energy production. Different scenarios can be analyzed over a long-time period supported by a user interface.

The model described in [7] focuses on biomass collection and transportation systems and presents a multicriteria assessment model. Economic, social, environmental and technical factors are included in the ranking of the alternatives investigated. Another mixed-integer linear optimization model is demonstrated in [8]. The methodology allows for biomass management for energy supply on a regional level. The model is based on the dynamic evaluation of economic efficiency and the objective is to find the most economical and ecological supply structure.

Both [9] and [10] analyze logistic issues of biomass and present the application of the concepts developed in case studies. The work in [9] deals with the storage problem and the advantages a multi-biomass supply chain might have on the logistic cost. The objective of [10] was the development of a forest biomass supply logistics model.

In this paper, we present a linear mixed integer modeling framework that can be applied to most relevant components in a biomass supply chain, including sources, handling/processing, storage and end use. Characteristic for our generic model is its flexible structure which allows for the modeling of value chains with multiple biomass types and technologies. The modeling framework is based on an approach with a network node system applied in [16] and [17]. The main objective of our approach is the presentation of the new functionality. Minor focus has been given to an application with real case data.

The amount of energy flowing (and specific operating cost) at any point in the supply chain depends both on the volume and the moisture content in the biomass, and can be defined as a function of two main properties of the biomass product [5]:

- *Appearance*; describing if the biomass is in chips, pellets, logs etc
- *Quality*; primarily moisture content

The following types of actions can then be distinguished [5]:

- *Handling*; actions that intentionally alter or modify the appearance of a product, e.g. chipping or pelleting
- *Processing*; actions which intentionally alter or modify the quality of a product, e.g. drying
- *Transportation and storage*; actions which unintentionally alter the quality of a product, e.g. natural drying during long-term storage

In the current framework, we do not distinguish between handling and processing. The main issue during optimization is to keep track of what kind of changes a specific action or module does to the product, both in terms of quality and appearance.

Furthermore, the long-term effects of passive drying (change of quality) during storage has to be considered together with forced drying in a processing module. The typical hourly and seasonal load profiles used for optimization of heat and electricity supply thus have to be modified to allow the algorithm to choose between cheap/free long-term passive drying and spending fuel for forced and fast drying.

The paper is organized as follows: Section 2 gives a brief overview of the eTransport optimization model and the basic network structure, section 3 describes the new biomass model structure with the biomass node system. The Supply, Dryer and Storage models are presented in detail as samples of the methodology. Section 4 contains a sample case study to demonstrate the

properties of the new biomass models. Section 5 contains aspects of discussion and Section 6 an explanation of current and further work.

## 2 THE ETRANSPORT MODEL

The optimization model *eTransport* is developed for expansion planning in energy systems where several alternative energy carriers and technologies are considered simultaneously [11]-[14]. The model uses a detailed network representation of technologies and infrastructure to enable identification of single components, cables and pipelines. The current version optimizes investments in infrastructure over a planning horizon of 10 to 30 years for most relevant energy carriers and conversion between these. It is not limited to continuous transport like lines, cables and pipelines, but can also include discrete transport by ship, road or rail.

The model is separated into an *operational model* (energy system model) and an *investment model* where both economical and environmental aspects are handled by a superior modeling structure [14]. In the operational model there are sub-models for each energy carrier and for conversion components. With the presented biomass module, several new sub-models have been added to the operational model. The operational planning horizon is relatively short (1-3 days) with a typical time-step of one hour. The operational model finds the cost-minimizing diurnal operation for a given infrastructure and for given energy loads. Annual operating costs for different energy system designs are calculated by solving the operational model repeatedly for different seasons/segments (e.g. peak load, low load, intermediate etc), investment periods (e.g. 5 year intervals) and relevant system designs. Annual operating and environmental costs for all different periods and energy system designs are then used by the *investment model* to find the investment plan that minimizes the present value of all costs over the planning horizon.

Mathematically, the model uses a combination of linear programming (LP) and mixed integer programming (MIP) for the operational model, and dynamic programming (DP) for the investment model. The operational model is implemented in the AMPL programming language with CPLEX as solver [15], while the investment model is implemented in C++. A modular design ensures that new technology modules developed in AMPL for the operational model are automatically embedded in the investment model. A full-graphical Windows interface is developed for the model in MS Visio. All data for a given case are stored in a database. The sub-models for different components are connected by general energy flow variables that identify the flow between energy sources (*Supply\_points*), network components for transport, conversion and storage (*Network\_nodes*) and energy sinks like loads and markets (*Load\_points*). The connections between supply points, network nodes and load points are case-specific, and they are identified by sets of pairs where each pair shows a possible path for the energy flow between component types:

<i>Supply2net:</i>	Set of pairs $(i, j)$ , where $i \in \text{Supply\_points}$ and $j \in \text{Network\_nodes}$
<i>Supply2load:</i>	Set of pairs $(i, j)$ , where $i \in \text{Supply\_points}$ and $j \in \text{Load\_points}$
<i>Net2net:</i>	Set of pairs $(i, j)$ , where $i, j \in \text{Network\_nodes}$
<i>Net2load:</i>	Set of pairs $(i, j)$ , where $i \in \text{Network\_nodes}$ and $j \in \text{Load\_points}$

General energy flow variables are defined over the energy system structure to account for the actual energy flow between different components (except for internal flow within each model). These general variables are included in and restricted by the various models and they are the link between the different models:

<i>Supply_flow<sub>ijt</sub>:</i>	Energy flow from $i$ to $j$ at $t$ , where $(i, j) \in \text{Supply2net}$ and $t \in \text{Time\_steps}$
<i>Local_flow<sub>ijt</sub>:</i>	Energy flow from $i$ to $j$ at $t$ , where $(i, j) \in \text{Supply2load}$ and $t \in \text{Time\_steps}$
<i>Net2net_flow<sub>ijt</sub>:</i>	Energy flow from $i$ to $j$ at $t$ , where $(i, j) \in \text{Net2net}$ and $t \in \text{Time\_steps}$

$Load\_flow_{ij,t}$ : Energy flow from  $i$  to  $j$  at  $t$ , where  $(i, j) \in Net2load$  and  $t \in Time\_steps$

In the *operational model*, the different technology models are added together to form a single linear mixed integer optimization problem. The object function is the sum of the contributions from the different models and the restrictions of the problem include all the restrictions defined in the models. Emissions are caused by a subset of components (power plants/CHP, boilers, road/ship transport etc) that are defined as emitting  $CO_2$ ,  $NO_x$ ,  $CO$  and  $SO_x$ . Further environmental consequences can be defined. Emissions are calculated for each module and accounted for as separate results. When emission penalties  $Pen^{Em}$  are introduced by the user (e.g. a  $CO_2$  tax), the resulting costs are included in the objective function and thus added to the operating costs.

The task for the *investment model* is to find the optimal set of investments during the period of analysis, based on investment costs for different projects and the pre-calculated annual operating costs for different periods and states. The optimal investment plan is defined as the plan that minimizes the discounted present value of all costs in the planning period, i.e. operating costs plus investment costs minus the rest value of investments. The optimal plan will therefore identify the optimal design of the energy system (i.e. the optimal state) in different periods.

More details of the investment algorithm and the emission handling in eTransport are previously published in [14] and will not be presented here.

### **3 BIOMASS IN ETRANSPORT**

When analyzing a biomass supply chain, it is of great importance to consider the effects associated with the variation of moisture content for a vast variety of materials. Ensuring that the moisture content of the biomass entering or leaving a process is within a certain range is

essential for the proper operation and efficiency of conversion technologies, as for instance combustion or fast pyrolysis plants. The original version of eTransport only takes the flow of energy from one node to another into account (node types: *Supply\_points*, *Network\_nodes* and *Load\_points*). However, with biomass, the amount of energy flowing from one node to another depends both on the volume flow and the moisture content. The biomass density and the heating value are additional key parameters. Thus, in contrast to the original LP structure of eTransport, more than one variable has to be handled during the optimization. This leads to a non-linear problem which has to be discretized to be able to carry out the LP-optimization. To keep track of the variables of volume and moisture throughout the system a new set *BioNodes* has been defined in addition to the common network nodes. This set assures consistency between connected components of the biomass module. The same modeling approach is applied in [16] and [17] to describe the technological characteristics of natural gas flows in pipelines in combination with optimization of gas markets. The approach is based on a network node system which allows for the control of both the gas flow and the pressure. This network structure has already been applied in the gas models in eTransport. However, since the control of both the gas flow and the system pressure is similar to the interdependent variables which have to be handled in a biomass chain, the gas network modeling approach has been transferred to the biomass module.

Aside from the interdependent variables, the modeling of biomass processes differs from the original design in eTransport by the occurrence of long term effects. Compared to the analysis of electricity networks, long term processes and seasonal variation (harvest period, amount of biomass available, weather conditions, etc.) play a major role in a study of a biomass supply chains. Biomass properties will change in a long term perspective, mainly due to passive drying effects and degradation processes. The typical time resolution in the operational model in eTransport is one hour [14], suitable for a detailed analysis of e.g. electricity networks, but it is not appropriate when analyzing biomass processes. Furthermore, the current investment module



does not allow for the optimization of long term processes since the information given/obtained about operating conditions and material properties in one year or segment can not be transferred to another year or segment.

However, an approach to modeling the long-term effects can be made by using the functionality existing in the short term structure. The default time resolution in the operational model is on an hourly basis with 24 timesteps, but this can be changed freely. Thus, time dependent variables are defined per timestep in the nomenclature. By choosing 52 timesteps and one single segment the model will optimize the operation of the system for a whole year on a weekly basis (input values = weekly average values). With such a weekly time resolution, the long term functions implemented in the biomass chains can be handled by the operational optimization.

With the *BioNodes* as a connecting basic structure, seven new technology models are implemented in in eTransport:

- 1) *Supply*: Different kinds of biomass supplied to the system with moisture levels defined by the user, varying cost profile and restricted volume.
- 2) *Chipping*: Grinding/chipping of solid biomass to user-defined quality/appearance.
- 3) *Pellets Plant*: Production of pellets with user-defined properties.
- 4) *Storage*: Storage of biomass with passive drying function (optional). Might cause emissions due to internal units (oil-fired) for biomass handling.
- 5) *Dryer*: Active drying of biomass. Causes emissions when oil-fired.
- 6) *Combustion*: Heat production in a large scale biomass boiler, co-fired with oil (optional), causes emissions.
- 7) *Demand*: Biomass load point, demand of biomass volume at a certain moisture and quality level.

The symbolic technology models and the symbolic biomass node are shown in Fig. 1. Some of the models originate from [18], but have been further developed and adjusted to the new node structure. In the following sections, the basic structure of the biomass module and the LP formulations for the *BioNodes*, the *Supply*, the *Dryer* and the *Storage* model are presented in detail. The model description is followed by a case study to illustrate the new functionality and possible model applications.

### 3.1 Basic biomass module structure and Biomass Nodes

To be able to handle both the basic characteristics of different kinds of biomass and the effects the variation in moisture content might have on these properties, a set of different *Products* is created. For each  $p \in Products$ , a reference point is specified defining the following reference parameters:

- the *moisture content*  $MC_p^{ref}$ ,
- the *bulk density*  $D_p^{ref}$
- and the *heating value*  $HV_p^{ref}$

The common flow variables used to model the flow in the eTransport network are (as presented in chapter 2): *Supply\_flow<sub>ijt</sub>*, *Local\_flow<sub>ijt</sub>*, *Net2net\_flow<sub>ijt</sub>* and *Load\_flow<sub>ijt</sub>*. These variables only take into account the flow of energy [MWh/h] between two points *i* and *j* in the network in different timesteps *t*. That is not sufficient in a biomass model, since information about the moisture content at various steps in the chain is crucial for the optimization. For that reason, each of the four common flow variables in eTransport has been extended with a forth index  $p \in Products$  to be able to represent the product properties. Thus, information about moisture content is given and transferred between the models and the *BioNodes* in the network. In contrast to the common flow variables, the flow between the biomass models in the network is a volume

flow [m<sup>3</sup>/h] and not a flow of energy. The extended flow variables are only valid in the biomass module.

*Bio\_supply\_flow<sub>ijpt</sub>* Biomass volume flow of product  $p$  from  $i$  to  $j$  at  $t$ , where  $(i, j) \in Supply2net$ ,  $p \in Products$  and  $t \in Time\_steps$

*Bio\_local\_flow<sub>ijpt</sub>* Biomass volume flow of product  $p$  from  $i$  to  $j$  at  $t$ , where  $(i, j) \in Supply2load$ ,  $p \in Products$  and  $t \in Time\_steps$

*Bio\_net2net\_flow<sub>ijpt</sub>* Biomass volume flow of product  $p$  from  $i$  to  $j$  at  $t$ , where  $(i, j) \in Net2net$ ,  $p \in Products$  and  $t \in Time\_steps$

*Bio\_load\_flow<sub>ijpt</sub>* Biomass volume flow of product  $p$  from  $i$  to  $j$  at  $t$ , where  $(i, j) \in Net2load$ ,  $p \in Products$  and  $t \in Time\_steps$

By means of the biomass node structure, the quality variable moisture content  $MC_{npt}^{No}$  is controlled in addition to the biomass volume flow. This requires the connection of each biomass model to a biomass node. In this way, it can be accounted for that changes in one part of the system might influence the performance of the rest of the system. Extended passive storage keeping could for example shorten the residence time in a dryer which in turn influences the operating cost of the whole system.

The moisture content is modeled as a free variable which can be restricted by different sets of parameters in the biomass nodes and in the technology models. The biomass density and the heating value are not separately restricted since these values are directly linked to the moisture content assuming linear dependencies. The biomass density in a node is linked to the moisture content by assuming a linear dependency:

**Error!**

**Book**

**mark**

**not**

**define**

**d.(1)**

$$D_{npt}^{No} = D_p^{ref} \frac{1 + MC_{npt}^{No}}{1 + MC_p^{ref}}$$

$$\forall n \in BioNodes, p \in Products, t \in Time\_steps$$

The density of completely dry biomass ( $MC_{npt}^{No} = 0$ ) is defined as  $D_p^{zero}$ .

$$D_p^{zero} = \frac{D_p^{ref}}{1 + MC_p^{ref}} \quad (2)$$

$$\forall p \in Products$$

Applying the formulation of  $D_p^{zero}$  to Eq. (1), the linear dependency of biomass moisture content and density can be expressed by

$$D_{npt}^{No} = D_p^{zero} (1 + MC_{npt}^{No}) \quad (3)$$

$$\forall n \in BioNodes, p \in Products, t \in Time\_steps$$

The dependency of the biomass heating value on the moisture content is modeled by linearization of the relation shown in Fig. 2. It is assumed that the correlation applies to all kinds of biomass. The curve shown for spruce is taken as a reference curve. It is divided into three linear parts using four linearization points (more points possible for increased accuracy). The linearized curve for spruce is scaled up and down to represent other biomass types  $p \in Products$  using the corresponding reference values  $MC_p^{ref}$  and  $HV_p^{ref}$ .

Three different definitions are common for the heating value of biomass:

- HHV (higher heating value) which is the gross heating value
- LHV (lower heating value) which is the net heating value. In contrast to the HHV, the LHV does not include the heat which originates from the water vapor formed during the combustion
- EHV (effective heating value) is the LHV subtracting the energy of evaporating the moisture content of the biomass

The relation shown in Fig. 2 is based on the EHV, but the reference heating values defined in the model do not necessarily have to be the EHV. Since the dependency found based on Fig. 2 is an approximation, it is also possible to use the LHV or HHV as long as this choice is consistent in the whole model. Furthermore, it has to be considered that the heating values available for different kinds of biomass often represent average values. This is caused by the wide variation of biomass quality.

There are no operating costs associated with the biomass node model

$$C^{No} = 0. \quad (4)$$

The biomass node model does not represent a physical technology model. It is implemented to enable the transfer of biomass property information between the network models and to keep track of the biomass flow and the variation in moisture content. Thus, neither the biomass volume flow nor the three quality variables are modified in the biomass node model. The amount of biomass that goes into a biomass node equals the amount of biomass that leaves it. The mass balance equation for a biomass node  $n \in BioNodes$  is given by

$$\sum_{i:(i,n) \in \text{Supply2net}} V_{inpt}^{Sup} + \sum_{j:(j,n) \in \text{Net2net}} V_{jnpt}^{N2N} = \sum_{l:(n,l) \in \text{Net2load}} V_{nlpt}^{Ld} + \sum_{j:(n,j) \in \text{Net2net}} V_{njpt}^{N2N} \quad (5)$$

$$\forall n \in \text{BioNodes}, p \in \text{Products}, t \in \text{Time\_steps}.$$

### 3.2 Supply model

The biomass supply model is a generic source that accounts for cost and moisture content of any biomass product  $p$ . The output volume  $V_{bpt}^{BSup}$  can not exceed the maximum output capacity. At the same time, the minimum output conditions have to be kept.

$$V \min_{bp}^{BSup} \leq V_{bpt}^{BSup} \leq V \max_{bp}^{BSup} \quad (6)$$

$$\forall bn \in \text{BioSupplies}, p \in \text{Products}, t \in \text{Time\_steps}$$

The cost of using biomass is given by

$$C^{BSup} = \sum_{t \in \text{Time\_steps}} \sum_{b \in \text{BioSupplies}} \sum_{p \in \text{Products}} C_{bpt}^{BSup} V_{bpt}^{BSup}. \quad (7)$$

The biomass taken from a given supply point has to be fed to a biomass node. The special properties of the biomass node system only take effect when each model belonging to the biomass chain is connected to a biomass node. Thus, the biomass balance for the biomass supply point is

$$V_{bpt}^{BSup} = \sum_{i:(b,i) \in \text{Supply2net}} V_{bipt}^{Sup} \quad (8)$$

$$\forall b \in \text{BioSupplies}, p \in \text{Products}, t \in \text{Time\_steps}.$$

Eq. (8) restricts the biomass volume flow from the biomass supply to the network. In addition, information about the moisture content has to be transferred to the network. The moisture

content in the biomass supply is set equal to the moisture content in the biomass node connected to the supply point. This is done applying the general node structure and the set “*Supply2net*”.

$$MC_{bp}^{BSup} = \text{if } n \in \text{BioNodes} \text{ then } MC_{npt}^{No} \\ \text{else } MC_{bp}^{BSup} \quad (9)$$

$$\forall b \in \text{BioSupplies}, (b,n) \in \text{Supply2net}, p \in \text{Products}, t \in \text{Time\_steps}$$

### 3.3 Dryer model

The dryer model reduces the moisture content of a biomass product  $p$ . The heat required to run the drying process can either be supplied by an external heat source, by direct burning of biomass or oil, or a combination of these. The amount of biomass dried in the model is restricted by the maximum biomass feed rate  $V \max_{dp}^{Dr}$  to the dryer [m<sup>3</sup>/h]. In addition, it is restricted by its rated capacity  $Q \max_{dp}^{Dr}$  [MW] and the drying rate  $q_{dp}^{Dr}$  [kWh/kg water evaporated]. The drying rate, which is defined by the user, is treated as an average rate. It is assumed that the energy required to evaporate the biomass moisture slightly increases when the drying is carried out on a low moisture level. Hence, reducing the moisture content from 60 %wt to 50 %wt requires less energy than reducing it from 20 %wt to 10 %wt. Volume losses during the drying process are accounted for applying the volume loss coefficient  $\varepsilon_{dp}^{Dr}$  (percentage of input volume). In addition to the energy costs calculated in the energy supply models, a specific operating cost  $c_d^{Dr}$  per m<sup>3</sup> biomass fed to the dryer can be specified.

The optimization of the amount of biomass fed to the dryer and both the variable input and output moisture level leads to a non-linear problem which has to be discretized. This is done using a set of predefined pairs of possible input and output moisture content combinations,

$MCI_{dl}^{Dr}$  and  $MCO_{dl}^{Dr}$ . The user defines the number of discretization points between the maximum

input moisture level  $MCi_d^{Dr}$  and the lowest output moisture level achievable in the dryer  $MCo_d^{Dr}$ .

The moisture pairs are generated automatically in the model. A numerical example with the definition of  $MCstep_d^{Dr}$  is shown in Table 1. The optimal moisture pair is found by means of the binary variable  $\lambda_{d/vt}^{Dr}$ .

The heat required in the drying process can be obtained by burning a fraction of the biomass.

The biomass volume required to cover the drying heat depends on the heating value of the biomass. Again, the heating value is linked to the moisture content which is not known before the optimization is carried out. Thus, the amount of biomass burned for heating purposes  $Vb_{dpt}^{Dr}$  has to be discretized, too. This is implemented by defining a certain number of discretization points  $Nbv_d^{Dr}$ . Applying this number and the upper bound  $Vb_{d,max}^{Dr}$ , biomass volume values  $VB_{dv}^{Dr}$  are calculated in the model.

Due to the linear dependency of biomass density on moisture content, the amount of water evaporated (equals the density change) does not decrease at low moisture levels. Thus, a moisture reduction corresponding to  $MCstep_d^{Dr}$  always corresponds to the same amount of water  $Wevap_{dp}^{Dr}$ .

$$\begin{aligned} Wevap_{dp}^{Dr} &= D_p^{zero} (1 + MCi_d^{Dr}) - D_p^{zero} (1 + MCi_d^{Dr} - MCstep_d^{Dr}) \\ &= D_p^{zero} MCstep_d^{Dr} \end{aligned} \quad (10)$$

$$\forall d \in Dryers, p \in Products$$

To be able to consider a decreasing drying rate nevertheless, a modifying factor has been implemented in the calculation of the specific drying energy  $\sigma_{dlp}^{Dr}$  given in Eq. (11). By means of



this factor, the specific evaporation energy  $q_{dp}^{Dr}$  linearly increases at low drying moisture levels.

$$\sigma_{dtp}^{Dr} = Wevap_{dp}^{Dr} \sum_{i \text{ in Index}} q_{dp}^{Dr} \left( 1 + MCI_d^{Dr} - \left( MCI_{dl}^{Dr} - (i-1)MCstep_d^{Dr} \right) \right) \quad (11)$$

$$\forall d \in \text{Dryers}, l \in \text{Pairs}, p \in \text{Products}$$

Table 2 gives a numerical example of the modification of  $q_{dp}^{Dr}$  implemented in the calculation of the specific drying energy  $\sigma_{dtp}^{Dr}$ .

To maintain a linear mixed integer problem, both the input and output moisture content has to be further restricted. This is done by applying the predefined discretization moisture pairs. The binary variable  $\lambda_{dlvt}^{Dr}$  is implemented to select the most suitable moisture pair. The values of  $\lambda_{dlvt}^{Dr}$  are set by the solver. The constraint given by

$$\sum_{l \in \text{Pairs}, v \in \text{Burn}} \lambda_{dlvt}^{Dr} = 1 \quad (12)$$

$$\forall d \in \text{Dryers}, t \in \text{Time\_steps}$$

assures that only one  $\lambda_{dlvt}^{Dr}$  is set to equal one. Thus, only one moisture pair (the most appropriate one) is chosen. This choice is taken by the solver considering the other constraints and the cost functions.

Eq. (13) and (14) restrict the difference between input and output moisture (the level of moisture reduction in the dryer), applying the combinations given by the moisture discretization pairs.

$$MCin_{dpt}^{Dr} \leq \sum_{l \in \text{Pairs}, v \in \text{Burn}} MCI_{dl}^{Dr} \lambda_{dlvt}^{Dr} \quad (13)$$

$$MCout_{dpt}^{Dr} \geq \sum_{l \in Pairs, v \in Burn} MCO_{dl}^{Dr} \lambda_{dvt}^{Dr} \quad (14)$$

$$\forall d \in Dryers, l \in Pairs, p \in Products, t \in Time\_steps$$

In the same way as the moisture level, the amount of biomass burned has to be restricted by applying the discretized values  $VB_{dv}^{Dr}$  and the binary variable  $\lambda_{dvt}^{Dr}$ .

$$Vb_{dpt}^{Dr} = \sum_{l \in Pairs, v \in Burn} VB_{dv}^{Dr} \lambda_{dvt}^{Dr} \quad (15)$$

$$\forall d \in Dryers, p \in Products, t \in Time\_steps.$$

The energy required to reduce the biomass moisture in the dryer is calculated by means of the specific drying energy  $\sigma_{dlp}^{Dr}$  and given by

$$Q_{dpt}^{Dr} \geq \sigma_{dlp}^{Dr} Vin_{dpt}^{Dr} - (1 - \sum_{v \in Burn} \lambda_{dvt}^{Dr}) \sigma_{dlp}^{Dr} V \max_{dp}^{Dr} \quad (16)$$

$$\forall d \in Dryers, l \in Pairs, p \in Products, t \in Time\_steps.$$

The heat required to dry the biomass volume can either be supplied by an external heat source or by burning biomass or oil. The heating value  $HVin_{dlp}^{Dr}$  of the biomass input volume is calculated applying the dependency described in chapter 3.2, subject to the moisture pairs given for discretization. The amount of drying heat can not exceed the drying heat capacity of the dryer:

$$Q_{dpt}^{Dr} \leq Qex_{dt}^{Dr} + F_{dpt}^{Dr} HVoil + \sum_{l \in Pairs, v \in Burn} VB_{dv}^{Dr} HVin_{dlp}^{Dr} \lambda_{dvt}^{Dr} \quad (17)$$

where

$$Q_{dpt}^{Dr} \leq Q \max_{dp}^{Dr} \quad (18)$$

$$\forall d \in Dryers, p \in Products, t \in Time\_steps$$

It is assumed that some of the biomass gets lost or becomes unusable during the drying process. This is modeled by defining a certain percentage of the input volume as loss volume (Eq. 19). Furthermore, the input volume can not exceed the maximum input capacity (Eq. 20):

$$Vin_{dpt}^{Dr} = Vout_{dpt}^{Dr} (1 + \varepsilon_{dp}^{Dr}) \quad (19)$$

where

$$Vin_{dpt}^{Dr} \leq V \max_{dp}^{Dr} \quad (20)$$

$$\forall d \in Dryers, p \in Products, t \in Time\_steps$$

The operating costs of the dryer model are energy costs which are calculated in the supply models. Fuel costs due to oil use  $F_{dpt}^{Dr}$ , external heat use  $Qex_{dt}^{Dr}$  or the cost for the biomass burned in the dryer are accounted for in the oil supply, the external heat supply and the biomass supply model object function, respectively. An oil-fired dryer causes emission, and the emission costs are calculated as given in Eq. (21), provided that an emission penalty  $Pen_{de}^{Em}$  is defined.

$$C^{Dr} = \sum_{e \in Emission} \sum_{t \in Time\_steps} \sum_{d \in Dryers} Pen_{de}^{Em} Emit_{edt} \quad (21)$$

where

$$Emit_{edt} = em_{de} F_{dpt}^{Dr} HVoil \quad (22)$$

$$\forall p \in Products, d \in Dryers, t \in Time\_steps, e \in Emissions .$$

The amount of biomass flowing to the dryer is the sum of the biomass volume dried and the (optional) biomass volume burned to supply drying heat. The biomass is fed to the dryer from the biomass node  $n$  connected to the dryer input point  $i$ . The input and output volume is linked by Eq. (19). The dried biomass is sent to the biomass node  $n$  connected to the dryer output point  $j$ :

$$Vin_{dpt}^{Dr} + Vb_{dpt}^{Dr} = \sum_{i:(n,i) \in Net2net} V_{nipt}^{N2N} \quad (23)$$

$$Vout_{dpt}^{Dr} = \sum_{j:(j,n) \in Net2net} V_{jnpt}^{N2N} \quad (24)$$

$$\forall d \in Dryers, n \in BioNodes, p \in Products, t \in Time\_steps$$

The biomass moisture content at the dryer inlet (outlet) is set equal to the moisture content in the biomass node connected to the dryer inlet (outlet). This is done applying the general node structure and the set “Net2net”.

$$MCin_{dpt}^{Dr} = \text{if } n \in BioNodes \text{ then } MC_{npt}^{No} \quad (25)$$

$$\forall d \in Dryers, (n,d) \in Net2net, p \in Products, t \in Time\_steps$$

$$MCout_{dpt}^{Dr} = \text{if } n \in BioNodes \text{ then } MC_{npt}^{No} \quad (26)$$

$$\forall d \in Dryers, (d,n) \in Net2net, p \in Products, t \in Time\_steps$$

In addition to the heat obtained by burning biomass in the dryer, it is possible to reuse external waste heat or to produce drying heat from burning oil. The energy balance for the dryer heat input point  $h$  and the dryer fuel input point  $f$  is

$$Qex_{dt}^{Dr} = \sum_{h:(i,h) \in Net2net} P_{iht}^{N2N} + \sum_{h:(s,h) \in Supply2net} P_{sh}^{Sup} \quad (27)$$

$$F_{dpt}^{Dr} HVoil = \sum_{f:(i,f) \in Net2net} P_{ift}^{N2N} + \sum_{f:(s,f) \in Supply2net} P_{sft}^{Sup} \quad (28)$$

$$\forall d \in Dryers, t \in Time\_steps .$$

Here, the common energy flow variables are used, since no information on biomass quality is required. The biomass chain thus interacts directly with the other energy carriers in the system.

### 3.4 Storage model

Any biomass product can be sent to the storage model. In addition to the energy storage function, the model provides the opportunity to indicate passive drying effects as a function of the storage time. The passive drying function is not appropriate for an hourly time resolution, but it becomes applicable when the analysis is carried out on a weekly basis as described in Section 3. However, the passive drying functionality is defined per timestep and is not limited to a certain time resolution. To indicate internal fuel use due to biomass handling in the storage, a fuel input point is also defined.

The drying rate  $\delta_{sp}^{St}$  is user-defined and describes the reduction of biomass moisture (percentage) which can be achieved per timestep. In addition to the moisture reduction coefficient, the volume loss coefficient  $\varepsilon_{sp}^{St}$  and the storage cost coefficient  $c_s^{St}$  are also defined per timestep.

Similarly to the drying model, the moisture reduction coefficient is treated as an average input value. However, in contrast to the dryer model, the decreasing drying rate at lower moisture levels is not implemented. It is assumed that the moisture reduction rate decreases with increasing storage time  $T_{out_{sb}}^{St} - T_{in_{sa}}^{St}$ , expressed in parameter  $\Delta_{spab}^{St}$ . The volume loss coefficient is dealt with in the same way: The volume losses are increasing with increasing storage time, expressed in the calculated parameter  $E_{spab}^{St}$ . In this way, volume and quality losses due to long term storage can be indicated. The storage cost is defined per timestep, too, but the cost is assumed as constant and summed up over the total storage time in the parameter  $C_{sab}^{St}$ . That means that no cost increase due to increasing storage time is implemented.

The binary variable  $\lambda_{spab}^{St}$  keeps track of how long (how many timesteps) the biomass at least has to be stored to reach the moisture level required at the storage output. It is not possible to take out biomass with a moisture level higher than that one required at the storage output point.

It is assumed that increasing storage time has an impact on both the moisture reduction coefficient  $\delta_{sp}^{St}$  and the volume loss coefficient  $\varepsilon_{sp}^{St}$ . The storage costs are assumed to be stable, thus they do not change with increasing storage time and are constant in each timestep. The total storage costs are calculated by multiplying the cost coefficient by the number of timesteps spent between input and output of biomass to/from storage ( $Tout_{sb}^{St} - Tin_{sb}^{St}$ ) given by

$$C_{sab}^{St} = \begin{cases} \text{if } Tin_{sa}^{St} = Tout_{sb}^{St} \text{ then } 0 \\ \text{else } c_s^{St} (Tout_{sb}^{St} - Tin_{sb}^{St}) \end{cases} \quad (29)$$

$$\forall s \in Storages, ab \in Time\_steps$$

Another assumption is that the longer the biomass is stored, the more volume gets lost (due to biomass handling). In addition to handling losses, other negative effects may appear (quality loss due to e.g. fungal decay). These effects are modeled by defining a volume loss parameter dependent on storage time:

$$E_{spab}^{St} = \begin{cases} \text{if } Tin_{sa}^{St} = Tout_{sb}^{St} \text{ then } 1 \\ \text{else } (1 - \varepsilon_{sb}^{St})^{(Tout_{sb}^{St} - Tin_{sb}^{St})} \end{cases} \quad (30)$$

$$\forall s \in Storages, p \in Products, ab \in Time\_steps$$

An increasing time difference between biomass input and output of the same volume leads to growing volume losses. The equation implemented to express a decreasing drying rate is comparable to the volume loss calculation in Eq. (30). The mode of calculation of both factors is based on assumptions. It is assumed that less moisture is evaporated when the biomass already has been stored for a long time. This offers the possibility to display the decelerated drying effect at lower moisture levels in the model. Contrary to the volume loss calculation, the decreasing drying rate is still defined per timestep, given by

$$\Delta_{spab}^{St} = \begin{cases} \text{if } Tin_{sa}^{St} = Tout_{sb}^{St} \text{ then } \delta_{sp}^{St} \\ \text{else } \frac{1 - (1 - \delta_{sp}^{St})^{(Tout_{sb}^{St} - Tin_{sa}^{St})}}{Tout_{sb}^{St} - Tin_{sa}^{St}} \end{cases} \quad (31)$$

$$\forall s \in Storages, p \in Products, ab \in Time\_steps .$$

Table 3 gives a numerical example of the calculation of both the time-dependent parameters

$\Delta_{spab}^{St}$  and  $E_{spab}^{St}$  and the constant cost parameter  $C_{sab}^{St}$  in the storage model.

The user defines whether passive drying effects occur during storage or not. This is done by implementing the binary parameter  $\alpha_{sp}^{St}$ . If  $\alpha_{sp}^{St}$  is set to zero (no passive drying in storage), the storage time is not restricted. That means that the optimization algorithm chooses freely (only restricted by the storage cost in the objective function) for how many timesteps the biomass is stored and when it is sent to the next biomass model in the supply chain. However, if  $\alpha_{sp}^{St}$  is set to one (passive drying effects in storage), time dependent restrictions have to be met. In this case, the storage time is restricted applying the binary variable  $\lambda_{spab}^{St}$ . Considering the maximum and minimum values of moisture content given in the biomass node at the storage output or the demand moisture level in the end of the supply chain, a certain moisture range for the storage output moisture level is defined. Applying the binary variable  $\lambda_{spab}^{St}$  and the drying rate  $\Delta_{spab}^{St}$ , it is calculated how many timesteps the biomass has to be stored to reach the output moisture level required:

$$2N^T \lambda_{spab}^{St} \geq (Tout_{sb}^{St} - Tin_{sa}^{St}) - \frac{MCin_{spt}^{St} - MCout_{spt}^{St}}{\Delta_{spab}^{St}} \quad (32)$$

$$2N^T (\lambda_{spab}^{St} - 1) \leq (Tout_{sb}^{St} - Tin_{sa}^{St}) - \frac{MCin_{spt}^{St} - MCout_{spt}^{St}}{\Delta_{spab}^{St}} \quad (33)$$

$$\forall s \in Storages, p \in Products, ab \in Time\_steps .$$

$\lambda_{spab}^{St}$  is set to one if the output moisture level can be reached during the time period

$Tin_{sa}^{St} - Tout_{sa}^{St}$ , otherwise it is set to zero. It is assumed that some of the biomass gets lost or becomes unusable during the storage process. This is modeled by defining a certain percentage of the input volume as loss volume. The biomass volume flow to and from storage is restricted by

$$Vin_{spt}^{St} = \sum_{b \in Time\_steps} Vtrans_{spab}^{St} \quad (34)$$

$$Vout_{spt}^{St} = \sum_{a \in Time\_steps} Vtrans_{spab}^{St} E_{spab}^{St} \quad (35)$$

where

$$Vtrans_{spab}^{St} \leq \lambda_{spab}^{St} V \max_s^{St} \quad (36)$$

$$\forall s \in Storages, p \in Products, ab \in Time\_steps,$$

where the volume loss factor  $E_{spab}^{St}$  is defined in Eq. (30).

The user-defined cost factor is multiplied by the biomass volume  $Vtrans_{spab}^{St}$  handled in storage to determine the storage cost:

$$C^{St} = \sum_{a,b \in Time\_steps} \sum_{s \in Storages} \sum_{p \in Products} C_{sab}^{St} Vtrans_{spab}^{St} + \sum_{e \in Emissions} Pen_{se}^{Em} Emit_{est} \quad (37)$$

where

$$Emit_{est} = em_{se} F_s^{St} HVoil \cdot Vin_{spt}^{St} \quad (38)$$

$$\forall p \in Products, s \in Storages, a,b \in Time\_steps, e \in Emissions$$

Storage keeping causes emissions only when an external fuel demand is defined, applying the parameter  $F_s^{St}$ . In this case, the emission costs are added to the operating costs, provided that an emission penalty  $Pen_{se}^{Em}$  is defined. Fuel costs are accounted for in the oil supply model objective.



The biomass is fed to the storage from the biomass node  $n$  connected to the storage input point  $i$  and sent from the storage to the biomass node  $n$  connected to the storage output point  $j$

$$Vin_{spt}^{St} = \sum_{i:(n,i) \in Net2net} V_{nipt}^{N2N} \quad (39)$$

$$Vout_{spt}^{St} = \sum_{j:(j,n) \in Net2net} V_{jnpt}^{N2N} \quad (40)$$

$$\forall s \in Storages, n \in BioNodes, p \in Products, t \in Time\_steps ,$$

applying the biomass flow variable  $V_{jnpt}^{N2N}$  ( $Bio\_net2net\_flow_{ijpt}$ ). The input and output volume is linked by Eq. (34) and (35). Similarly to the dryer model with Eq. (25) and (26), the biomass moisture content at the storage inlet (outlet) is set equal to the moisture content in the biomass node connected to the storage inlet (outlet):

$$MCin_{spt}^{St} = \text{if } n \in BioNodes \text{ then } MC_{npt}^{No} \quad (41)$$

$$\forall s \in Storages, (n,s) \in Net2net, p \in Products, t \in Time\_steps$$

$$MCout_{spt}^{St} = \text{if } n \in BioNodes \text{ then } MC_{npt}^{No} \quad (42)$$

$$\forall s \in Storages, (s,n) \in Net2net, p \in Products, t \in Time\_steps .$$

The fuel needed by the storage to handle the biomass is fed from the network to the storage fuel input point  $f$ .

$$F_s^{St} HVoil \cdot Vin_{spt}^{St} = \sum_{f:(i,f) \in Net2net} P_{ift}^{N2N} + \sum_{f:(s,f) \in Supply2net} P_{sft}^{Sup} \quad (43)$$

$$\forall d \in Storages, t \in Time\_steps$$

According to Eq. (28) in the dryer model, the common energy flow variables are used, since no information on biomass quality parameters is required.

## 4 CASE STUDY

To demonstrate the use of the new biomass models, especially the functionality of the active and passive drying processes in the *Dryer* and *Storage* model, a simple case study is carried out. The main intention is to point out the properties and functionality of the new models rather than to represent a detailed analysis of a real biomass supply chain with several alternatives. Therefore, no investment analysis is carried out and the emissions caused by the different processes applied in the case are not investigated. Only limited focus has been given to obtain realistic input data.

### 4.1 Case overview

The analysis is run over a time period of twelve weeks (twelve timesteps  $t$ ). This period is appropriate to describe the active drying processes in the dryer and to allow for moisture decrease from one week to another in the storage model.

It is assumed that the amount of biomass products available within a time period of twelve weeks varies. Thus, the biomass supply profile is not constant, but the biomass demand profile is assumed to be constant. Hence, storage keeping is required to be able to cover the demand in all weeks. The combination of moisture content demanded at different points in the case is set in such a way that both passive and active drying processes are possible.

The case setup is shown in Fig. 3. Three different biomass products are handled in the case: spruce, chips and pellets with the reference values given in Table 4. On the demand site, there is a biomass load point demanding chips at a constant level of  $100 \text{ m}^3/\text{week}$  (average  $0.6 \text{ m}^3/\text{h}$ ) and a heat load point with a demand of  $20 \text{ MWh}/\text{week}$  (average  $119 \text{ kWh}/\text{h}$ ). To cover the demand,

two different biomass supplies with restricted capacities are available: a chip supply (45 USD/m<sup>3</sup>) and a spruce supply (35 USD/m<sup>3</sup>). As can be seen from Fig. 4, the chip supply volume is not sufficient to cover the chip demand. Thus, chips have to be processed from spruce in the chipper before they are sent to storage. This increases the price (spruce) due to the additional energy costs generated in the chipper.

The moisture content required in the different supply, conversion and load points is indicated in the case setup in Fig. 3. Both the chips and the spruce are supplied with a moisture content of 50 %wt. The moisture content demanded by the biomass load (chips) is 11 %wt while the moisture content of the biomass burned in the boiler can not exceed 10 %wt. Thus, drying is required. This can be carried out either active in the dryer or passive in the storages. In both storage models, the drying option is enabled and it is assumed that the moisture content of the biomass stored is reduced with 1 %wt during one week. The specific energy required in the dryer to evaporate one kg of water from biomass is set to 2 kWh/kg (average heat requirement for dryers [19]).

After having passed the dryer, the main fraction of chips is sent to the biomass demand point. The remaining chips are sent to a second storage which is followed by a combination of a pellets production plant and a boiler to cover the heat demand. The drying heat required in the dryer is supplied both by an external heat source (restricted capacity) and by burning fuel. The option of burning biomass is not used. The heat required in the pellet production plant is covered by an external heat source, too. Both the pellet plant and the boiler demand electricity to run internal control systems and other supplementary devices. The amount of energy required to handle the biomass inside storage is neglected. Similarly, no additional operating costs are defined.

Apart from the combustion model, the maximum capacity (volume and heat) in the conversion models is not restricted. In the combustion model, the maximum volume capacity is limited so

that the integrated additional oil firing option has to be applied. The volume losses are set to 1 % of the input volume in the storage and the dryer model, while losses of 5 % are assumed in the chipper and the pellet plant. There is no cost associated with the use of external heat. The fuel cost is set to 0.65 USD/liter, the electricity cost to 84 USD/MWh.

## 4.2 System operation and results

The model chooses from the two supply sources available as shown in Fig. 5. The volume capacity of the spruce supply is utilized fully while the chips supply only is used to cover lacking chips production. With the cost combination defined in the model, it is more profitable to process chips from spruce and to pay for the fuel required in the process than to purchase chips directly from supply.

Fig. 6 illustrates both the drying effect and the storage keeping in storage I. The moisture content is reduced from 50 %wt at the storage input to values in the range between 46.4 %wt and 42.3 %wt. The lowest output moisture content is reached in week four. One has to keep in mind that the set *Time\_steps* is defined as circular. Thus, week twelve is followed by week one in the model. A certain amount of biomass sent to storage in week seven for instance might be sent out in week four. This leads to a storage time of nine weeks associated with a fairly high moisture reduction. As can be seen from Fig. 6 (a) and (c) the storage is filled to a high level to take advantage of the increasing moisture reduction with longer storage time.

In storage II, the moisture content of the chips is reduced from 11 %wt (dryer output) to 10 %wt (boiler input required). With the moisture reduction factor of 1 %wt assumed in storage II, the requested moisture level can be reached during one week. Thus, chips sent to storage in one week are sent out with a moisture level of 10 %wt in the following week. Therefore, in contrast to storage I, no remarkable storage effects are to be observed in storage II.

The objective value represents the operating cost for the whole system. Over a time horizon of twelve weeks the operating cost adds up to 68,733.51 USD. This value represents the fuel cost, the biomass cost and the electricity cost.

## **5 DISCUSSION**

The objective of the present work is to develop a linear modeling framework as a part of the eTransport optimization tool that can be applied to most relevant components in a biomass supply chain, including sources, handling/processing, storage and end use. The moisture content has large influence on the efficiency of various biomass conversion processes like combustion and pyrolysis [20]. Thus, the main focus of this work has been to represent the relationship between moisture and energy content of different kinds of biomass and to handle long-term processes in the optimization like passive drying effects.

With the modeling approach presented in this paper, a solid basis for the linear modeling of general biomass supply chains has been developed. Due to assumptions and simplifications made in the models as well as the fact that the biomass module is embedded in the already existing eTransport framework, there are some model limitations.

The modeling of long-term effects in the biomass module is a new approach which is partly limited by the time structure in eTransport. Long-term effects in the biomass models can be a challenge when combined with shorter time resolution e.g. in heat and electricity loads. In the case study presented this has been solved by using weekly average values.

Another time aspect in the model is the solving time. It varies with the complexity of the problem depending on system size, the range of products to be handled and the number of time steps chosen. One possibility to avoid prohibitive solving times is to lower the precision of the solver. This can be justified by the fact that uncertainty in the input dataset contributes

significantly more to the total uncertainty of the objective value than the gap between the best feasible solution and its lower bound. To illustrate this, the case presented has been solved with a range of allowed gaps in the CPLEX branch and bound algorithm. The resulting solving time and objective values are given in Table 5. As seen from the table the solution time is reduced by a factor of 100 by increasing the allowed gap from 5 % to 10 % of lower bound on the objective value.

The economic part of the biomass model application and the emission handling are not discussed in detail since the calculation follows the main eTransport algorithms documented in [14]. Emissions can be accounted for both in biomass sources (due to harvesting, handling, etc. ), energy use in biomass processing models and from combustion. These emissions are then considered by the investment algorithm in the same way as for other combustion models.

In the case study, only limited focus has been given to obtain realistic input data. The main objective with the case study is to demonstrate the functionality of the new methodology presented. The assembly of models shown in the case study represents one possibility out of an unlimited number of combinations. With the data chosen, the functionality available in the biomass models is demonstrated. A next step in the model development and improvement would be to validate the results with working conditions of a real system.

## **6 SUMMARY**

Both the eTransport model and the biomass module discussed in this paper are still under development. The biomass models are partly an expansion of models from a master thesis [18]. The work presented in this paper has been carried out with financial support from the Research Council of Norway and StatoilHydro. Requirements from StatoilHydro have influenced the technologies to be modeled. In addition to the seven biomass models presented in Section 3, two more models have been developed:

*Transport:* Truck transport. Discrete model, emissions due to fuel use.

*Pyrolysis:* Bio oil production in a fast pyrolysis process. Link to bio fuel applications.

These two models are not discussed in detail, but they illustrate the many possibilities for further development of the biomass module. The transport model is a discrete model. The pyrolysis model can be seen as a link to bio fuel applications. This link shows the wide variety of biomass utilization. Other processing technologies as for instance bundling and grinding could be implemented in future. Moisture dependent efficiency of biomass combustion models can also be implemented within the new framework. The whole biomass sector itself is under development and new and more improved technologies frequently appear. With its flexible structure, the biomass module presented here is a solid basis for further development and improvement.

## **7 ACKNOWLEDGEMENTS**

The authors gratefully acknowledge the support from the Research Council of Norway and from StatoilHydro as a sponsor of the project.

## 8 REFERENCES

- [1] International Energy Agency. IEA Bioenergy – an international collaboration in Bioenergy. See also: <http://www.ieabioenergy.com> (accessed 2009-02-01)
- [2] European Union Energy Research – Biomass. See also: [http://ec.europa.eu/research/energy/nn/nn\\_rt/nn\\_rt\\_bm/article\\_1110\\_en.htm](http://ec.europa.eu/research/energy/nn/nn_rt/nn_rt_bm/article_1110_en.htm) (accessed 2009-02-01)
- [3] Sokhansanj S, Kumar A, Turhollow AF. Development and implementation of integrated biomass supply analysis and logistics model (IBSAL). *Biomass and Bioenergy* 2006; 30:838-847
- [4] Freppaz D, Minciardi R, Robba M, Rovatti M, Sacile R, Taramasso A. Optimizing forest biomass exploitation for energy supply on a regional level. *Biomass and Bioenergy* 2004; 26:15-25.
- [5] Gigler JK, Hendrix EMT, Heesen RA, van den Hazelkamp VGW, Meerdink G. On optimization of agri chains by dynamic programming. *European Journal of Operational Research* 2002; 139:613-625.
- [6] Frombo F, Minciardi R, Robba M, Sacile R. A decision support system for planning biomass-based energy production. *Energy* 2009; 34:362-369.
- [7] Kumar A, Sokhansanj S, Flynn PC. Development of a multicriteria assessment model for ranking biomass feedstock collection and transportation systems. *Applied Biochemistry and Biotechnology* 2006; 123:71-87.
- [8] Nagel J. Determination of an economic energy supply structure based on biomass using a mixed-integer linear optimization model. *Ecological Engineering* 2000; 16:91-102.
- [9] Rentizelas AA, Tolis AJ, Tatsiopoulou IP. Logistics issues of biomass: The storage problem and the multi-biomass supply chain. *Renewable and Sustainable Energy Reviews* 2009; 13:887-894.



- [10] Mahmoudi M, Sowlati T, Sokhansanj S. Logistics of supplying biomass from a mountain pine beetle-infested forest to a power plant in British Columbia. *Scandinavian Journal of Forest Research* 2009; 24: 76-86.
- [11] Bakken BH, Wolfgang O, Roynstrand J, Frydenlund F, Skjelbred HI. eTransport: a novel tool for energy system planning, report A6255. Trondheim, SINTEF Energy Research, Norway, 2006, ISBN 82-594-2966-7.
- [12] Bakken BH, Holen AT. Energy service systems: integrated planning case studies. In: *Proceedings of the IEEE Power Engineering Society 2004 general meeting, Denver, CO, USA, 2004*. IEEE 2004.
- [13] Bakken BH, Velken, I. Linear Models for Optimization of Infrastructure for CO<sub>2</sub> Capture and Storage. *IEEE Transactions on energy conversion* 2008; 23:824-833.
- [14] Bakken BH, Wolfgang O, Skjelbred HI. eTransport: Investment planning in energy supply systems with multiple energy carriers. *Energy* 2007; 32:1676–1689.
- [15] Fourer R, Gay DA, Kerningham BW. *AMPL: A Modeling Language for Mathematical Programming*. Toronto: Thomson, 2003.
- [16] Tomasgard A, Bjørndal M, Midthun K. Modeling optimal economic dispatch and flow externalities in natural gas networks. In: *Proceedings of the Trans-Atlantic Infraday, Conference on applied infrastructure modeling and policy analysis, Maryland, USA, 2007*.
- [17] Midthun K. Optimization models for liberalized natural gas markets. Doctoral thesis, Norwegian University of Science and Technology, Trondheim, Norway, 2007, ISBN 978-82-471-4526-5.
- [18] Li Y. Modelling of infrastructure for biomass collection. Master thesis, Norwegian University of Science and Technology, Trondheim, Norway, 2006.
- [19] Amos WA. Report on Biomass Drying Technology, report NREL/TP-570-25885. National Renewable Energy Laboratory, 1617 Cole Boulevard, Golden, CO, USA, 1998.

- [20] Yoshida Y, Dowaki K, Matsumura Y, Matsubishi R, Li D, Ishitani H, Komiyama H. Comprehensive comparison of efficiency and CO<sub>2</sub> emissions between biomass energy conversion technologies - position of supercritical water gasification in biomass technologies. *Biomass and Bioenergy* 2003; 25: 257–272.

## FIGURE CAPTIONS

Fig. 1 Biomass models in eTransport – symbolic pictures

Fig. 2 Relation between moisture content and EHV [kWh/m<sup>3</sup>]

Fig. 3 Biomass case in eTransport

Fig. 4 Maximum volume capacity spruce and chips supply

Fig. 5 Total output volume spruce and chips supply

Fig. 6 Storage I, (a) Input and output volume, (b) Moisture content, (c) Volume stored

---

*Parameter Data*

---

$$MCi_d^{Dr} = 0.6$$

$$MCo_d^{Dr} = 0.4$$

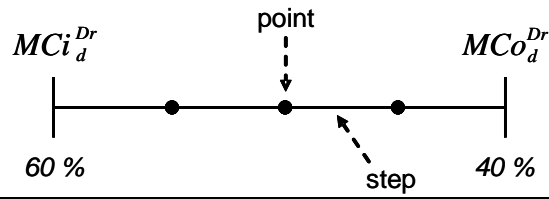
$$Nli_d^{Dr} = 3$$

$$Nsteps_d^{Dr} = 4$$

$$Npairs_d^{Dr} = 15$$

$$MCstep_d^{Dr} = \left( MCi_d^{Dr} - MCo_d^{Dr} \right) / Nsteps_d^{Dr} = 0.05$$


---




---

*Generated moisture pairs*

---

(0.60/0.60)	(0.60/0.55)	(0.60/0.50)	(0.60/0.45)	(0.60/0.40)
	(0.55/0.55)	(0.55/0.50)	(0.55/0.45)	(0.55/0.40)
		(0.50/0.50)	(0.50/0.45)	(0.50/0.40)
			(0.45/0.45)	(0.45/0.40)
				(0.40/0.40)

---

**Table 1 Example: Generation of moisture pairs for discretization in dryer model**

$MCI_d^{Dr}$	$MCo_d^{Dr}$	$q_{dp}^{Dr}, const$
0.6	0.2	2.0
$MCI_{dl}^{Dr}$	$MCO_{dl}^{Dr}$	$q_{dp}^{Dr}, mod$
0.6	0.5	2.0
0.6	0.4	2.1
0.6	0.3	2.2
0.6	0.2	2.3
0.5	0.4	2.2
0.5	0.3	2.3
0.5	0.2	2.4
0.4	0.3	2.4
0.4	0.2	2.5
0.3	0.2	2.6

**Table 2 Example: calculation of specific drying energy in dryer model**

	$\delta_{sp}^{St}$	$\epsilon_{sp}^{St}$	$C_s^{St}$
	0.05	0.01	200
$Tout_{sb}^{St} - Tin_{sa}^{St}$	$\Delta_{spab}^{St}$	$E_{spab}^{St}$	$C_{sab}^{St}$
1	0.0500	0.9900	200
2	0.0488	0.9801	400
3	0.0475	0.9703	600
4	0.0464	0.9606	800
5	0.0452	0.9510	1000

**Table 3 Example: calculation of constants in storage model**

Parameter	Unit	Spruce	Chips	Pellets
$MC_p^{ref}$	%wt	0	18	8
$D_p^{ref}$	kg/m <sup>3</sup>	405	340	700
$HV_p^{ref}$	kWh/m <sup>3</sup>	2155	1000	3200

**Table 4 Reference values of case products**

MIPGAP [% of lower bound on objective value]	Solving time [seconds]	Objective value [USD]
10	7.07	69,123.7003
9	7.83	69,123.7003
8	14.12	69,028.6076
7	37.86	68,910.7083
6	159.06	68,733.5117
5	747.70	68,733.5117
4	> 1 hour	

**Table 5: Solving time and objective value for a range of gap tolerances in the solver**



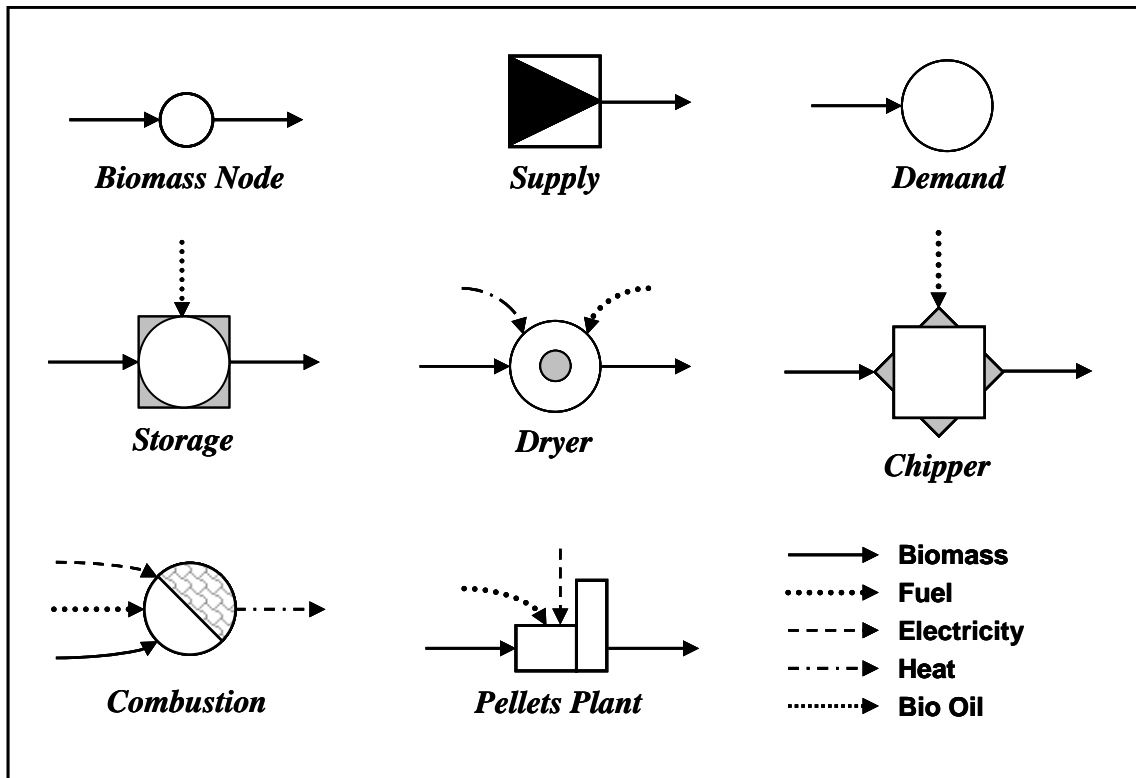
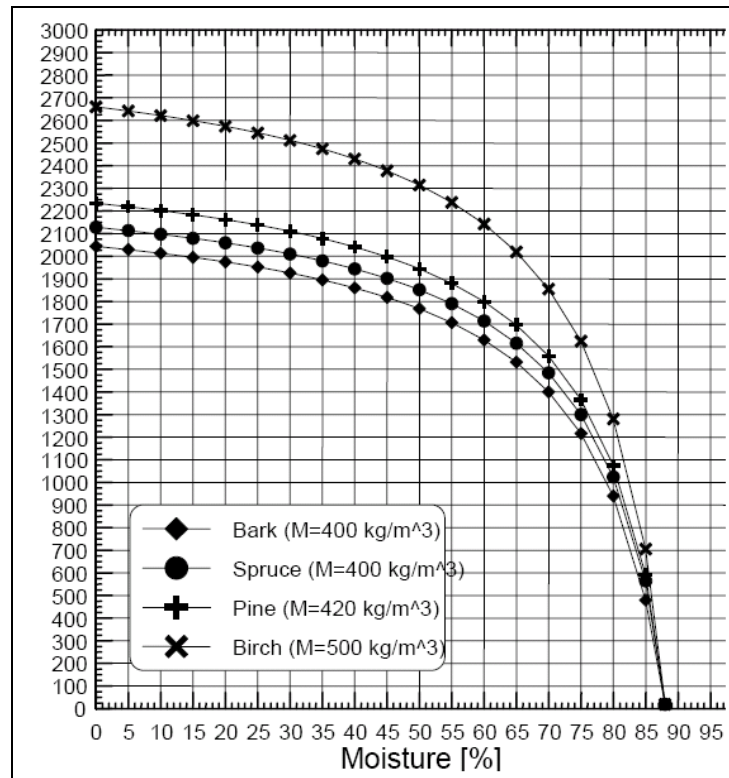
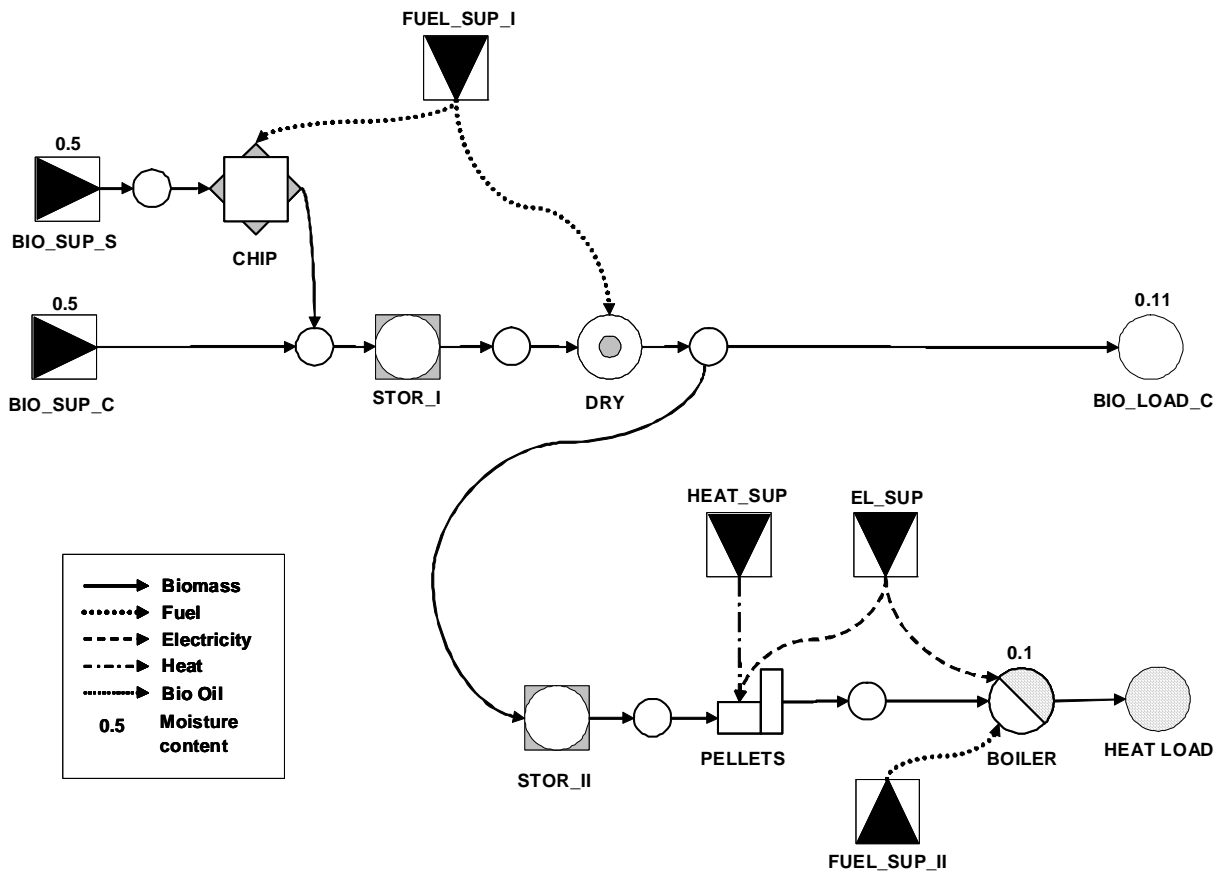


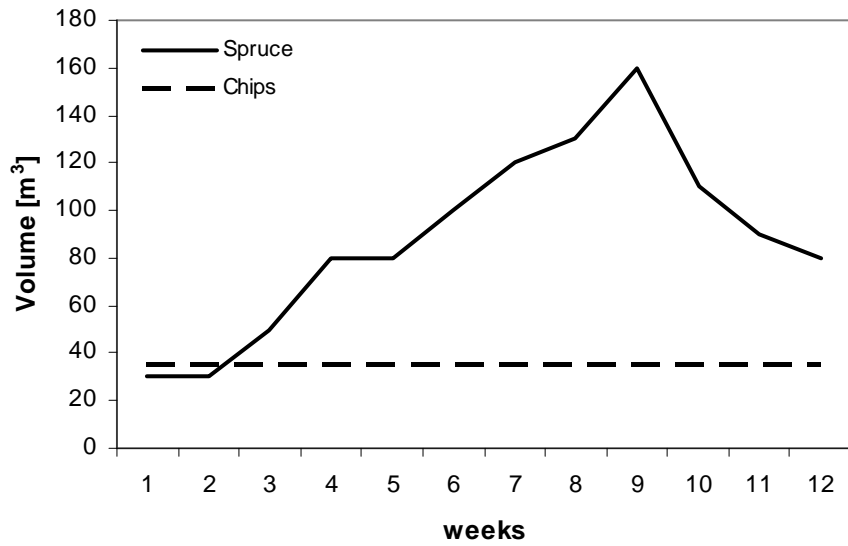
Fig. 1 Biomass models in eTransport – symbolic pictures



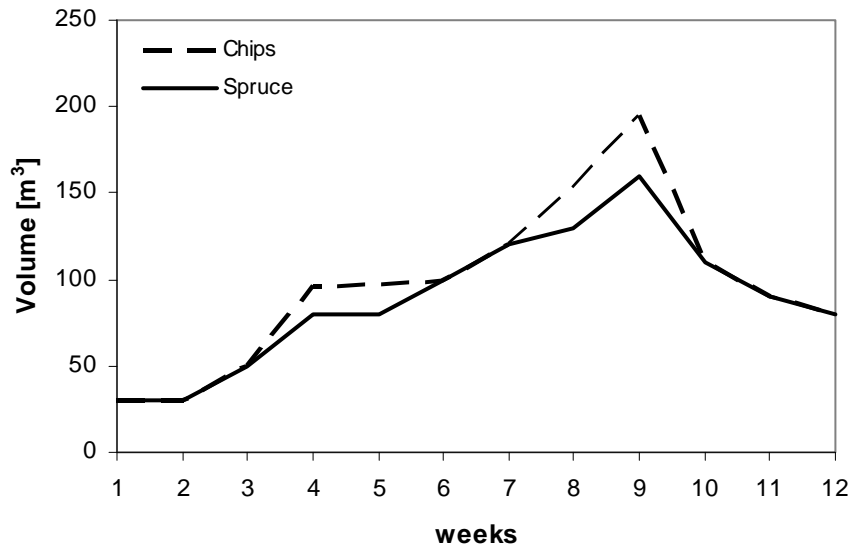
**Fig. 2 Relation between moisture content and EHV [kWh/m<sup>3</sup>]**



**Fig. 3 Biomass case in eTransport**

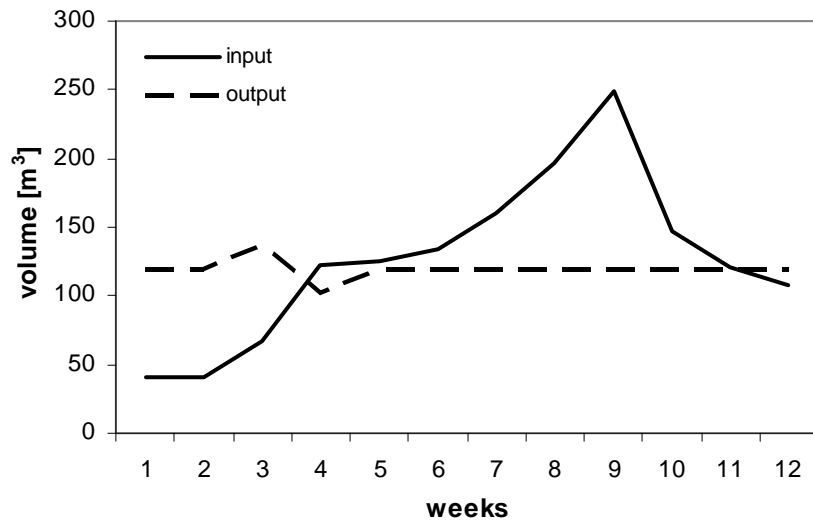


**Fig. 4 Maximum volume capacity spruce and chips supply**

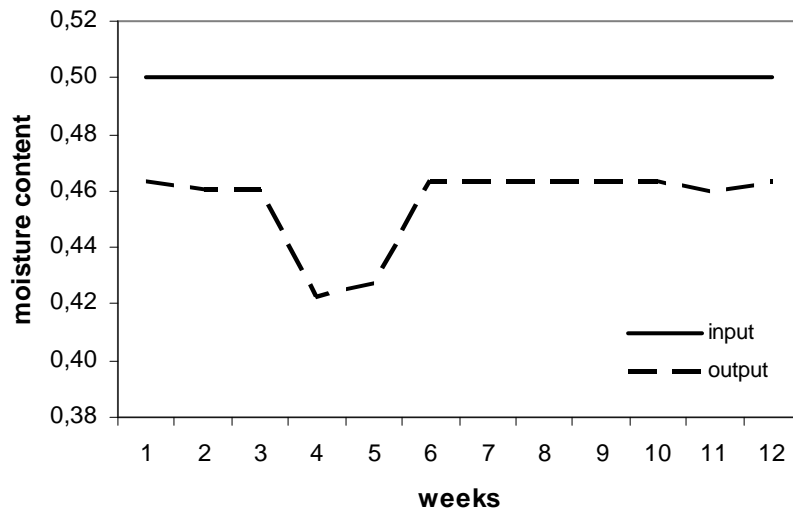


**Fig. 5 Total output volume spruce and chips supply**

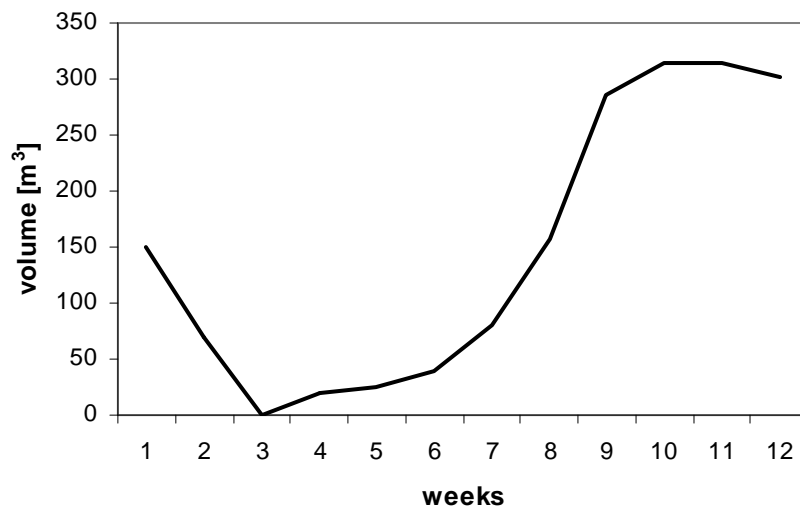
(a)



(b)



(c)



**Fig. 6 Storage I, (a) Input and output volume, (b) Moisture content, (c) Volume stored**