

# Active latent heat storage using biowax in a central heating system of a ZEB living lab

Alexis SEVAULT<sup>(a)</sup>, Erling NÆSS<sup>(b)</sup>

<sup>(a)</sup> SINTEF Energy Research

Postboks 4761 Torgarden, 7465 Trondheim, Norway, [Alexis.Sevault@sintef.no](mailto:Alexis.Sevault@sintef.no)

<sup>(b)</sup> NTNU Department of Energy and Process Engineering

Trondheim, 7491, Norway, [Erling.Nass@ntnu.no](mailto:Erling.Nass@ntnu.no)

## ABSTRACT

The Zero Emission Building (ZEB) lab in Trondheim (Norway), owned by SINTEF and NTNU, provides a structure to develop and test innovative solutions in a living laboratory. An innovative latent heat storage (LHS) unit using biowax as phase change material (PCM) has been integrated in the central water-based heating system. The LHS unit stores excess heat from the main heat pump and the district heating network. One challenge is to make use of the full potential of the PCM latent heat to have a compact and effective unit, while the unit itself should have a low associated CO<sub>2</sub>-footprint. The heat storage capacity is 194 kWh, corresponding to the heat needed on top of the heat pump to cover for 2-3 consecutive days in the coldest days, with a maximum combined heat output of 26 kW. Bio-based wax is used as PCM with melting temperature 37 °C and latent heat 198 kJ/kg.

Keywords: Phase Change Materials, PCM, Thermal Energy Storage, Heat Battery, Biowax, Central Heating System

## 1. INTRODUCTION

The ZEB Lab project ([www.zeblab.no](http://www.zeblab.no)), coordinated by SINTEF and NTNU, aims at building a ZEB (Zero Emission Building) in Trondheim (Norway) starting in 2019, to be used both as office building and living laboratory (Time et al. 2019). The building relies on innovative technologies, both regarding building materials and energy system. One technology to be implemented and tested in the central heating system of the building is a latent heat storage (LHS) unit using a phase change material (PCM).

The LHS unit is integrated in the low-temperature heating system centred around a heat pump providing hot water for space heating. An essential asset of the LHS unit is to be able to provide high heat storage capacity and heat output within the narrow temperature range offered by low-temperature heating. During hours of low heat demand, the LHS unit is able to store excess heat. During high demand, the stored heat is released either to provide heat directly to the heating circuit or to support the heat pump by compensating for a drop of return temperature below the optimal intake temperature. Since such LHS technology is not commercially available yet, an experimental unit has to be custom-designed following the best integration path in the heating system.

### 1.1. Objective

The main objectives of the present study are: (1) to assess the full integration of the LHS unit in the central heating system of the ZEB Laboratory; (2) to dimension the LHS unit according the building energy demand, while selecting the most appropriate PCM.

### 1.2. Literature review

A well-known challenge with using PCM for thermal energy storage (TES) is the poor thermal conductivity for available PCMs, limiting heat transfer rates (Shukla et al., 2008) (Sevault et al., 2019). Comprehensive work has been done to increase the heat transfer rates within LHS systems by utilizing heat transfer enhancement techniques in numerical investigations and in experimental setups. However, only a few full-scale active LHS systems are in operation, making it challenging to document the potential upsides of coupling a LHS system to a heat pump for peak shaving and heating purposes.

Hirmiz et al. (2019) studied the integration of LHS systems into heat pump systems to improve the demand side flexibility and, ideally, the strategy for the LHS system to cover the complete heat demand during peak periods. By utilizing a TRNSYS numerical model, it was concluded that a LHS system can completely offset peak heat demand periods within 2 to 6 hours, reducing peaks in the power grid. Through modelling and measurement data analysis, Jokiel et al. (2017) evaluated a LHS system installed to reduce the required chiller capacity for three ammonia chillers/heat pumps covering the base load for heating/cooling at the Bergen University College (Norway). A dynamic system model was developed using Modelica (2019) to better understand the dynamics of melting and solidification of the PCM. The model proved to correctly predict the measured data, within an acceptable accuracy, especially regarding the accumulated values of absorbed and released heat.

Bonamente et al. (2016) studied the potential for system optimization in an existing ground-source heat pump heating system by implementing a TES unit. Computational fluid dynamic calculations were carried out and validated against measured data using two TES solutions: one using water as storage medium, and the other using PCM. Results showed that the COP of the system was increased from 2.9 to 3.2 and 3.4 for, respectively, heating and cooling modes when using water as TES medium. By using a PCM, the system COP was increased to 4.13 and 5.89 for, respectively, heating and cooling modes. In addition, the total volume of the PCM thermal storage was 10 times more compact compared to the water tank system making it more suitable for indoor installation and use.

Shifting cooling load during simulated summer conditions was experimentally tested by Moreno et al. (2014) by coupling a TES system to a heat pump. Thermal behaviour for the TES system was evaluated for cold storage and for space cooling. Two different TES configurations were tested, one using water and the other using PCM. The latter configuration utilized macro-encapsulated PCM with a phase change temperature of 10 °C. It was concluded that PCM storage is to be favoured over water storage. With identical volumes, the PCM tank was able to store 35.5 % more cold energy on average compared to the water storage tank. Other results indicated that by increasing the heat transfer rate for the PCM storage, it could store 14.5 % more cold energy, while delivering an acceptable indoor temperature for a 20.65 % longer duration compared to the water storage.

## 2. INTEGRATION OF THE LHS UNIT

### 2.1. Central heating system

The building heating system is central and relies on a 26-kW heat pump system and several heat sources and heat sinks along the hot water heating circuit. The selected heat pump system is designed to provide a temperature lift on the hot side from 35 °C to 40 °C. Besides the heat pump, heat from the local district heating is used as heat source for the building, providing hot water at 47 °C. Throughout the heating circuit, preheating of domestic hot water, room radiators and heat exchangers providing heated air for ventilation are used as heat sinks to heat up the building. Additional components enabling research experiments in the different rooms of the buildings are also planned but constitute minor heat sinks and heat sources on the heating circuit and thus are out of the scope of the present study. Without the LHS unit, the heat pump is meant to cover the maximum heat demand of the building, calculated to ca. 26 kW, necessary to maintain all rooms in the building at a comfortable temperature on the coldest days of the year in Trondheim (Norway). Using the LHS unit to support peak heating demands, the size and nominal output of the heat pump can be significantly reduced, so that it operates more effectively. A constant heat output of 14 kW from the heat pump combined with a charged LHS unit of about 200 kWh would allow for a total heating output of 26 kW for up to 16 h.

### 2.2. LHS unit integration

The integration of the LHS unit as an active component of the central heating system enables thermal buffering to support the heat pump (see Figure 1). Depending on the heating demand in the building, the return temperature of the heating loop might be lower than 34 °C, and thus require additional power from the heat pump to sustain 40 °C as outlet temperature. Integrating the LHS unit downstream from the heat pump, with the option to circulate the return water through it or not, provides the opportunity to both charge and discharge the LHS unit, while smoothing the output demand from the heat pump. Charging the LHS unit occurs when the heating demand is low, using 40 °C as inlet temperature, as it is generated by the heat pump. Using a PCM with phase change temperature within 35-37 °C, return water at lower temperature than 34 °C can circulate

through the charged LHS unit and be heated up before entering the heat pump. Additionally, the LHS unit can be directly charged using the district heating loop providing hot water at 47 °C. The present system also includes a placeholder to integrate another LHS unit and allow for future research experiments using various heat exchanger designs and test the thermal performance of several PCMs.

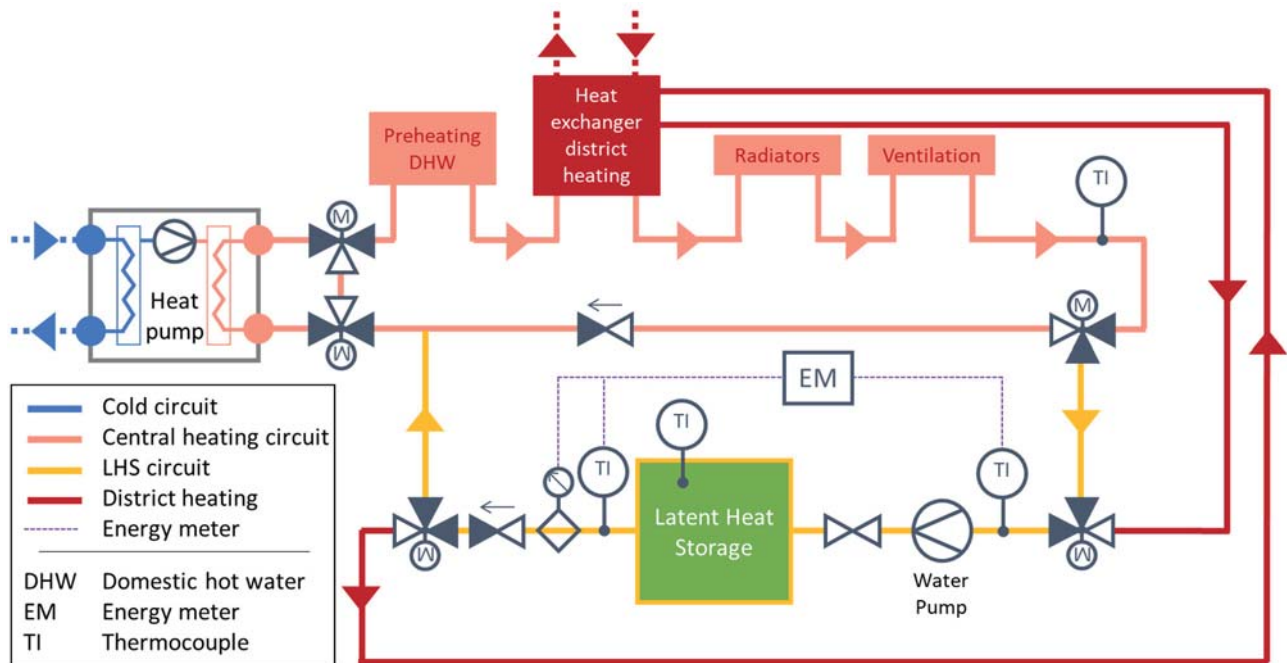

**Figure 1: Simplified process diagram of the central heating system focusing on the integration of the LHS unit. Only the instrumentation for control of the LHS unit is shown for simplification.**

Another feature available with this integration is the opportunity to use the LHS unit as a direct heat source in the building heating loop. This is meant to occur when the LHS unit is charged and the heating demand in the building is relatively low. Therefore, the heat pump can be bypassed, reducing significantly the energy use during these low-demand periods. This operational mode is especially interesting if energy price is integrated in the control system of the overall heating system.

### 2.3. Control strategy

As shown in Figure 1, the system allows for a variety of control strategies through a large number of control valves and a regulated water pumps. The selected strategy includes two levels:

- A temperature-controlled strategy for charging the LHS using the heat pump and discharging the LHS at the return inlet of the hot side of the heat pump.
- A price-controlled strategy where the energy price is taken into account to decide (1) when to harvest heat from the district heating network or from excess production of the photovoltaic panels installed on the building facade and (2) when to use the LHS unit as direct heat sources for the building heating circuit.

At first, the LHS unit will be tested within the time- and temperature-controlled routine of the building, allowing charging of the LHS at night and discharging during daytime, when the return temperature to the heat pump is lower than 34 °C. The energy level of the LHS unit is followed up using thermocouples located at various locations in the unit. Full charge is indicated by an average PCM temperature 4 K above its melting temperature range. Full discharge is indicated by an average PCM temperature 4 K below its solidification temperature range. In addition, an energy meter enables to track the heat output and accumulated transferred energy to follow up the thermal performance of the LHS unit. The control system of the LHS system is fully integrated in the building control system, which includes a "researcher mode" to allow customizing and testing various control strategies.

### 3. DESIGN

#### 3.1. PCM selection and performance testing

To be suitable to the application, the PCM should primarily have a melting temperature within 35-37 °C and limited supercooling. This limits the PCM selection to only a limited range of commercially available paraffin based PCMs. After investigation, the PCM CrodaTherm 37 (CT37) was selected due to its low degree of supercooling (cf. Table 1), its low-carbon footprint as well as its affordability. CT37 is a water-insoluble organic PCM, derived from plant-based feedstocks (Crodatherm, 2019). The PCM appears as a crystalline wax in solid state and oily liquid above melting temperature. In addition, CT37 has low flammability, which is an essential criterion in buildings.

A sample of CT37 received by CrodaTherm was analysed by Thermogravimetric Analysis – Differential Scanning Calorimetry (TGA/DSC) at the SINTEF Energy Research Laboratory to evaluate the thermodynamic performance of the PCM. A measurement of 10 melting/solidification cycles was performed using a TGA/DSC SDT600 from TA Instruments, with controlled heating and cooling rates of 1 K/min ranging from 30 °C to 50 °C, in a nitrogen atmosphere. The results for the second cycle are shown in Figure 2. As indicated by the manufacturer, the first melting displays a significantly larger latent heat of fusion than the following melting/solidification cycles. Taking into account only the 9 following cycles, CT37 remains absolutely stable, yielding very similar heat flow patterns. The average latent heat of fusion is 198.6 kJ/kg (+/- 0.9 %) and the average latent heat of crystallisation is 196.4 kJ/kg (+/- 0.7 %). The average peak melting temperature is 36.5 °C (+/- 0.3 %) and the average solidification temperature peak is 34.5 °C (+/- 0.1 %). The weight loss is measured to 0.04 % along the first two cycles and then remains stable for the following 8 cycles. It should be underlined that thermodynamic property measurements might be variable from one device to another and is also known to depend on the sample mass and measurement procedure.

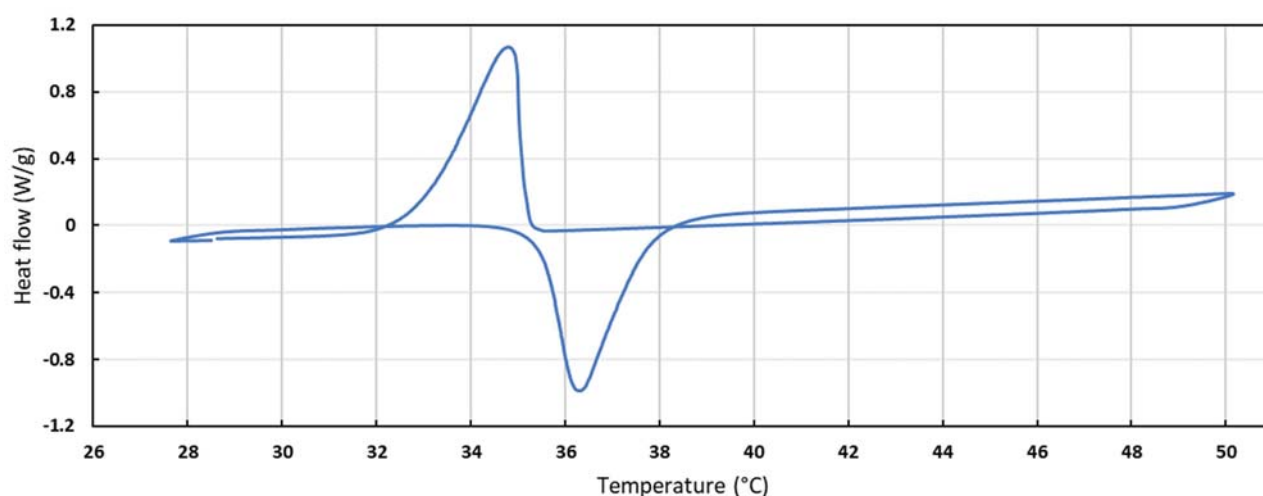

Figure 2: DSC measurements of a sample of CT37. Heat flow absorbed and released for the second melting/solidification cycle.

#### 3.2. General design

The general design parameter of the LHS unit are given in Table 1. The LHS unit dimensions are the first constraints to consider for the unit design due to the architecture of the building, limiting the access into the technical room through a 1.8-m wide corridor and 2-m high doors. The dimensions of the LHS unit are derived from these constraints and the requirements of about 200 kWh total heat storage capacity, as mentioned in Section 2.1. Since the PCM is not pressurized, the geometry of the LHS unit is relatively free. The LHS unit was initially designed based on a fin-and-tube heat exchanger, filled with PCM and with water from the heating circuit circulating in the tubes. Further literature search (Selvnes et al., 2019) and later discussions with heat exchanger manufacturers showed that a custom pillow-plate heat exchanger design (cf. Figure 3) was better suited to ensure higher heat output delivered by the LHS unit as well as higher durability while being more compact for an equivalent thermal storage capacity.

**Table 1: General characteristics of the LHS unit using a custom pillow-plate heat exchanger design.**

Dimensions of LHS unit (height * width * length) [m]	1.5 * 1.4 * 2.25
Measured PCM melting temperature range [°C]	35 – 39 (heat flow peak at 36.5)
Measured PCM solidification temperature range [°C]	32.5 – 35.5 (heat flow peak at 34.5)
Measured PCM latent heat of fusion [kJ/kg]	198.6
Measured PCM latent heat of crystallisation [kJ/kg]	196.4
PCM density [kg/m <sup>3</sup> ]	957 (at 32 °C), 819 (at 75 °C)
PCM thermal conductivity [W/(m.K)]	0.24
PCM specific heat capacity [kJ/(kg.K)]	2.3 (solid), 1.4 (liquid)
PCM degradation temperature [°C]	> 50
Total theoretical thermal storage capacity [from 30 to 40 °C] [kWh]	194
Ratio of latent heat to total heat storage capacity	87 %

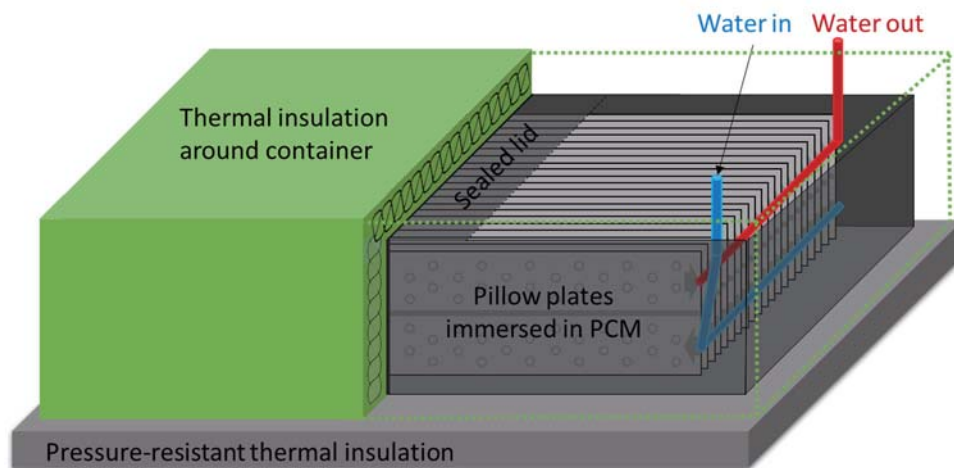

**Figure 3: Simplified geometry of the LHS unit. The PCM (not shown here) fills up the space between the pillow plates.**

The original design parameters of the fin-and-tube heat exchanger were determined based on dynamic system simulations reported in (Sevault et al., 2019). The model was based on a solid-liquid fin-and-tube heat exchanger using PCM for TES, custom-made by TLK-Thermo GmbH (2019) in 2017 and utilised in previous works (Jokieli et al., 2019). These results especially contributed to determine the fin pitch (distance between the plates) necessary to ensure a heat transfer rate during discharge above 12 kW over 6 hours to meet the maximum heating demand in combination with the heat pump. Scaling the previous results to the new heat exchanger in terms of equivalent heat transfer area led to a pitch of 40 mm between the pillow plates to guarantee heat flows above 12 kW for at least 6 hours during discharge in the given operational conditions.

The heat exchanger includes 24 laser-welded stainless-steel pillow-plates, mounted vertically in parallel with a 40-mm pitch. Water circulates in each of them following a 2-pass pattern. Headers are gathered at one end of the unit to enable a homogeneous distribution of the water across the pillow-plates. The heat exchanger is filled with ca. 3 tons of PCM CT37 to occupy the volume between the pillow plates. A thick mineral wool thermal insulation around the LHS-unit allows for a theoretical heat loss under 2 % per 24 h. Installation of the LHS unit is on-going and full commissioning is planned in December 2020.

#### 4. CONCLUSION

The aim of the study is to design and integrate a LHS unit in the central heating system of the ZEB Laboratory building in Trondheim (Norway). The LHS unit is designed based on pillow-plate heat exchanger filled with PCM whose phase change temperature is 35-37 °C. The designed LHS unit can store up to 194 kWh heat and simultaneously achieve sufficiently high heat transfer rates during discharge to successfully back up the heat pump during the coldest winter days or be used as a heat source in the central heating system. Installation is on-going and first tests are planned in Autumn 2020.

## ACKNOWLEDGEMENTS

The current study was carried out through the competence-building project PCM-Eff supported by SINTEF Energy Research using basic funding from the Research Council of Norway. The project aims at investigating novel phase change material solutions for efficient thermal energy storage at low and medium-high temperature ([www.sintef.no/en/projects/pcm-eff/](http://www.sintef.no/en/projects/pcm-eff/)). The LHS unit is co-financed through the ZEB Laboratory by SINTEF, NTNU, Research Council of Norway and ENOVA.

## REFERENCES

- Time, B., et al. ZEB Laboratories – Research Possibilities. IOP Conference Series: Earth and Environmental Science, Volume 352, 1st Nordic conference on Zero Emission and Plus Energy Buildings 6–7 November 2019, Trondheim, Norway.
- Shukla, A., D. Buddhi, and R.L. Sawhney, Thermal cycling test of few selected inorganic and organic phase change materials. *Renewable Energy*, 2008. 33(12): p. 2606-2614.
- Sevault, A., et al., Phase change materials for thermal energy storage in low- and high-temperature applications: a state-of-the-art, SINTEF Energy Research Report TR A7638 - ISBN 978-82-594-3684-9. 2017.
- Hirmiz, R., et al., Performance of heat pump integrated phase change material thermal storage for electric load shifting in building demand side management. *Energy and Buildings*, 2019. 190: p. 103-118.
- Jokiel, M., et al. Phase change material thermal energy storage for a large scale ammonia chiller/heat pump system. in 7th Conference on Ammonia and CO<sub>2</sub> Refrigeration Technology. Proceedings: Ohrid, Macedonia, Mai 11-13, 2017. 2017. International Institute of Refrigeration.
- Modelica and the Modelica Association - Modelica. 2019, cited 2019; Available from: <https://modelica.org/>.
- Bonamente, E., A. Aquino, and F. Cotana, A PCM Thermal Storage for Ground-source Heat Pumps: Simulating the System Performance via CFD Approach. *Energy Procedia*, 2016. 101: p. 1079-1086.
- Moreno, P., et al., PCM thermal energy storage tanks in heat pump system for space cooling. *Energy and Buildings*, 2014. 82: p. 399-405.
- Crodatherm 37 - Datasheet, C.I. Plc, Editor. Consulted in May 2019.
- Selvnes, H., et al. A CFD analysis for the performance assessment of a novel design of plates-in-tank latent storage unit for freezing applications. I: 8th Conference on Ammonia and CO<sub>2</sub> Refrigeration Technologies, Proceedings. International Institute of Refrigeration 2019 ISBN 978-2-36215-034-0. s. 303-310
- Sevault, A., et al., Latent heat storage for centralized heating system in a ZEB living laboratory: integration and design, IOP Conference Series: Earth and Environmental Science, Volume 352, 1st Nordic conference on Zero Emission and Plus Energy Buildings 6–7 November 2019, Trondheim, Norway.
- TLK-Thermo GmbH, TIL Suite Thermal Systems. 2019. Available from: <https://www.tlk-thermo.com/index.php/en/software-products/til-suite>.
- Jokiel, M., et al., Dynamic modelling of a refrigerated cabinet with integrated phase change material thermal storage. *International Journal of Refrigeration*, Proceedings of the 25th International Congress of Refrigeration, August 24-30, Montreal (Canada), 2019.