

Efficient hydrogen production with CO₂ capture using gas switching reforming (GSR): Techno-economic assessment

Shareq Mohd Nazir^a, Jan Hendrik Cloete^b, Schalk Cloete^b, Shahriar Amini^{a,b}

^a Norwegian University of Science and Technology, Trondheim, Norway, shareq.m.nazir@ntnu.no (CA)

^b Sintef Industry, Trondheim, Norway, shahriar.amini@sintef.no

Abstract:

Hydrogen is identified as one of the clean energy carriers in the future energy scenario. This work presents a process to produce low cost hydrogen with CO₂ capture using gas switching reforming (GSR). The process steps include GSR, water-gas shift, pure hydrogen recovery in pressure-swing adsorption process and CO₂ and hydrogen compression trains. The overall process, denoted as GSR-H2, produces 99.999% pure hydrogen with >96% CO₂ capture. In this study, GSR-H2 is compared economically with the conventional steam-methane reforming (SMR) plant that produces hydrogen without CO₂ capture. GSR-H2 produces 10% more hydrogen when compared to the SMR plant, but consumes significant imported electricity. The cost of hydrogen produced from the GSR-H2 and SMR plant is similar (1.67 €/kg-H₂) with a CO₂ tax of only 20 €/ton, even with GSR-H2 being a near zero emission plant. In a future energy scenario where the CO₂ emission tax is high and the electricity price is low, GSR-H2 will significantly outperform the conventional SMR plant.

Keywords:

Hydrogen production, CO₂ capture, Natural gas reforming, Techno-economic assessment, Novel gas switching reforming process.

1. Introduction

The recent release of the IPCC report [1] about limiting the global temperature rise to 1.5°C has emphasized on reducing the greenhouse gas emissions and stressed upon the possibility of hydrogen as carbon-free energy carrier during the phase of energy transition in industry, transport and power sector. Nearly 48% of the hydrogen produced comes from natural gas – steam reforming [2]. Most of this hydrogen is produced in a steam-methane reforming (SMR) plant that has an equivalent hydrogen production efficiency of 81% [3] and releases 8-9 ton CO₂ per ton of H₂ produced [4]. However, the efficiency drops by nearly 14%-points [3] when the SMR plant is integrated with conventional amine absorption based CO₂ capture method. Therefore, technologies for H₂ production with CO₂ capture and higher efficiency have gained momentum in recent years.

One way to limit the energy penalty when integrating CO₂ capture with hydrogen production is through chemical looping technology. The concept of chemical looping was introduced by Richter and Knoche [5] and is applied in studying a power generation process [6, 7] using chemical looping combustion (CLC). Another variant of the chemical looping technology is chemical looping

reforming (CLR) [8, 9], where the carbon containing fuel is partially oxidised to form syngas, which can further be processed to prepare pure hydrogen. A schematic of the CLR process is shown in *Figure 1(a)*. The CLR process consists of two interconnected fluidized bed reactors, oxidation and fuel reactor, with the metallic oxygen carrier circulating between the two. The oxygen carrier is oxidised with air in the oxidation reactor, which also gives a depleted air stream (N_2 stream) as a by-product. The oxygen carrier is sent to the fuel reactor for natural gas reforming in the presence of steam. Syngas is formed in the fuel reactor and the reduced oxygen carrier is circulated back to the oxidation reactor. The use of CLR in pre-combustion capture process is illustrated in [10, 11], whereas [12, 13] shows that CLR is suited more for base-load power generation and less for hydrogen production, since the purity of hydrogen (<96 mol%) produced is not very high as the process does not allow for an easy integration of a pressure swing adsorption (PSA) unit. CLR also presents challenges with scaling up and operating the reactors at higher pressures.

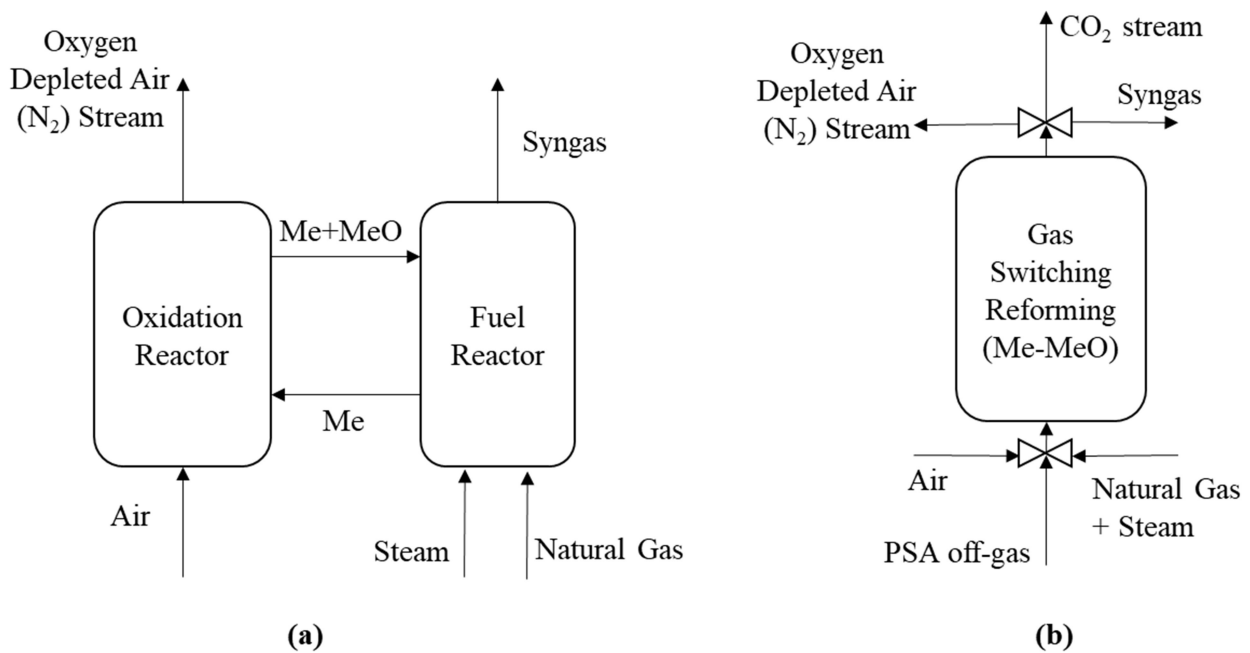

Figure 1. Schematic of (a) Chemical Looping Reforming (b) Gas Switching Reforming

To offset the challenges in CLR, a novel gas switching reforming (GSR) concept is proposed [14] and experimentally demonstrated. The schematic of GSR process is shown in *Figure 1(b)*. Instead of circulating the oxygen carrier as in CLR, the gases are switched between reaction steps in the GSR reactor. The GSR is operated as a bubbling fluidized bed reactor in three different steps, i) oxidation ii) reduction iii) reforming. The oxidation step is similar to the CLR oxidation step. The oxygen carrier is reduced with the PSA off gas in the reduction step. The reduction step produces a stream of CO_2 and H_2O , from which, H_2O is condensed to obtain a pure CO_2 stream for transport and storage. The reduced oxygen carrier acts as a catalyst for steam-methane reforming to produce syngas in the reforming step of the GSR.

Using GSR for power production with CO_2 capture [15] yields a higher net electrical efficiency for the gas-fired power plant when compared to power plants with post-combustion absorption methods. The techno-economics of a GSR based power plant [16] is available in literature. However, there is still a gap in literature when it comes to pure hydrogen production process using GSR. This paper presents a first of its kind techno-economic analysis of a hydrogen production process with CO_2 capture using gas switching reforming, a process denoted as GSR-H2 hereafter. The techno-economic behaviour of the GSR-H2 process is compared against the reference SMR plant without CO_2 capture. The performance indicators in this study are the equivalent hydrogen production efficiency, CO_2 capture rate, specific primary energy consumption for CO_2 avoided (SPECCA) and levelised cost of hydrogen. Section 2 of the paper contains the description of the

processes for reference SMR plant and GSR-H2. The modelling assumptions and the methodology for economic analysis are presented in section 3. Section 4 contains the results and discussions followed by conclusions in section 5.

2. Process Description

2.1. Reference steam methane reforming (SMR) process

The schematic of the reference SMR plant is shown in *Figure 2*. The SMR plant studied in this paper is similar to the one presented by Martínez, Romano [17], but it has been reproduced in this study to maintain consistency between the modelling assumptions. Natural gas (NG) is pre-heated and de-sulphurized before mixing it with steam. The NG and steam mixture is pre-heated and sent for pre-reforming to convert the higher hydrocarbons into CH_4 . The outlet from the pre-reformer has a steam to carbon ratio (S/C) of 2.70, which is pre-heated and sent to the reformer. The reformer in this case is a fired tubular reformer (FTR), which contains Ni-based catalysts to convert nearly 80% of the CH_4 . FTR operates at 32.7 bar. The steam methane reforming reaction is an endothermic reaction, and hence the heat for the reaction is provided by combusting PSA off gas and a fraction of de-sulphurized NG with air. The syngas from the FTR is cooled and sent to the water-gas shift (WGS) reactor where the CO and H_2O in the syngas is converted to CO_2 and H_2 . The WGS outlet is cooled to a temperature where the H_2O in the syngas is completely condensed, before the syngas is sent to PSA to recover 99.999% pure H_2 . The PSA off gas is sent to the FTR burner whereas pure H_2 is compressed to 150 bar and 30 °C. The pre-heating of the streams in the process is done through heat recovery from the combustion exhaust gas from the FTR (burner). High pressure superheated steam (92 bar and 485 °C) is prepared by recovering heat from syngas coming out from the FTR, WGS outlet and combustion exhaust gas from FTR. Superheated steam is expanded in the steam turbine, where fraction of steam is extracted for reforming and the remainder is exported at 6 bar and 165 °C.

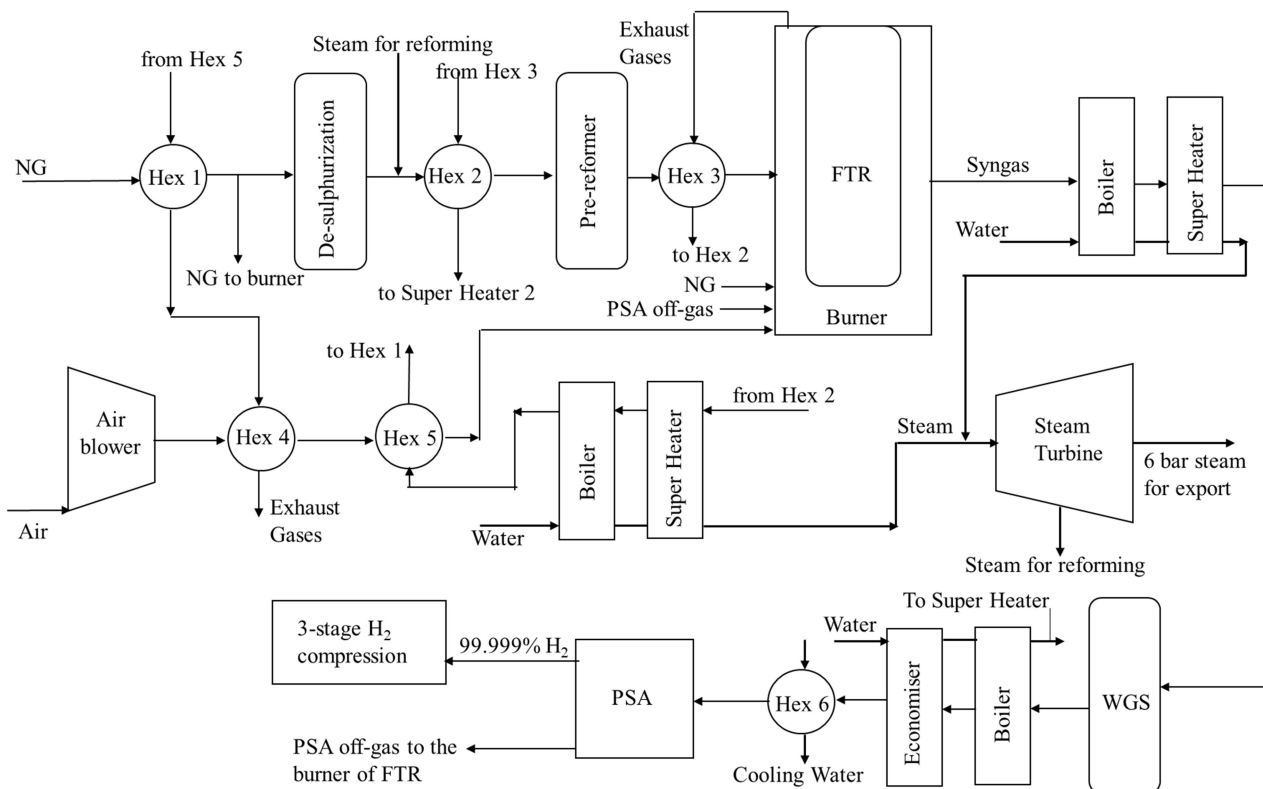

Figure 2. Schematic of the reference SMR plant

2.2. Hydrogen plant with gas switching reforming and CO₂ capture (GSR-H2)

Figure 3 shows the schematic of the GSR-H2 plant. The steps until pre-reformer are the same as in SMR plant, except that the pre-heating of NG and NG-steam mixture is done with hot syngas from the GSR. The S/C ratio at the inlet of the GSR is 2.66, and GSR is operated at 32.7 bar (similar to FTR). Syngas from the GSR is cooled and sent to WGS reactor to convert the most of the H₂O and CO into CO₂ and H₂. Syngas containing mainly H₂ and CO₂ is cooled to 25 °C and sent to PSA for pure H₂ (99.999 mol%) recovery. H₂ is then compressed to 150 bar and 30 °C in three stages. The PSA off-gas is compressed and sent to the reduction step of the GSR. Reduction step outlet from the GSR mainly contains CO₂ and H₂O. H₂O is condensed and the CO₂ stream is compressed for transport and storage. Steam for reforming is produced from heat recovery from the WGS outlet, GSR reduction step outlet and the N₂ stream from the GSR oxidation step. N₂ stream is further expanded in the turbine to extract power before being vented.

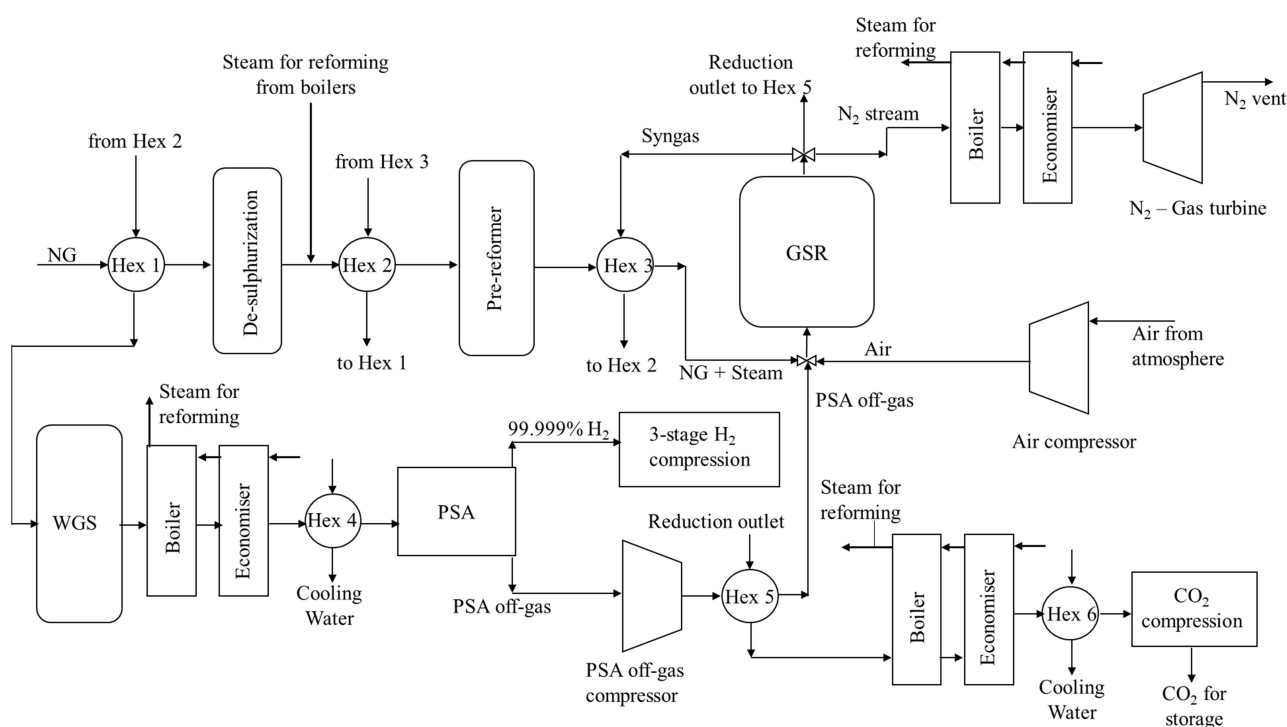

Figure 3. Schematic of the GSR-H2 process

3. Methodology

The section is divided in two parts. Firstly, assumptions in modelling and simulation of the processes are presented. Secondly, the methodology, followed to estimate the techno-economic performance indicators, is presented.

3.1. Modelling assumptions

The SMR and GSR-H2 process are simulated using Aspen Hysys V8.6, except the GSR reactor and PSA unit. Peng-Robinson equation of state is used to estimate the thermodynamic properties within the process. A 0D model [15] developed using Matlab is used for GSR reactor. The PSA unit is modelled as a black box, with H₂ recoveries obtained from a linearly regressed equation obtained for data points available in literature. The conditions for air and NG, pressure drops for heat exchangers and the final conditions for CO₂ compressed and stored is taken from EBTF [18], whereas the remaining assumptions for compressors, reactors and turbines are similar to assumptions in Spallina, Pandolfo [3] and Martínez, Romano [17]. The NG input flow to the process is assumed 10000 kg/hr for both the plants.

3.2. Methodology for techno-economic assessment

The technical performance indicators for the process are evaluated as follows. Detailed description of each term is presented by Martínez, Romano [17]. Equation (1) gives the equivalent NG use in the process. Equation (2) gives the energy content of the exported steam. Equation (3) and (4) gives the hydrogen production efficiency and its equivalent. Equation (5) and (6) gives the measure of CO₂ capture and its equivalent respectively using the values of E_{NG}=56.8 g_{CO2}/MJ_{LHV}, E_{th}=63.3 g_{CO2}/MJ and E_{el}=97.7 g_{CO2}/MJ. Equation (9) gives the specific primary energy consumption for CO₂ avoided (SPECCA) using the carbon intensity obtained from (7) and (8).

$$m_{eq,NG} = \dot{m}_{NG} \times LHV_{NG} - \frac{Q_{th}}{0.9} - \frac{W_{el}}{0.583} \quad (1)$$

$$Q_{th} = \dot{m}_{steam\ export} \times (h_{steam@6bar} - h_{liqsat@6bar}) \quad (2)$$

$$\eta_{H_2} = \frac{100\% \times \dot{m}_{H_2} \times LHV_{H_2}}{\dot{m}_{NG} \times LHV_{NG}} \quad (3)$$

$$\eta_{eq,H_2} = \frac{100\% \times \dot{m}_{H_2} \times LHV_{H_2}}{\dot{m}_{eq,NG} \times LHV_{NG}} \quad (4)$$

$$CC = \frac{100\% \times \text{mass of } CO_2 \text{ captured}}{\dot{m}_{NG} \times LHV_{NG}} \quad (5)$$

$$CC_{eq} = \frac{100\% \times \text{mass of } CO_2 \text{ captured}}{\dot{m}_{NG} \times LHV_{NG} \times E_{NG} - Q_{th} \times E_{th} - W_{el} \times E_{el}} \quad (6)$$

$$E_{CO_2} = \frac{\text{mass of } CO_2 \text{ emitted}}{\dot{m}_{H_2} \times LHV_{H_2}} \quad (7)$$

$$E_{eq,CO_2} = \frac{\text{mass of } CO_2 \text{ emitted} - Q_{th} \times E_{th} - W_{el} \times E_{el}}{\dot{m}_{H_2} \times LHV_{H_2}} \quad (8)$$

$$SPECCA = 1000 \times \frac{\frac{1}{\eta_{eq,H_2}} - \frac{1}{\eta_{eq,H_2,ref}}}{E_{eq,CO_2,ref} - E_{eq,CO_2}} \quad (9)$$

The economic analysis is carried out based on the methodology presented by GCCSI [19] to estimate the levelised cost of hydrogen (LCOH) using (10).

$$LCOH = \frac{(TCR)(FCF) + FOM}{(kg - H_2)(CF * 8766)} + VOM + (FC)(HR) \quad (10)$$

Where TCR is the total capital requirement, FCF is the fixed charge factor for the lifetime of the plant, CF is the capacity factor of the plant (90% in this study), FOM is the fixed operating cost, VOM is the variable operating cost and (FC)(HR) is the fuel cost component in the LCOH. TCR is calculated as shown in

Table 1.

The capital cost for the process equipment is considered similar to [3]. However, for the costs that are not available, economics tool in Aspen Hysys V8.6 and Thermoflow suite V26 is used to obtain the costs of the equipment. The FOM and VOM is evaluated similar to the procedure followed by Spallina, Pandolfo [3]. The cost of steam exported is assumed based on the electric power it can produce when expanded. The rate of return is assumed 10% with plant life of 30 years.

Table 1: Method to calculate total capital requirement (TCR)

Component	Definition
Bare Erected Cost (BEC)	Sum of installed cost of equipment
Engineering Procurement Construction Costs (EPCC)	8% of BEC
Process Contingency	30% of BEC for GSR reactor. 0% for other process components.
Project Contingency	10% of (BEC + EPCC + Process Contingency)
Total Contingencies	Process Contingency + Project Contingency
Total Plant Costs (TPC)	BEC + EPCC + Total Contingencies
Owners Cost	20.2% of TPC [20]
Total Overnight Costs (TOC)	TPC + Owners Cost
Total Capital Requirement (TCR)	1.14*TOC [20]

4. Results and Discussion

The main results for the techno-economic analysis of the reference SMR process and the GSR-H2 process is shown in Table 2. For the results shown in Table 2, the cost of NG is assumed as 6 €/GJ-LHV, CO₂ transport and storage costs as 10 €/t-CO₂, CO₂ emission tax as 20 €/t-CO₂ and the electricity price as 60 €/MWh.

Table 2: Main results for techno-economic analysis for SMR plant and the GSR-H2 process

	Unit	SMR plant	GSR-H2
Technical analysis			
$m_{eq,NG}$ (Eq 1)	kg/hr	9828	11402
Net electricity consumption	MW	0.43	10.56
Hydrogen produced	kg/hr	3021	3335
Hydrogen production efficiency	%	77.92	86.03
Equivalent hydrogen production efficiency	%	79.28	75.45
CO ₂ capture	%	-	96.21
Equivalent CO ₂ capture	%	-	84.35
SPECCA	MJ/kg-CO ₂	-	1.06
Economic analysis			
Fuel cost element (FC*HR)	€/kg-H ₂	0.92	0.84
Variable O&M cost element	€/kg-H ₂	0.21	0.30
Fixed O&M cost element	€/kg-H ₂	0.19	0.19

Total capital requirement element	€/kg-H ₂	0.35	0.34
Levelised cost of hydrogen (LCOH)	€/kg-H ₂	1.67	1.67

It is clear from the reference SMR process in *Figure 2* and GSR-H2 process in *Figure 3* that the GSR-H2 process has additional process steps with respect to PSA off-gas compression and CO₂ compression for transport and storage. In addition, air is compressed to GSR reactor pressure in the GSR-H2 process for the oxidation step. Hence, the net electric power consumption in the GSR-H2 process is much higher than the SMR plant as shown in *Table 2*. The hydrogen production efficiency in the GSR-H2 process is higher than the SMR plant but the equivalent hydrogen production is lower. The equivalent hydrogen production efficiency accounts for the additional NG used to produce electricity in a separate power plant. GSR-H2 achieves a CO₂ capture rate of >96% and the equivalent CO₂ capture rate >84%. The equivalent CO₂ capture accounts for the CO₂ emissions per unit of electric power imported (or consumed).

For the assumptions in this study, the LCOH for GSR-H2 with >96% CO₂ capture is same as the LCOH of reference SMR plant without CO₂ capture. GSR-H2 has lower fuel costs compared to SMR because the hydrogen production efficiency is high. The variable operating and maintenance cost in GSR-H2 is higher than in SMR because of the net electricity imported, which imposes a significantly larger cost than the CO₂ emissions tax paid by the SMR plant. The fixed operating and maintenance costs and the capital requirements elements are the nearly same for the GSR-H2 and SMR plants. Therefore, the LCOH of the process is highly sensitive to the fuel cost (NG price), followed by capital requirement, variable operating and maintenance cost, and fixed operating and maintenance costs in the respective order. *Figure 4* shows the sensitivity of the cost of hydrogen towards the cost components that influence the fuel costs and variable operating and maintenance costs.

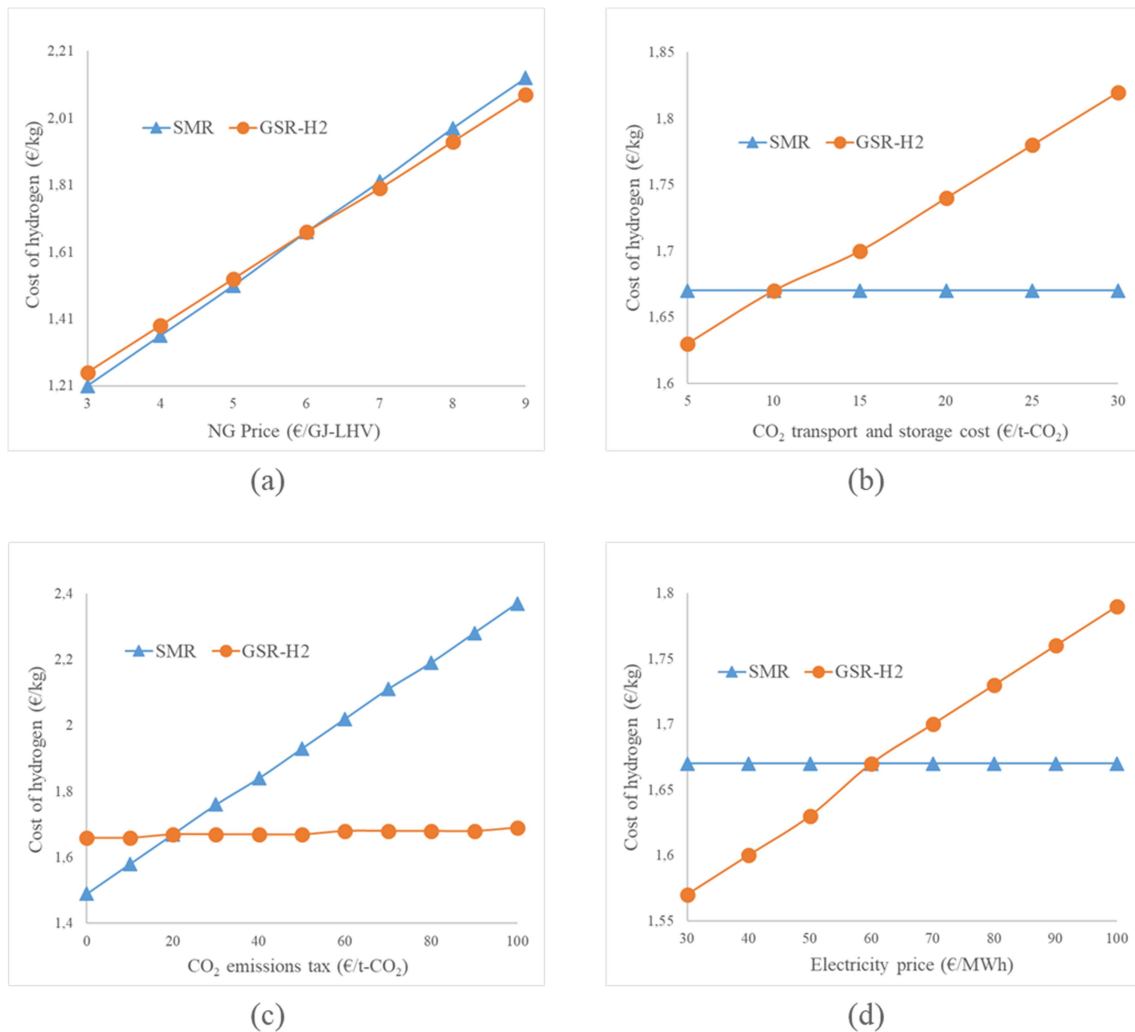

Figure 4: Sensitivity of cost of hydrogen towards (a) NG price (b) CO₂ transport and storage cost (c) CO₂ emissions tax (d) Electricity price

As seen in Figure 4a, both the SMR and GSR-H2 process are highly sensitive to the NG price, whereas the GSR-H2 produces hydrogen at lower cost when the NG price is more than 6 €/GJ-LHV. The amount of CO₂ emitted from a hydrogen plant producing 3-4 TPH of hydrogen is much lower compared to large scale CO₂ emitters like power plants. Hence, the CO₂ transport and storage costs will vary [21] depending on the size of the plant. For every 10 €/t-CO₂ increase in the CO₂ transport and storage cost, the cost of hydrogen for the GSR-H2 process increases by 4-5% (Figure 4b), whereas the cost of hydrogen from the SMR plant does not change since there is no CO₂ capture. In future, it is expected that the CO₂ emission tax will be higher so that the industries take measures to reduce emissions. As seen in Figure 4c, the increase in CO₂ emission tax will have no effect on the GSR-H2 process since >96% of the CO₂ is captured. For the SMR plant, if the CO₂ emission tax increases by 10 €/t-CO₂, the cost of hydrogen increases by 4-6%. For all the other cost components remaining same, a mere 20 €/t-CO₂ emission tax value makes the hydrogen from the GSR-H2 cheaper than the SMR plant without CO₂ capture. For every 10 €/MWh increase in the electricity price, the cost of hydrogen from the GSR-H2 process increase by 2% (Figure 4d), whereas it has negligible effect on the cost of hydrogen from SMR plant. At lower electricity prices, the cost of hydrogen from the GSR-H2 process with CO₂ capture is lower than that of the SMR plant without CO₂ capture.

5. Conclusions

A novel gas switching reforming reactor is integrated with CO₂ capture for pure hydrogen production in a process denoted as GSR-H2. Techno-economic analysis of the GSR-H2 process is

carried out and compared with the reference steam-methane reforming plant without CO₂ capture. The GSR-H2 plant has a 10% higher hydrogen production efficiency with >96% CO₂ capture when compared to a reference steam methane reforming (SMR) plant without any CO₂ capture. However, the equivalent hydrogen production efficiency of the GSR-H2 is ~4%-points lower than the SMR plant, because of higher electricity consumption in additional components related to PSA off-gas and CO₂ stream compression. The SPECCA for the GSR-H2 process is 1.06 MJ/kg-CO₂.

The economic analysis reveals that the SMR and GSR-H2 processes are highly sensitive to the fuel cost (NG price). A sensitivity study for cost of hydrogen with components in variable operating and maintenance costs reveals the potential of GSR-H2 process in the future energy scenario. In a scenario with increasing CO₂ emissions tax rate and lower electricity prices, GSR-H2 will outperform the conventional SMR technology when the CO₂ tax exceeds €20/ton and can produce low cost hydrogen with near zero emissions. Future studies will further optimize the GSR-H2 process through a higher degree of heat integration and improved reactor design.

Acknowledgments

The current work is part of “GaSTech” project under the Horizon 2020 programme, ACT Grant Agreement No 691712. The authors appreciate the funding authorities, the Research Council of Norway and the European Commission. The authors also appreciate the project partners in GaSTech.

References

- [1] IPCC, *Global Warming of 1.5°C: Summary for Policymakers*. 2018.
- [2] Voldsund, M., K. Jordal, and R. Anantharaman, *Hydrogen production with CO₂ capture*. International Journal of Hydrogen Energy, 2016. **41**(9): p. 4969-4992.
- [3] Spallina, V., et al., *Techno-economic assessment of membrane assisted fluidized bed reactors for pure H₂ production with CO₂ capture*. Energy Conversion and Management, 2016. **120**: p. 257-273.
- [4] CSLF, *Task Force on Hydrogen Production and CCS*. 2018, Carbon Sequestration Leadership Forum.
- [5] Richter, H.J. and K.F. Knoche, *REVERSIBILITY OF COMBUSTION PROCESSES*. ACS Symposium Series, 1983: p. 71-85.
- [6] Ishida, M. and H. Jin, *A new advanced power-generation system using chemical-looping combustion*. Energy, 1994. **19**(4): p. 415-422.
- [7] Ishida, M., D. Zheng, and T. Akehata, *Evaluation of a chemical-looping-combustion power-generation system by graphic exergy analysis*. Energy, 1987. **12**(2): p. 147-154.
- [8] Pröll, T., et al., *Syngas and a separate nitrogen/argon stream via chemical looping reforming - A 140 kW pilot plant study*. Fuel, 2010. **89**(6): p. 1249-1256.
- [9] Rydén, M., A. Lyngfelt, and T. Mattisson, *Synthesis gas generation by chemical-looping reforming in a continuously operating laboratory reactor*. Fuel, 2006. **85**(12-13): p. 1631-1641.
- [10] Nazir, S., O. Bolland, and S. Amini, *Analysis of Combined Cycle Power Plants with Chemical Looping Reforming of Natural Gas and Pre-Combustion CO₂ Capture*. Energies, 2018. **11**(1): p. 147.
- [11] Nazir, S.M., O. Bolland, and S. Amini, *Full Plant Scale Analysis of Natural Gas Fired Power Plants with Pre-Combustion CO₂ Capture and Chemical Looping Reforming (CLR)*. Energy Procedia, 2017. **114**: p. 2146-2155.
- [12] Nazir, S.M., et al., *Techno-economic assessment of chemical looping reforming of natural gas for hydrogen production and power generation with integrated CO₂ capture*. International Journal of Greenhouse Gas Control, 2018. **78**: p. 7-20.

- [13] Francisco Morgado, J., et al., *Modelling study of two chemical looping reforming reactor configurations: looping vs. switching*. Powder Technology, 2017. **316**: p. 599-613.
- [14] Wassie, S.A., et al., *Hydrogen production with integrated CO₂ capture in a novel gas switching reforming reactor: Proof-of-concept*. International Journal of Hydrogen Energy, 2017. **42**(21): p. 14367-14379.
- [15] Nazir, S.M., et al., *Gas switching reforming (GSR) for power generation with CO₂ capture: Process efficiency improvement studies*. Energy, 2019. **167**: p. 757-765.
- [16] Nazir, S.M., et al., *Techno-economic assessment of the novel gas switching reforming (GSR) concept for gas-fired power production with integrated CO₂ capture*. International Journal of Hydrogen Energy, 2018. **43**(18): p. 8754-8769.
- [17] Martínez, I., et al., *Hydrogen production through sorption enhanced steam reforming of natural gas: Thermodynamic plant assessment*. International Journal of Hydrogen Energy, 2013. **38**(35): p. 15180-15199.
- [18] EBTF, *European best practice guidelines for assessment of CO₂ capture technologies. CESAR -project 7th FrameWork Programme. Collaborative Project– GA No. 213569*. 2011.
- [19] GCCSI, *Global CCS Institute - TOWARD A COMMON METHOD OF COST ESTIMATION FOR CO₂ CAPTURE AND STORAGE AT FOSSIL FUEL POWER PLANTS*. 2013.
- [20] NETL, *Cost Estimation Methodology for NETL Assessments of Power Plant Performance*. 2011.
- [21] Roussanaly, S., G. Bureau-Cauchois, and J. Husebye, *Costs benchmark of CO₂ transport technologies for a group of various size industries*. International Journal of Greenhouse Gas Control, 2013. **12**: p. 341-350.