

# BUILDING SERVICES SOLUTIONS SUITABLE FOR LOW EMISSION URBAN AREAS

ZEN REPORT No. 26 – 2020





Research Centre on  
ZERO EMISSION  
NEIGHBOURHOODS  
IN SMART CITIES

## ZEN Report No. 26

Øystein Rønneseth<sup>1</sup>, Matthias Haase<sup>1</sup>, Laurent Georges<sup>2</sup>, Kari Thunshelle<sup>1</sup>, Sverre Bjørn Holøs<sup>1</sup>, Øystein Fjellheim<sup>1</sup>, Mads Mysen<sup>1</sup>, Judith Thomsen<sup>1</sup>

<sup>1</sup>) SINTEF Community, <sup>2</sup>) Norwegian University of Science and Technology (NTNU)

### Building Services Solutions Suitable for a Low Emission Urban Areas

Keywords: Demand controlled ventilation, ventilation-based heating and cooling, simplified hydronic heating, personal heating and cooling, smart energy control, responsive lighting equipment, low-temperature thermal heating.

ISBN 978-82-536-1677-3

Norwegian University of Science and Technology (NTNU) | [www.ntnu.no](http://www.ntnu.no)

SINTEF Community | [www.sintef.no](http://www.sintef.no)

<https://fmezen.no>

## Preface

### Acknowledgements

This report has been written within the Research Centre on Zero Emission Neighbourhoods in Smart Cities (FME ZEN). The author gratefully acknowledge the support from the Research Council of Norway, the Norwegian University of Science and Technology (NTNU), SINTEF, the municipalities of Oslo, Bergen, Trondheim, Bodø, Bærum, Elverum and Steinkjer, Trøndelag county, Norwegian Directorate for Public Construction and Property Management, Norwegian Water Resources and Energy Directorate, Norwegian Building Authority, ByBo, Elverum Tomteselskap, TOBB, Snøhetta, Asplan Viak, Multiconsult, Sweco, Civitas, FutureBuilt, Hunton, Moelven, Norcem, Skanska, GK, Nord-Trøndelag Elektrisitetsverk - Energi, Smart Grid Services Cluster, Statkraft Varme, Energy Norway, Norsk Fjernvarme and AFRY.

### The Research Centre on Zero Emission Neighbourhoods (ZEN) in Smart Cities

The ZEN Research Centre develops solutions for future buildings and neighbourhoods with no greenhouse gas emissions and thereby contributes to a low carbon society.

Researchers, municipalities, industry and governmental organizations work together in the ZEN Research Centre in order to plan, develop and run neighbourhoods with zero greenhouse gas emissions. The ZEN Centre has nine pilot projects spread over all of Norway that encompass an area of more than 1 million m<sup>2</sup> and more than 30 000 inhabitants in total.

In order to achieve its high ambitions, the Centre will, together with its partners:

- Develop neighbourhood design and planning instruments while integrating science-based knowledge on greenhouse gas emissions;
- Create new business models, roles, and services that address the lack of flexibility towards markets and catalyze the development of innovations for a broader public use; This includes studies of political instruments and market design;
- Create cost effective and resource and energy efficient buildings by developing low carbon technologies and construction systems based on lifecycle design strategies;
- Develop technologies and solutions for the design and operation of energy flexible neighbourhoods;
- Develop a decision-support tool for optimizing local energy systems and their interaction with the larger system;
- Create and manage a series of neighbourhood-scale living labs, which will act as innovation hubs and a testing ground for the solutions developed in the ZEN Research Centre. The pilot projects are Furuset in Oslo, Fornebu in Bærum, Sluppen and Campus NTNU in Trondheim, an NRK-site in Steinkjer, Ydalir in Elverum, Campus Evenstad, NyBy Bodø, and Zero Village Bergen.

The ZEN Research Centre will last eight years (2017-2024), and the budget is approximately NOK 380 million, funded by the Research Council of Norway, the research partners NTNU and SINTEF, and the user partners from the private and public sector. The Norwegian University of Science and Technology (NTNU) is the host and leads the Centre together with SINTEF.



<https://fmezen.no>



@ZENcentre



FME ZEN (page)

## Samandrag

Det er ei oppfatning at energieffektive bygningskroppar med lågt varmetap og lågt soltilskot mogleggjer enklare tekniske installasjonar. Målet med denne rapporten er å samanfatte statusen for nokre lovande tekniske løysingar tilpassa lågutsleppsbygningar i urbane områder. Løysingane er utvalde som relevant for bruk av ZEN-partnarane i ZEN-pilotområda og for vidare forskning innan FME ZEN.

Tabellen nedanfor viser for kva bygningskategoriar dei diskuterte teknologiane er vurdert som ein lovande løysing (+++), mogleg lovande løysing (++) eller løysing ein ventar å ha mindre betydning (+). Bygningskategoriar der den tekniske løysinga ikkje er blitt vurdert er markert (0). Dei ulike teknologiane blir presentert i del II og tabellen blir utdjupa og forklart i kapittel 0.

<i>Bygningskategori / Teknisk løysing</i>	<i>Nye kontor</i>	<i>Renoverte kontor</i>	<i>Skular</i>	<i>Bustadar</i>	<i>Daglegvare-butikkar</i>	<i>Kjøpesentre</i>
<i>Behovsstyrt ventilasjon</i>	Stort innsparingspotensial med etablert teknologi, spesielt opne kontor og møterom		Stort innsparingspotensial med etablert teknologi	Trenger tilpassing til termisk regulering og meir profesjonelt vedlikehald	Utilstrekkeleg informasjon	Utilstrekkeleg informasjon
<i>Ventilasjonsbasert oppvarming</i>	Stort innsparingspotensial med etablert teknologi	Avhengig av varmebehov, vindauge osv.		Ueigna for soverom med lågare temp. krav	Golvvarme, strålevarme eller radiatorar er ikkje praktiske løysingar	Utilstrekkeleg informasjon
<i>Kjøling med høg lufthastighet</i>			Tilpassing til høg brukartettleik er nødvendig	Treng tilpassing til mindre luftstraumar	Lite romkjølingsbehov, mobile brukarar	Variabel anvendbarhet i ulike rom
<i>Personlege oppvarmings- og kjølesystem</i>	Spesielt relevant for kontor med open planløysing	Spesielt relevant for kontor med open planløysing		Utilstrekkeleg informasjon	Relevant for utsjekkings-skrankar og liknande arbeidsplassar	Relevant for utsjekkings-skrankar og liknande arbeidsplassar
<i>Lågtemperatur termisk oppvarming</i>		Avhengig av varmebehov og varmesystem			Utilstrekkeleg informasjon	Utilstrekkeleg informasjon

Konklusjonen inneheld anbefalingar om kva teknologiar som er lovande, for kva bygningstype dei eignar seg for og kvar avgrensingane er for kvar enkelt teknologi. Frå tabellen kan vi konkludere med at alle vurderte teknologiane er lovande for kontorbygningar (både nye og rehabiliterte). I tillegg til dei teknologiane som er nemnde i tabellen vurderast responsive lysanlegg, smart energistyring og utnytting av overskotsvarme som lovande for alle bygningskategoriar. Det er ynskjeleg at tekniske installasjonar nyttar lågtemperatur oppvarming og høgtemperatur kjøling for betre å kunne utnytte fornybare energikjelder og overskotsenergi, samt minke varmetap frå systema. Bygningsinstallasjonar i nye og renoverte bygningar bør ta sikte på ein optimalisering av energi, effekt og innemiljø. Ei omfattande tilnærming må til for å vurdere energiyting, komfortkvalitet og økonomisk gjennomføringsevne for lågenergi bygningstenester.

Utfordringar ved dei ulike teknologiane er identifisert og diskutert for dei ulike bygningstypene. Kapittel 14 presenterer anbefalt vidare arbeid for desse utvalde bygningsteknologiane for nullutsleppsområder. Desse områda vert nærare omtala i eit eige ZEN Memo.

## Summary

It is believed that well-performing building envelopes with low thermal losses and low solar heat gains enable simplified building services solutions. The purpose of this report is to summarize the status of promising building services solutions suitable for a low emission building stock in urban areas. The solutions are selected as relevant for use by the ZEN partners, the ZEN pilot areas and for further research in FME ZEN.

The table below shows for which building categories the discussed technologies are considered to be a promising solution (dark green), possibly promising solution (light green), or just might have a minor impact (yellow). Building categories where the technical solutions have not been evaluated are marked (0). The different technologies are presented in Part II and the table is elaborated in chapter 13.

<i>Building category / Technical solution</i>	<i>New offices</i>	<i>Renovated offices</i>	<i>Schools</i>	<i>Residential buildings</i>	<i>Grocery stores</i>	<i>Shopping centres</i>
<i>Demand-controlled ventilation</i>	Large saving potential with established technology, in particular open-plan offices and meeting rooms		Large saving potential with established technology	Needs adaptation to thermal zoning and more professional maintenance	Insufficient information	Insufficient information
<i>Ventilation-based heating</i>	Large saving potential with established technology	Depends on heating demand, windows, etc.		Unsuitable for bedrooms with lower temp. requirements	Floor heating, radiant heating or radiators are not practical solutions	Insufficient information
<i>Cooling by high air speed</i>			Adaptation to high occupant density needed	Needs adaptation to smaller airflows	Small room cooling loads, mobile users	Variable applicability in different spaces
<i>Personal heating and cooling devices</i>	In particular relevant for open-plan offices	In particular relevant for open-plan offices		Insufficient information	Relevant for check-out counters and similar workplaces	Relevant for check-out counters and similar workplaces
<i>Low temperature thermal heating</i>		Depends on heating demand and heating system			Insufficient information	Insufficient information

The conclusion includes recommendations on which technologies are promising, for which building categories they are suitable and where the limitations are for each technology. From the table we can conclude that all the technologies have proven to be promising for office buildings (both new and renovated). In addition to the technologies in the table, responsive lighting equipment, smart energy control, and utilization of surplus heat sources are considered promising for all building categories. Technical installations should utilize low-temperature heating and high-temperature cooling in order to better utilize renewable energy sources and surplus energy, and to reduce heat loss from the systems. Future building services in new and renovated existing buildings should aim for an optimization between energy, power, and indoor environmental performance. A comprehensive approach is needed for assessing energy performance, comfort quality, and economic feasibility of low energy building services.

Challenges of the different technologies are identified and discussed for the different building types. Chapter 14 presents relevant further work for the selected building services solutions for zero emission neighbourhoods. These areas are further discussed in a separate ZEN Memo.

## Contents

Preface .....	3
Samandrag.....	4
Summary .....	5
1 Introduction .....	11
PART I: Building types.....	12
2 Office buildings .....	14
2.1 Relevant projects .....	14
3 Schools and other educational buildings .....	15
3.1 Relevant projects .....	15
4 Residential buildings .....	15
4.1 Relevant projects .....	15
5 Grocery stores.....	16
5.1 Relevant projects .....	16
6 Shopping malls .....	17
6.1 Relevant projects .....	17
PART II Technologies.....	18
7 Demand controlled ventilation .....	18
7.1 Background .....	18
7.2 Recent projects .....	18
7.3 Potential.....	18
7.4 Limitations and need for further work.....	18
8 Cooling by high air speed.....	19
8.1 Background .....	19
8.2 Recent projects .....	19
8.3 Potential.....	19
8.4 Limitations and need for further work.....	20
9 Ventilation-based heating .....	20
9.1 Background .....	20
9.2 Recent projects .....	20
9.3 Potential.....	20

9.4	Limitations and need for further work.....	21
10	Personal heating and cooling devices .....	21
10.1	Background .....	21
10.2	Potential.....	22
10.3	Limitations and need for further work.....	22
11	Low temperature thermal heating.....	22
11.1	Background .....	22
11.2	Recent projects .....	22
11.3	Potential.....	23
11.4	Limitations and need for further work.....	23
Part III Discussion, conclusions and further work .....		24
12	Building services in a zero emission neighbourhood .....	24
12.1	Utilizing low-temperature energy sources including waste heat.....	24
12.2	Reducing energy demand for lighting .....	25
13	Applicability of researched technologies.....	26
14	Further work .....	26
15	References .....	29
16	Appendices .....	34
Appendix A: Demand control in schools and offices: BestVent.....		34
	Introduction .....	34
	Design criteria .....	35
	Conclusions and need for further work .....	36
Appendix B: Cooling by higher air speed: Svalvent.....		37
Appendix C: Ventilation-based heating: ForKlima.....		39
	Introduction .....	39
	Design criteria .....	39
Appendix D: Energy efficient grocery store: Kiwi Dalgård.....		42
	Description of technical solutions used at KIWI Dalgård.....	44
	Preliminary analysis and discussion.....	48
	Conclusions and need for further work .....	55
Appendix E: Climatization of residential buildings .....		57
	Temperature distribution in living areas (Q1).....	59
	Temperature differences between rooms (Q2).....	61
	Temperature in bedrooms and window opening (Q3).....	62



A holistic research project on highly-insulated houses (EBLE).....	64
Conclusions and need for further work .....	65
Appendix F: CommONEnergy: Shopping centres .....	68
Ventilative cooling .....	68
Thermal zoning.....	70
Concept of modular multifunctional façade .....	71
Green vegetation.....	71
Daylighting strategies.....	72
ICT systems platform .....	76
Interaction with local energy grid.....	77
Discussion .....	79
Conclusions and need for further work .....	80



## 1 Introduction

To achieve zero emission neighbourhoods, it is necessary to reduce the energy demand for individual buildings as well as use energy smartly on a neighbourhood scale. Well-performing building envelopes with low thermal losses and low solar heat gains and efficient heat recovery units in ventilation, may enable simplified building services to reduce investment costs. Indeed, the original German passive house definition demanded that the heat losses should be sufficiently small that the houses could be heated by ventilation air only, thereby "paying for" the extra insulation and airtightness by saving the costs of a heating system ([www.passiv.de](http://www.passiv.de)). Simplification of building services systems is still a viable option in many cases, but leaving out hydronic heating and cooling systems may not be the optimal solution, as this reduces the flexibility in energy supply and distribution between buildings in the neighbourhood.

This report compiles building services solutions studied in research projects familiar to the authors and that may be particularly suitable to reduce emission on a neighbourhood scale. Systems that satisfy at least one of the following criteria are included:

- solutions that moderate heating- or cooling power demand
- solutions fit for surplus energy sources
- simplified heating or cooling systems
- extremely low-temperature heating systems
- extremely high-temperature cooling systems

The suitability of the included systems is discussed in the context of the building categories new and renovated offices, educational buildings, residential buildings, grocery stores, and shopping centres.

This report is not intended to form an exhaustive literature or technology review but serves as an introduction to ZEN partners and researchers to relevant and recent research where points of contact are readily available in the ZEN research community. Results of a literature review concerning building services solutions in zero emission neighbourhood are currently under publication [2].

The first part of the report briefly introduces the building categories that have been studied and research projects related to these categories.

The second part describes the selected individual building services systems separately, and the third part discusses how these systems can contribute to reduced emissions on a neighbourhood scale. The discussion includes building service technologies not treated in the two previous parts but does not aim to fully cover the vast magnitude of emerging or present technologies that are relevant in this context.

More detailed information of the different projects referred to in parts I and II is given as appendices. Appendix F on the EU-project CommONEnergy includes a summary of an extensive review of technologies relevant for shopping centres, that are not treated elsewhere in this report, and that may be relevant also for other buildings.

## PART I: Building types

Buildings can be classified in several ways. NS 3457-3:2013 classifies buildings in a 3-digit coding system according to their main function. 126 of the codes at the three-digit levels are used in the Cadastre property register "Matrikkelen", from "111 Single-family house" to "840 public toilet". Within many of the categories a large range of building sizes, constructions, and energy demand profiles can be found.

In this report five categories are highlighted: office buildings, schools, residential buildings, grocery stores, and shopping malls. The categories are selected partly because they are examined in recent relevant projects and partly because they are common and important parts of many neighbourhoods. In this context "Office building" corresponds to category 31 in Matrikkelen, "School building" to 613-616, "Residential building" to 11-14, "Grocery store" to a subset of 322 if it is a free-standing building, and "Shopping mall" to 321 (which also can include a grocery store).

In Table 1, some assumed properties of the selected categories are highlighted. As input to the table, values from SN/TS 3031:2016 "Energy performance of buildings. Calculation of energy needs and energy supply" are used. These values are either included in the standard as guidance where information is incomplete, or to ensure common practice in documentation of compliance. Also, data from two reports published by NVE on the energy demand of non-residential buildings is included. Neither of these sources give accurate values for individual buildings, but the values are still relevant to highlight differences in energy profiles of individual buildings.

**Table 1. Assumptions for the highlighted building categories.**

	<i>Office</i>	<i>School</i>	<i>Residential</i>	<i>Grocery store</i> *	<i>Shopping mall</i> *																																																												
<b>Occupied hours (h/d/w)</b>	12/5/52	10/5/44	24/7/52	12/6/52	12/6/52																																																												
<b>Person load</b>	Low (to high in meeting rooms)	Mostly high to very high.	From very low to high.	Mostly low	Mostly low																																																												
<b>Activity levels</b>	Low to moderate	Low to high	Very low to high	Low to moderate	Low to moderate																																																												
<b>Adjustment of clothing</b>	Restricted freedom to adjust	Somewhat restricted	Large freedom to adjust	Restricted. Often adapted to outdoor (customers).																																																													
<b>Estimated specific demand (kWh/m<sup>2</sup> per year) (NVE 2014 and 2016, TEK 17)</b>	<table border="1"> <caption>Estimated specific demand (kWh/m<sup>2</sup> per year) by building category</caption> <thead> <tr> <th>Building Category</th> <th>Heating</th> <th>Cooling</th> <th>Ventilation</th> <th>DHW</th> <th>Lighting</th> <th>El. Specific</th> <th>Tenant el</th> <th>Central cold store</th> <th>Plug-in cold store</th> </tr> </thead> <tbody> <tr> <td>Office</td> <td>~70</td> <td>~10</td> <td>~10</td> <td>~10</td> <td>~20</td> <td>~40</td> <td>~0</td> <td>~0</td> <td>~0</td> </tr> <tr> <td>School</td> <td>~100</td> <td>~10</td> <td>~10</td> <td>~10</td> <td>~10</td> <td>~20</td> <td>~0</td> <td>~0</td> <td>~0</td> </tr> <tr> <td>Residential...</td> <td>~30</td> <td>~10</td> <td>~10</td> <td>~10</td> <td>~10</td> <td>~10</td> <td>~0</td> <td>~0</td> <td>~0</td> </tr> <tr> <td>Grocery store</td> <td>~10</td> <td>~10</td> <td>~10</td> <td>~10</td> <td>~100</td> <td>~50</td> <td>~0</td> <td>~150</td> <td>~30</td> </tr> <tr> <td>Shopping mall</td> <td>~80</td> <td>~10</td> <td>~10</td> <td>~10</td> <td>~10</td> <td>~20</td> <td>~50</td> <td>~0</td> <td>~0</td> </tr> </tbody> </table>					Building Category	Heating	Cooling	Ventilation	DHW	Lighting	El. Specific	Tenant el	Central cold store	Plug-in cold store	Office	~70	~10	~10	~10	~20	~40	~0	~0	~0	School	~100	~10	~10	~10	~10	~20	~0	~0	~0	Residential...	~30	~10	~10	~10	~10	~10	~0	~0	~0	Grocery store	~10	~10	~10	~10	~100	~50	~0	~150	~30	Shopping mall	~80	~10	~10	~10	~10	~20	~50	~0	~0
Building Category	Heating	Cooling	Ventilation	DHW	Lighting	El. Specific	Tenant el	Central cold store	Plug-in cold store																																																								
Office	~70	~10	~10	~10	~20	~40	~0	~0	~0																																																								
School	~100	~10	~10	~10	~10	~20	~0	~0	~0																																																								
Residential...	~30	~10	~10	~10	~10	~10	~0	~0	~0																																																								
Grocery store	~10	~10	~10	~10	~100	~50	~0	~150	~30																																																								
Shopping mall	~80	~10	~10	~10	~10	~20	~50	~0	~0																																																								

\*) SN/TS 3031:2016 only provides a single value for "commercial buildings"

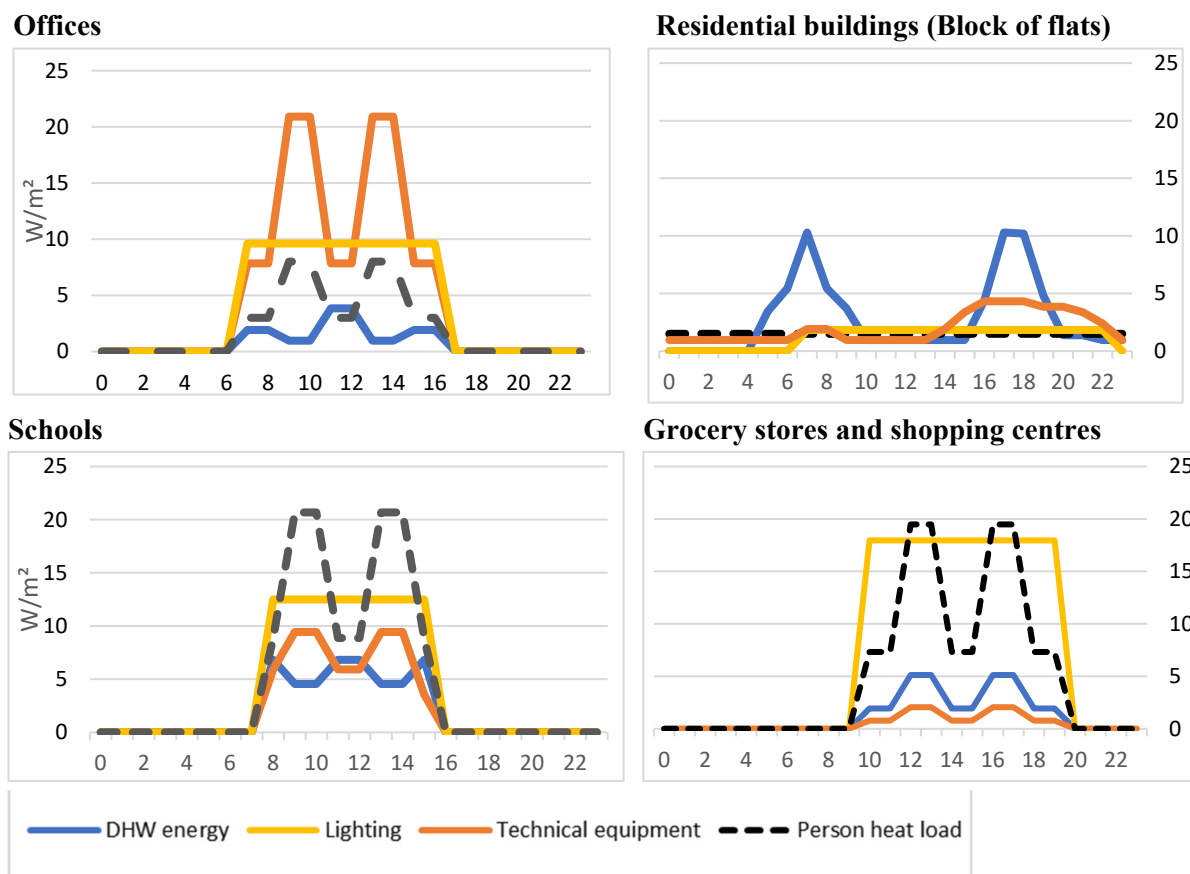

Figure 1. Load profile according to SN/TS 3031:2016.

## 2 Office buildings

Office buildings are characteristically used only in the daytime. The total person load in the building is normally low, but is typically highly variable in meeting rooms, lunchrooms, etc. Flexible floorplans are high in demand, and internal remodelling can be quite frequent. Open-plan office spaces, particularly with free seating, poses challenges to accommodate for individual preferences. Physical activities are low to moderate for the majority of the users, and adjustment of clothing is somewhat restricted by formal or informal dress codes.

### 2.1 Relevant projects

**ForKlima** (Forenklet behovsstyrt klimatisering av kontorbygg med svært lavt oppvarmingsbehov), 2013-2016 examined possibilities for simplifying climatization of office-buildings with small heat losses by heating with ventilation air. The project was financed by The Research Council of Norway, GK, Norconsult, Multiconsult, COWI, Trox Auranor, Statsbygg, Link Arkitektur and led by SINTEF. Information is available at <https://www.sintef.no/projectweb/for-klima/>.

**Svalvent** (Sval og behagelig behovsstyrt ventilasjon for individuell kjøling i yrkesbygg) 2017-2020 develops solutions for individual, user-controlled cooling via ventilation air. The project is financed by The Research Council of Norway, GK, Trox Auranor and Topro Industrier. Some information is available at <https://www.sintef.no/projectweb/svalvent/>.

### 3 Schools and other educational buildings

Educational buildings encompass a variety of buildings and locales with quite different usage. Most of the attention in the referenced projects focuses on classrooms in school buildings. Buildings for universities and vocational training will have quite different use patterns, commonly with laboratories and workshops where ventilation needs and heating loads from equipment may resemble industry and healthcare buildings closer than schools for smaller children.

School buildings are primarily used in the daytime on weekdays but may have secondary usage in evenings or weekends. The person load is mostly high and variable – up to 1 person per 2 m<sup>2</sup> in classrooms, and even denser in auditoria. Physical activities vary from low to high, and adjustment of clothing is common within certain limits.

#### 3.1 Relevant projects

**reDuCe ventilation** (Reduced energy use in Educational buildings with robust Demand Controlled Ventilation) 2010-2013 studied solutions for demand controlled ventilation. Financed by The Research Council of Norway, VKE, Skanska, Undervisningsbygg Oslo KF and Optosense, led by SINTEF.

Recommendations are published. Information and project results are available from <https://www.sintef.no/projectweb/reduceventilation/>.

**Best Vent** (BEST demand-controlled VENTilation strategies to maximize air quality in occupied spaces and minimize energy use in empty spaces) 2016-2019 examines strategies for controlling ventilation in schools and office buildings. The majority of the experimental and simulation work focuses on classrooms. Financed by The Research Council of Norway, Undervisningsbygg Oslo KF, GK, DnB Eiendom, Interfil, Camfill Norge, Erichsen & Horgen, Hjellnes Consult, Multiconsult, Swegon, Belimo Automasjon Norge, NEAS, Norsk VVS Energi- og Miljøteknisk Forenings Stiftelse for forskning. The project is presented at <https://www.sintef.no/prosjekter/best-vent/>.

### 4 Residential buildings

Dwellings are the most variable building category in terms of usage and load profiles among those treated in this report. This is due to different demand of dwellers in relation to habits and health, age and occupational status. To achieve satisfactory thermal and air quality comfort it is common to adjust clothing and open windows. Professional maintenance and operation is not customary. Usually the heat load and ventilation demand shifts within each dwelling between day and night.

#### 4.1 Relevant projects

The Norwegian research centre **ZEB** (<https://www.zeb.no/index.php/en/>) 2009-2016 performed several studies supported by PhDs, Postdocs, and several researchers [3]. The PhD work of Magnar Berge investigated the indoor environment in highly-insulated residential buildings [4]. The research method was based on field measurements, user questionnaires as well as detailed dynamic simulations. In general, ZEB performed exhaustive research about the indoor thermal environment of highly insulated buildings using a simplified space heating distribution combined with a centralized one-zone ventilation. This is the standard HVAC configuration in highly insulated residential buildings. These studies focused

on simplification using radiators, air heating, and wood stoves as well as thermal zoning, especially in bedrooms, and window opening during the space heating season.

**EBLE** (Evaluering av boliger med lavt energibehov) 2012-2016 evaluated 64 passive house dwellings and ten TEK 10 dwellings to increase the knowledge about residential buildings on passive house and near zero energy level. Financed by The Research Council of Norway, Skanska Norge, OBOS, Jadarhus Gruppen, Fjogstad-Hus Eiendom, Veidekke Entreprenør, Block Watne, Mestergruppen, Heimdal Bolig, Boligprodusentenes Forening and Lavenergiprogrammet (project owner), and with SINTEF as research partner. An open-access summary report is available [5].

**4RinEU** (2016-2021) is an EU H2020 financed project that aims to develop robust and reliable technology concepts and business models for triggering deep renovation of residential buildings in Europe. The project team coordinated by Eurac Research is composed by SME manufacturers, service companies, builders and consultants, as well as research institutions, in total 13 partners from six European countries. SINTEF is research partner in the project, and Haugerudsenteret, a 2-floor apartment building owned by Boligbygg Oslo KF, is one of three demo cases. The 1970'ies building was renovated to a high energy standard building using prefabricated elements with an integrated PV and ventilation system. For the Spanish demo, smart ceiling fans are tested for cooling by higher air movement, and an energy hub will be developed for the Dutch demo. More information is available at [www.4rineu.eu](http://www.4rineu.eu).

## 5 Grocery stores

Grocery stores are characterized by their large amounts of refrigerated or deep-frozen zones, many of which need access from the shopping area. There is also a need for effective lighting. This leads to very high area-specific energy demands and a heat excess that can be utilized for low temperature district heating or similar purposes. The assumed values for commercial buildings in SN/TS 3031 seem to have little relevance for grocery stores, as the cooling demand for goods clearly is present outside of opening hours.

The traffic of customers and delivery of goods leads to quite high and variable infiltration of air. Users have limited possibility to adjust clothing, and customers will often wear clothes adapted to outdoor weather.

### 5.1 Relevant projects

**SuperSmart** is an EU project (2016-2019) to speed up the uptake of more energy-efficient refrigeration, heating, and cooling solutions for Europe's food retail sector by reducing its energy use, lowering its environmental footprint, and increasing its economic benefits. Project partners are shecco, Umweltbundesamt, Technische Universität Braunschweig, International Institute of Refrigeration, CIRCE, ITC-CNR, Energija and KTH, and it is led by SINTEF. Financed by Horizon 2020 The EU Framework Programme for Research and Innovation. More information is available from <http://www.supersmart-supermarket.info/>.



**KIWI Dalgård** in Trondheim is a new innovative grocery store built by Norgesgruppen Eiendom, and received financial support from Enova SF. Technical systems include utilization of heat from freezing and cooling for heating ventilation air. Energy from heat recovery, heat pumps, and solar cells is exported to neighbours, stored in batteries or boreholes, or used for charging of vehicles. A presentation from the technical entrepreneur Caverion is available at: <https://events.provisoevent.no/websites/df26ac52-6e93-4ddb-a594-ccf2c5435a5e/3784f17b-d1ff-4d2d-a7e4-ce0be20ba6c7.html> (presentation number 7) [6].

## 6 Shopping malls

Shopping malls are often large and relatively complex buildings, where individual shops (tenants) manage and pay for lighting, cold storage, and other technical equipment. The intensity and quality of lighting is important for many of the tenants, often leading to high el-specific energy use.

The traffic of customers and delivery of goods lead to quite high and variable infiltration of air. Users have limited possibility to adjust clothing, and customers may wear clothes adapted to outdoor weather.

### 6.1 Relevant projects

**CommONEnergy** (2013-2017) was an EU-funded project aiming at turning shopping centres into temples of energy conservation and high indoor environmental quality. It gathered 23 partners representing various industry stakeholders, as well as research and academia from ten European countries. The shopping centre City Syd in Trondheim was one of the demonstration cases, and SINTEF was a research partner in the project. Information and project results are available from <http://www.commonenergyproject.eu/>.

## PART II Technologies

### 7 Demand controlled ventilation

#### 7.1 Background

The amount of ventilation necessary to maintain good IAQ (indoor air quality) in a room depends on the strength of the pollution from interior surfaces, furniture, and occupants. These pollution sources are either stationary or variable. The variable sources are mainly users and user-related activities, and in intensely used premises with low-emitting materials, the variable sources dominate the pollution and the ventilation needs.

The purpose of demand controlled ventilation (DCV) is to continuously adjust the ventilation rate to the current demand. The potential benefits and practical implications of DCV has been studied in a range of SINTEF projects. Important results have been published as practice-oriented reports and guidelines [7, 8]. DCV contributes to energy savings in buildings, as well as increased thermal comfort by reduction of over-ventilation. Current technology with active supply air devices, DCV dampers, and control systems enable real time and precise regulation of airflows based on sensor signals at room level according to actual use.

#### 7.2 Recent projects

The project 18educe ventilation analysed the energy saving potential of demand controlled ventilation in schools and developed guidelines for more robust design and commissioning of such systems, while Best Vent (see Appendix A) delves into the details of ventilation needs according to differences in materials, user age groups, interaction with outdoor air, and the relationship between temperature, humidity, and perceived air quality.



**Figure 2. Testing of comfort and performance by different ventilation strategies in the Best Vent project. Foto: SINTEF**

#### 7.3 Potential

DCV has energy saving potential in all spaces with variable ventilation needs. Such spaces are present in most building categories, even if the savings may be insufficient to finance the costs, where energy saving potential is small. Demand control ventilation is necessary to reach energy demands for most new buildings.

#### 7.4 Limitations and need for further work

Important limitations for DCV use are the costs of installing and maintaining the necessary control units and the ability to monitor the ventilation demand in situations where temperature and carbon dioxide are insufficient indicators. Development of sensors and control algorithms that more accurately correlate with perceived air quality and health relevant components in the air can increase the potential benefits

of using DCV. This will also make the technology a viable option in more special building categories, such as nursing homes, shops, or workshops.

The most common DCV solutions do not allow personal control to any large degree, and a significant proportion of users will remain dissatisfied with the thermal conditions without such, as reflected in NS-EN 15251:2007+NA:2014. Thermal indoor climate class I can only be achieved by individual demand-control. Combining demand-controlled ventilation with improved possibilities of controlling air velocity, such as in SvalVent, local temperature control of the supply air, or personal heating and cooling devices, can lead to improved energy-efficiency and users that are highly satisfied with the air quality and thermal environment. Some solutions can provide user-specific supply air rate and temperature, but commonly adjusted by maintenance personnel. Further development both on technical aspects and user interface is needed to achieve realtime individual control.

## 8 Cooling by high air speed

### 8.1 Background

In the classical theoretical model of thermal comfort, air movement is mainly seen as a source of discomfort, based on experiments with persons in neutral thermal condition. However, at elevated temperatures, when persons are in slightly warm condition, air movement can be regarded as refreshing. Ceiling, floor, or desktop fans are commonly used to increase thermal comfort in hot environments. Small air jets for individual control are already standard in cars or airplanes. Individual control allows for a general slightly higher indoor temperature and thereby less energy needed for cooling and potentially more satisfied users. Controllable jets integrated in the ventilation systems are emerging as an interesting technology for air-based heating and cooling and reduced investments for cooling systems.

### 8.2 Recent projects

The project Svalent studies the potential of utilizing controllable air jets integrated in supply air terminals for improving thermal comfort in open-plan offices. Further details are given in appendix B. Use of smart ceiling fans with advanced control algorithms for residential cooling is studied in the 4RinEU project.

### 8.3 Potential

Controllable jets as developed in SvalVent are potentially useful where users are more or less stationary, e.g. by an office desk, at checkout desks, or possibly even in a hospital bed. Individual control by app



**Figure 3. Measurements of skin temperatures in SvalVent are important for better understanding of the effect of cooling air speed on comfort and satisfaction. Photo: SINTEF**

and wireless connections makes this a potential attractive market solution with real time individual adjustments.

#### 8.4 Limitations and need for further work

Long term satisfaction by different user groups is currently studied. No fully tested solutions for highly mobile users are currently available.

## 9 Ventilation-based heating

### 9.1 Background

Heating through ventilation air is described at least from the 13<sup>th</sup> century, and principles described in detail in the early 1800s (see Figure 4). However, in buildings with large heat losses, quite large ventilation rates and/or high supply air temperatures are necessary to maintain desired temperatures. This easily results in unsatisfactory thermal conditions (hot head and cold feet), low air change efficiency, bad perceived air quality, and drying of eyes and skin. In buildings with low heating demand, only slightly overheating of the supply air is necessary, and thereby the premises are considerably improved. Ventilation-based heating is an attractive option for simplification of the heating system.

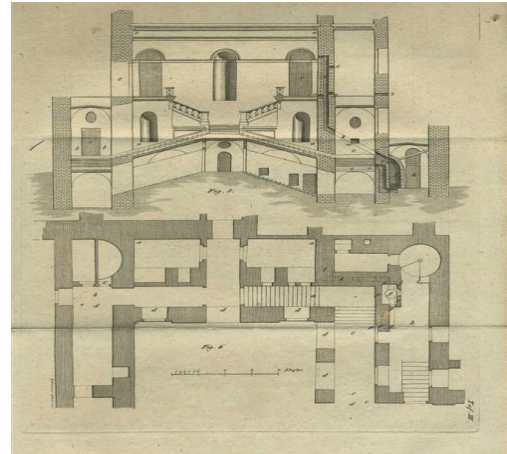

Figure 4. Principles for ventilative heating were described in 1823 [1].

### 9.2 Recent projects

The project ForKlima (see Appendix C) concluded that the solution is suitable for office spaces with low heating demand. CFD-calculations, field measurements, and user queries confirmed that thermal comfort and air change efficiency could be maintained even on cold days in a new energy-efficient office building and that some personal temperature control was possible. Only isotherm or slightly over tempered supply air was necessary during workhours [9].

Several of the dwellings evaluated in the project EBLE (Appendix E) had bedrooms that in practice were heated by supply air only, due to the high extract air temperatures and efficient heat recovery.

### 9.3 Potential

Ventilation heating solutions are documented as suitable for energy efficient new office buildings and are applicable also for office areas in other building types (e.g. educational buildings, healthcare buildings, or commercial buildings). They can also be used in well-insulated existing buildings. Key premises for success are low heating demand and documented characteristics of the inlet valve.

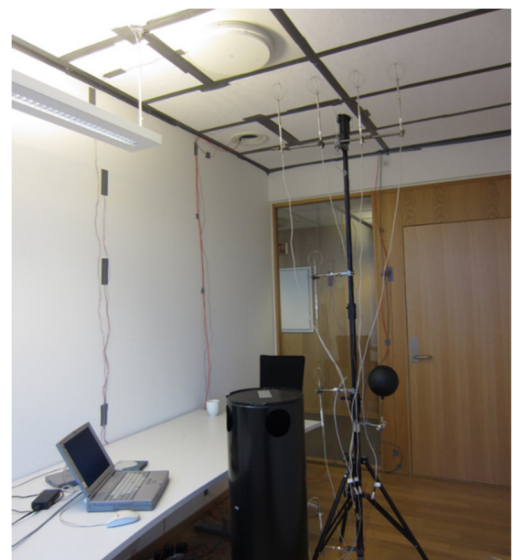

Figure 5. Test of ventilative heating in ForKlima. Photo: SINTEF.

## 9.4 Limitations and need for further work

ForKlima documented satisfied users with isothermal to 2 °C overheating of supply air in passive house office buildings. More research on design limitations, especially for energy efficient deep renovation and air inlet characteristics, is recommended. Solutions suitable for combined heating and cooling by ventilation is of interest, as well as improved individual control.

Too large variation in temperature preferences in spaces served by the same ventilation unit may limit the applicability of ventilation-based heating (or cooling). As an example, ventilation-based heating may not be generally suitable for dwellings where bedrooms have relatively high ventilation requirements but often lower preferred temperatures than living rooms and bathrooms.

Hydronic systems or small electric heaters integrated in air inlets allow for larger span in individual or local preferences but complicates the system. The cost of these more complex systems may be defendable where floorplan flexibility is a priority.

Increased air volumes and air temperature will add to problems connected to low relative humidity, and it is recommended to research possibilities to alleviate this, e.g. moisture recovery, heating outside operating hours or heating with recycled air (when users are absent).

## 10 Personal heating and cooling devices

### 10.1 Background

Traditionally, heating and cooling systems in buildings have been designed to make *most* people satisfied with their thermal environment. Fanger's model is commonly used for describing thermal comfort, but it concludes that for large groups identically dressed and with the same activity level, there will always be someone dissatisfied. Personal heating and cooling devices, such as for instance heated and cooled chairs, seem promising for making more, if not all, users satisfied with their thermal environment. Heated seats are commonly used in vehicles (see Figure 6). A literature study [10] found



**Figure 6. 1966 Cadillac Seville was among the first cars to introduce heated seats. Photo: Sicnag via Wikimedia Commons.**

personal heating and cooling devices to significantly improve thermal comfort for the users. The use of personal heating and cooling devices also made it possible to achieve thermal comfort outside the traditional heating and cooling setpoints, thus making it possible to extend the thermal dead-band of buildings. Applying the energy only where it is actually needed with low-power solutions could lead to substantial energy savings compared to traditional HVAC systems operated around 21-22 °C. The use of such solutions will enhance the possibility of using low temperature heating systems, high temperature cooling systems as well as simplified distribution systems for heating and cooling.

## 10.2 Potential

Personal heating and cooling devices are suitable for improving user satisfaction in office buildings, especially in open landscapes, where there are many users with different thermal preferences within the same thermal zone. It is notable that the use of personal heating devices to avoid local thermal discomfort also can increase perceived air quality and save energy, as the air temperature can be lower.

## 10.3 Limitations and need for further work

The solutions might be relevant for educational buildings as well but is probably more suitable for students at higher education instead of children in elementary school.

Grocery stores, shopping centres, and different healthcare buildings have not been evaluated, but such solutions could be highly relevant for these buildings. Indoor temperatures adapted to walking customers wearing outdoor clothing or hospital staff performing physical work are considerably lower than comfortable for a sitting office attendant or a resting patient. Personal heating devices could be adaptable for the latter.

Some users in residential buildings might be interested in using such devices, however, in residential buildings, the users also have the possibility to change their clothing level to adapt to their thermal environment. For kindergartens it is not at all relevant for the children but could be relevant for the employees in the offices.

# 11 Low temperature thermal heating

## 11.1 Background

Hydronic systems for space heating are well-proven and energy flexible, but traditional radiator systems are relatively costly in installation and reduces floorplan flexibility. Floor heating systems are even more costly and responds slowly to changes in heating demand. Thus, in buildings with low heating demand, simplification of hydronic heating systems is attractive. Also, when converting existing buildings from electric to thermal heating, simplification and cost reduction is crucial.

Simplified space heating distribution has been investigated in the context of highly insulated residential buildings. The configuration of the heating and ventilation considered in these researches is the most representative of Norwegian passive houses: a centralized balanced mechanical ventilation with a single air supply temperature for all the rooms (so-called one-zone ventilation) and using a cascade flow while, in the case of radiator heating, one heat emitter is placed for each floor.

## 11.2 Recent projects

LTTG+ (2018-2020) will develop smart heating solutions for new urban areas: local low-temperature district heating grids which utilize nearby surplus heat sources. Industrial partners are Statkraft Varme, Fortum Oslo Varme, Trondheim Municipality, Koteng Eiendom, and Gjøvik Kommune, while research partners are SINTEF Energy Research, SINTEF Community, NTNU EPT, and NTNU ITK. Brief information is available at <https://www.sintef.no/prosjekter/lttg/>.

EBLE (Appendix E) evaluated some dwellings heated by a single hydronic heater per apartment.

### **11.3 Potential**

In buildings with small heat losses and without the need for heat sources under windows, hydronic heating systems can be designed in a number of ways, some also capable of providing hydronic cooling. Low-temperature thermal grids combined with low-cost heat emitters allows for exploitation of a range of energy sources including excess heat sources and taking heating loads off the electricity or high-temperature thermal grids. Such systems are interesting for heat supply of most building categories, and for grocery stores, server parks, or other potential suppliers, also interesting for exporting heat.

Previous research works have documented and explained the temperature distribution inside the building generated by the simplified space heating distribution, both in terms of temperature differences between rooms but also in the temperature distribution inside the room equipped with the heat emitter. The main conclusions from these studies show that the indoor thermal environment of living areas is experienced as comfortable by occupants. The most critical part is related to the thermal comfort in dwellings, where it is challenging to maintain the wanted temperature differences between bathroom, living room, and bedroom. For more information, see Appendix E.

### **11.4 Limitations and need for further work**

Low-temperature heating (and high temperature cooling) have a relatively long response time, and if the systems are simplified with few heat emitters, allowing for temperature variation between adjoining spaces can also be challenging. To achieve thermal comfort, predictive control of the system could be significantly better than responsive (e.g. thermostat) control, especially in the presence of other fast-changing heat sources (e.g. users, lighting or equipment). In some situations, it may even be rational to sacrifice some overall energy efficiency by using the fast responding ventilation system to remove some excess heat provided by a slow-reacting hydronic system operating from a very low-emission heat source. This, however, presupposes a quite sophisticated level of energy source management.

## Part III Discussion, conclusions and further work

### 12 Building services in a zero emission neighbourhood

To achieve zero emission on a neighbourhood scale, energy demand and power peaks of the individual buildings should be very low. Building services solutions discussed in part II, such as demand-controlled ventilation, cooling by high air speed etc., aim to reduce the energy demand. Other technologies contribute to the same. This includes e.g. utilization of daylight, smart and energy-efficient lighting systems, night heating or cooling of the thermal mass in the building, zoning the ventilation systems to minimize simultaneous heating and cooling needs, as well as the now common procedures to minimize thermal losses through the building envelope. However, a neighbourhood consists of buildings with different energy demand profiles. Existing buildings may be very costly or practically impossible to renovate to energy demands approaching net zero energy buildings due to technical limitations, regulations, or preservation of cultural value. In this perspective, it is necessary to evaluate building services solutions according to their effect on the annual energy use, but also to consider the effect of each building on the total energy demand profile of the neighbourhood. Local energy distribution, storage, local renewable energy production, and energy export are also part of this picture.

#### 12.1 Utilizing low-temperature energy sources including waste heat

While multiple buildings in Norway are utilizing surplus heat from various cooling processes, large amounts of thermal energy are released to the environment as "waste" or surplus heat. Valuing waste as a resource is a prerequisite for a circular economy and should apply for energy as well as for materials. In order to make such a transition, a good match between the source of surplus energy and the demand for heat is important. Examples of relatively constant, and thus attractive, heat sources are refrigeration systems in grocery stores, cooling of computer servers [11], or industrial process cooling. Attempts are being made to convert process heat to electricity (Copro, <https://www.sintef.no/prosjekter/copro/>) or high temperature media (HeatUp, <https://www.sintef.no/prosjekter/heatup/>), but investment costs and energy losses will generally be much smaller if the energy can be utilized at low temperatures.

Almost all buildings have at least some theoretical potential for utilizing surplus heat for (pre)heating of domestic hot water or space heating, while the availability for surplus heat for export is mainly present where there are significant cooling loads, extract airflows that cannot be efficiently recovered, hot wastewater, etc. Loads for cooling and freezing food, process cooling, and computer/telecom cooling are relatively constant throughout the year and are thus considered to be very good and reliable sources for surplus heat. Seasonal sources such as space cooling of buildings are more challenging to match with demands.

Recovered heat is most easily used for a demand that is relatively stable throughout the year, such as preheating of domestic hot water. Short term mismatches can be alleviated by storage tanks, phase-change materials or thermal mass in buildings, and storage through brine circuits in rock or ground can provide some long-term storage.

Mapping of load and supply profiles on a neighbourhood scale should preferably be performed in an early design phase. Power duration curves, such as illustrated in Figure 7, is a useful tool, but there is a need for improving tools as well as business models for utilizing surplus heat on a neighbourhood scale.



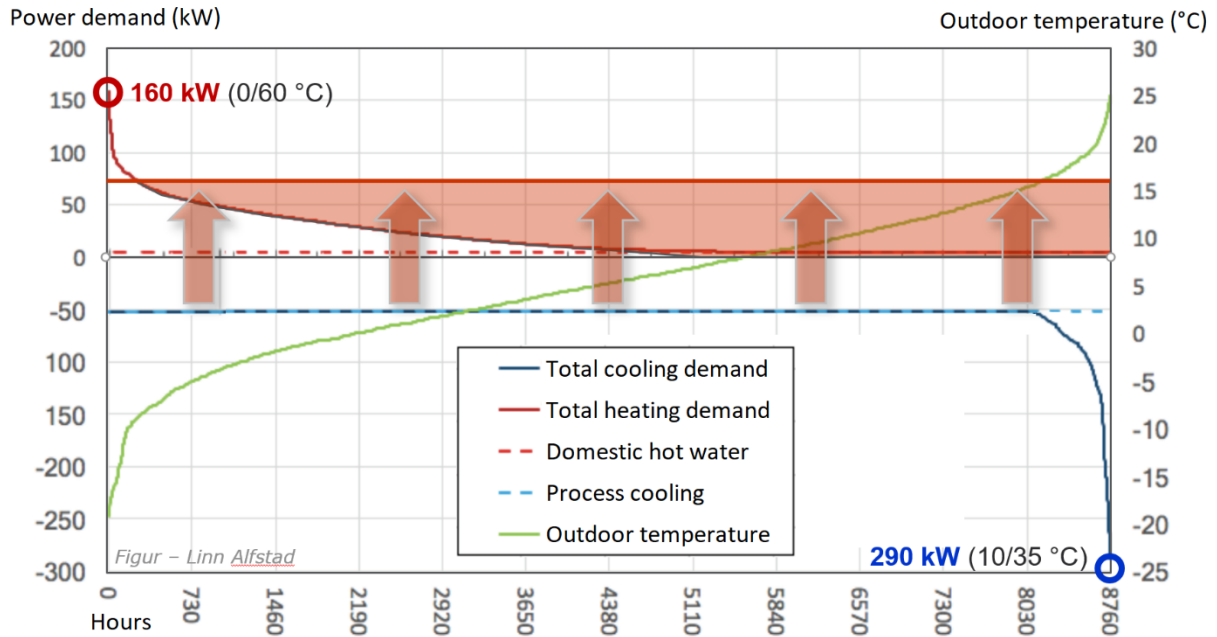

**Figure 7** Example of duration curve with good match between process cooling at Otto Nielsens vei 12E and heating demand for Otto Nielsens Vei 12A-D in Trondheim. More information can be found in a master thesis analysing the thermal energy system for the building [12].

In addition to reducing heat loss during wintertime, better insulated buildings have also extended the duration of the cooling seasons. The cooling demand is highest during periods with high outdoor temperature or high solar heat gains. Passive measures, such as reducing the solar heat gain through exterior solar shading, should be utilized before active measures. Smart control of the building, utilizing thermal mass, or night cooling through window opening or ventilation are also viable options. Among the active measures, ground source and seawater heat pump systems provide very efficient cooling systems, through utilization of "free cooling", as the temperature of the heat source is sufficiently low to cool the building using only the circulation pumps (unlike air-source heat pumps). These systems are especially relevant for large office buildings with both heating and cooling demands. The cooling process will also benefit ground source heat pump systems by balancing the thermal loads and "recharging" the boreholes, leading to higher COP during wintertime than for buildings with only heating demand.

## 12.2 Reducing energy demand for lighting

As illustrated in Table 1, artificial lighting adds significantly to electricity demand and internal heat gains. The development within light emitting diodes (LED) facilitates more efficient conversion of electrical energy into light compared to incandescent or fluorescent lamps, but also enables colour or hue and intensity to be controlled. Changing luminaires to LED will by itself reduce energy demand and heat loads. Responsive systems that adapt artificial lighting to the amount of available daylight adds further to energy efficiency. It is particularly important to reduce the lighting heat loads in situations with cooling demand: typically, when bright sun adds to the heating loads of the building.

Exploitation of daylight to cover portions of illuminance saves energy and has potential health benefits. Responsiveness of the artificial lighting to unleash these potential benefits is, however, not as simple as turning down or off artificial light as a response to available daylight. The human eye is able to adapt to

varying luminance, but only to a limited range at any given time. Thus, it may be necessary to turn at least some artificial lighting *up* as a response to bright daylight coming in from a window. The effect and control regime of artificial and natural lighting are of consequence for heating and cooling and should be planned and sized before heating and cooling equipment is dimensioned.

### 13 Applicability of researched technologies

In this section we have evaluated the applicability of the different technologies in Part II for the building categories in Part I. The technologies are often developed or tested within one specific building type. Some assumptions and prerequisites are explained that will make these technologies also suitable for other building types.

Table 2 shows where the discussed technologies are considered to be a promising solution (green), possibly promising solution (light green) or just might have a minor impact (yellow). Building categories where the technical solutions have not been evaluated are white.

**Table 2 Overview of technical solutions and their suitability for different building categories.**

<i>Building category / Technical solution</i>	<i>New offices</i>	<i>Renovated offices</i>	<i>Schools</i>	<i>Residential buildings</i>	<i>Grocery stores</i>	<i>Shopping centres</i>
<i>Demand-controlled ventilation</i>	Large saving potential with established technology, in particular open-plan offices and meeting rooms		Large saving potential with established technology	Needs adaptation to thermal zoning and more professional maintenance	Insufficient information	Insufficient information
<i>Ventilation-based heating</i>	Large saving potential with established technology	Depends on heating demand, windows, etc.		Unsuitable for bedrooms with lower temp. requirements	Floor heating, radiant heating or radiators are not practical solutions	Insufficient information
<i>Cooling by high air speed</i>			Adaptation to high occupant density needed	Needs adaptation to smaller airflows	Small room cooling loads, mobile users	Variable applicability in different spaces
<i>Personal heating and cooling devices</i>	In particular relevant for open-plan offices	In particular relevant for open-plan offices		Insufficient information	Relevant for check-out counters and similar workplaces	Relevant for check-out counters and similar workplaces
<i>Low temperature thermal heating</i>		Depends on heating demand and heating system			Insufficient information	Insufficient information

### 14 Further work

In this section we provide recommendations for further work on building services for zero emission neighbourhoods, either within the FME ZEN framework or in a wider context. Some further elaboration

of the ideas and suggestions for future research and development are given in a separate internal document, available to ZEN partners.

From Table 2 we can conclude that all technologies we focused on have proven to be promising for office buildings (both new and renovated). In addition, chapter 12 introduces the importance of utilizing excess heat and reducing the electrical energy and heat loads from lighting.

It has repeatedly been uncovered that the optimization across systems, buildings, and organization necessitates better methods for modelling, predicting, and controlling the behaviour of the individual systems and the resulting indoor environmental parameters.

Thus, building automation systems as well as tools for modelling and prediction are highlighted as common fields of development, along with development within the different building services systems.

Specific needs for further work regarding building services solutions are listed below:

- For successful implementation of *demand-controlled ventilation*, it is important to focus on planning with the correct air volumes and the appropriate ventilation strategies. The technology is already useful for offices, educational buildings, and kindergartens, but could also be considered for other building categories with variable ventilation demands. Present indicators of air quality should be improved.
- *Cooling by high air speed* is gaining more importance in buildings with high internal gains, such as offices and shopping centres. More focus should be put on utilizing this technology in educational buildings, kindergartens, dwellings, and grocery stores.
- *Ventilation-based heating* is very promising for highly insulated buildings, but it has most extensively been evaluated for office buildings.
  - Solutions allowing different supply air temperatures in different rooms of dwellings should be developed and tested by users.
  - Dry air during the heating season and periodically low relative humidity in indoor air is a general problem occurring in all new buildings with balanced mechanical ventilation systems. One possible solution for increasing the relative humidity in indoor air is to lower the air exchange during particularly cold periods. Such a reduction of the air exchange can also reduce energy consumption for heating ventilation air during cold periods but may not be possible where supply air is relied upon for heating. More suggestions can be found in the internal ZEN memo *Technical concepts to avoid low relative humidity* (available to ZEN partners and on request to non-ZEN partners)
- *Personal heating and cooling devices* are promising technologies for increasing users' satisfaction with their thermal environment. If the setpoints of the traditional heating and cooling system are extended accordingly, it also represents a large potential for energy savings.
  - The solutions are most suitable for offices, especially open landscapes, where individuals within a group have different thermal preferences. Another application could be in buildings where the users have different activity levels or clothing levels, for instance staff sitting still in a cashier in grocery stores or shopping centres.
  - Personal heating and cooling devices are also expected to be suitable for combination with low-temperature heating systems and high-temperature cooling systems, as well as for simplified distribution systems for heating and cooling.
- Regarding *low temperature thermal heating*,
  - issues related to temperature zoning need to be resolved, particularly in dwellings.

- improved control procedures, most likely using predictive control, can improve user satisfaction and optimize energy use.
  - simplified distribution systems (e.g. one large, centrally placed radiator) have proven to provide satisfactory thermal comfort in highly insulated residential buildings, but should be investigated for other building categories.
  - business models for trading thermal energy between buildings (and different owners) should be developed, as well as procedures for optimal design and operation.
- *Improved tools for the dynamic modelling and prediction of demand and supply of heating, cooling and electricity* would be enablers for efficient design of building services. With dynamic simulations, it is possible to account for the different parts of a building, such as the envelope and different zones, natural and mechanical ventilation, lighting, refrigeration, and Heating Ventilation and Air Conditioning (HVAC) systems, as well as their interconnections. In more complex systems, more advanced theoretical modelling and dynamic energy simulations can help to assess energy efficiency improvement, system functionality, and comfort quality of the overall building or of parts of it. Appropriate tools are very useful both in design, commissioning and operation of a building.
    - However, the number of input values necessary to achieve sufficient resolution in time and space is vast, and some of these input variables – such as user behaviour - are stochastic by nature. Development of tools that are able to handle stochastic variables in an efficient way as well as improved data sets on user behaviour and building response is needed in order to fully exploit the possibilities of building simulation. It is likely that a combination of physical and data-driven models is needed.
    - Once the model of the whole system is developed, the control strategies for managing the building and optimizing the systems can be implemented and tested. Numerical models and energy dynamic simulations will also have a growing role during the operational phase. It will be possible to use the model for optimizing the operation, for developing controls (model predictive controls), for fault detection, and for exploiting artificial intelligence (such as machine learning) of the systems (digital twin).
  - The *building automation system (BAS)* plays an important role in making use of the promising potential of many technologies. A smart BAS that takes predicted usage, weather, and energy price into account, may optimize the operation of these systems and utilization of energy storage (accumulator tanks, batteries) or import / export (charging of vehicles, choice of energy carrier, electricity export to grid). Also, integrated control of parameters for Indoor Environmental Qualities (IEQ) can make the BAS even smarter.

Some building types (especially residential buildings) have less focus on BAS, mainly due to cost-benefit assessments. However, cost reduction on components, communication, data storage, and almost universal access to smartphones, indicates that BAS for the residential market can become common. Development of more user-friendly systems, and possibly new services built on such systems, is recommended with the residential market as a target.

- *Responsive lighting equipment* is an important part of low energy buildings. New technology developments of luminaires and control strategies can minimize energy use and maximize IEQ by full exploitation of the daylight availability (responsiveness). The interplay between utilization of daylight, including shading, reflectance from surfaces and control of artificial lighting is rather complex. To add to the complexity, users have differing requirements to lighting and contrast levels. Further development by the providers of luminaires can be foreseen, and it is important that the other building services, and the BAS, are able to interact with these developments.

## 15 References

- [1] P. T. Meißner, *Die Heizung mit erwärmter Luft, erfunden, systematisch bearbeitet und als das wohlfeilste, bequemste, der Gesundheit zuträglichste, und zugleich der Feuersgefahr am meisten entfernende Mittel zur Erwärmung der Gebäude aller Art dargestellt u. praktisch nachgewiesen*. Vienna: Carl Gerold, 1823.
- [2] M. Haase, S. Holøs, Ø. Rønneseth, K. Thunshelle, L. Georges, and J. Thomsen, "Review of building services solution fitted for a low emission building stock in urban areas," 2019.
- [3] ZEB. (2017, 22.05). *ZEB Homepage*. Available: <https://www.zeb.no/index.php/en/>
- [4] M. Berge, "Indoor Climate Quality in High-Performance Dwellings. An Exploration of Measured, Perceived, and Desired Conditions," Doctoral thesis, Department of Architectural Design, History and Technology, NTNU, 2016.
- [5] J. Thomsen, L. Gullbrekken, S. Grynning, and J. Holme, "Evaluering av boliger med lavt energibehov (EBLE) – samlingsrapport," ed, 2017.
- [6] J. P. Burud, "KIWI Dalgård, et responsivt bygningskonsept," in *ZEN-konferansen 2018*, Oslo, 2018.
- [7] M. Mysen and P. G. Schild, "Behovsstyrt ventilasjon, DCV – forutsetninger og utforming," in "SINTEF Fag," Oslo2014, vol. 13.
- [8] M. Mysen and P. G. Schild, "Behovsstyrt ventilasjon, DCV – krav og overlevering," in "SINTEF Fag," 2013, vol. 11.
- [9] M. Mysen, P. G. Schild, and A. Cablé, "Demand-controlled ventilation – requirements and commissioning," in "SINTEF Research 24 " SINTEF Byggforsk,2014.
- [10] Ø. Rønneseth, "Personal Heating and Cooling Devices: Increasing Users' Thermal Satisfaction," in "ZEN report no. 4 - 2018," The Research Centre on Zero Emission Neighbourhoods in Smart Cities, FME ZEN2018, Available: <https://fmezen.no/wp-content/uploads/2018/06/ZEN-Report-no-4.pdf>.
- [11] N. Jones, "How to stop data centres from gobbling up the world's electricity," *Nature*, vol. 561, pp. 163-166, 2018.
- [12] L. C. M. Alfstad, "Analyse av termisk energiforsyning ved Otto Nielsens vei 12E," Master, Department of Energy and Process Engineering, NTNU, 2018.
- [13] M. Mysen, S. Berntsen, P. Nafstad, and P. G. Schild, "Occupancy density and benefits of demand-controlled ventilation in Norwegian primary schools," *Energy and Buildings*, vol. 37, no. 12, pp. 1234-1240, 2005/12/01/ 2005.
- [14] J. Halvarsson, "Occupancy Pattern in Office Buildings: Consequences for HVAC system design and operation," Doctoral thesis, Norwegian University of Science and Technology (NTNU), 2012.
- [15] P. M. Bluyssen and P. O. Fanger, "Addition of Olf's from Different Pollution Sources, determined by a Trained Panel," *Indoor Air*, Article vol. 1, no. 4, pp. 414-421, 1991.
- [16] P. Wargocki, P. O. Fanger, P. Krupicz, and A. Szczecinski, "Sensory pollution loads in six office buildings and a department store," (in English), *Energy and Buildings*, vol. 36, no. 10, pp. 995-1001, Oct 2004.
- [17] P. O. Fanger, "Introduction of the olf and the decipol units to quantify air pollution perceived by humans indoors and outdoors," *Energy and Buildings*, vol. 12, no. 1, pp. 1-6, 1988/04/24/ 1988.
- [18] O. Seppänen, N. Brelih, G. Goeders, and A. Litiu, "Existing buildings, building codes, ventilation standards and ventilation in Europe," in "HealthVent WP5 - The final report," 2012.
- [19] N. Holand, A. Yang, S. B. Holøs, K. Thunshelle, and M. Mysen, "Should we differentiate ventilation requirements for different user groups?," in *Cold Climate HVAC 2018 - Sustainable Buildings in Cold Climates*(Springer Proceedings in Energy: Springer, 2019, p. 10.
- [20] C. J. Weschler, "Chemistry in indoor environments: 20 years of research," *Indoor Air*, vol. 21, no. 3, pp. 205-218, 2011.
- [21] R. de Dear, "Revisiting an old hypothesis of human thermal perception: alliesthesia," *Building Research & Information*, vol. 39, no. 2, pp. 108-117, 2011/04/01 2011.
- [22] T. Parkinson and R. de Dear, "Thermal pleasure in built environments: physiology of alliesthesia," *Building Research & Information*, vol. 43, no. 3, pp. 288-301, 2015/05/04 2015.
- [23] X. Zhou, Q. Ouyang, G. Lin, and Y. Zhu, "Impact of dynamic airflow on human thermal response," (in eng), *Indoor Air*, vol. 16, no. 5, pp. 348-55, Oct 2006.
- [24] K. Thunshelle, "Oppvarming via tilluft. Veiledning og krav for næringsbygg med energiambisjoner," in "SINTEF Fag 38," SINTEF Byggforsk2016.
- [25] B. Venås, T. T. Harsem, and B. A. Børresen, "CFD simulation of an office heated by a ceiling mounted diffuser," presented at the 35th AIVC conference, 4th TightVent Conference, 2nd Ventilcool Conference "Ventilation and airtightness in transforming the building stock to high performance", Poznan, Poland, 24-25. September, 2014.

- [26] NVE, "Analyse av energibruk i yrkesbygg. Formålsdeling, trender og drivere," in "Rapport nr 24-2014," Norges vassdrags- og energidirektorat2016, Available: [http://publikasjoner.nve.no/rapport/2016/rapport2016\\_24.pdf](http://publikasjoner.nve.no/rapport/2016/rapport2016_24.pdf).
- [27] V. H. Madsen and H.-C. Gabrielsen, "Veikart for grønn handel 2050," Regjeringens ekspertutvalg for grønn konkurransekraft2016.
- [28] *Criteria for low energy and passive houses - Commercial buildings*, 3701, 2012.
- [29] A. Mæhlen, "Picture of Kiwi Dalgård," ed: Øystein Thommesen AS, 2017.
- [30] KIWI. (2017, 06.12). *I dag åpnet KIWIs nye miljøbutikk i Trondheim*. Available: <https://kiwi.no/Tema/samfunnsansvar/Miljo-og-barekraft/i-dag-apnet-kiwis-nye-miljobutikk-i-trondheim/>
- [31] Å. Lekang Sørensen, S. Jiang, B. Nybakk Torsæter, and S. Völler, "Smart EV Charging Systems for Zero Emission Neighbourhoods - A state-of-the-art study for Norway," in "ZEN Report No. 5," Research Centre on Zero Emission Neighbourhoods in Smart Cities2018.
- [32] M. G. Aaberg, "Analysis of the Thermal Energy System at Kiwi Dalgård," 2018.
- [33] J. Stene, M. Justo Alonso, Ø. Rønneseth, and L. Georges, "State-of-the-Art Analysis of Nearly Zero Energy Buildings," in "Country report IEA HPT Annex 49 Task 1 - Norway," 2018.
- [34] E. M. Sundlisæter *et al.*, "BOK 1 Funksjonsbeskrivelse - Totalentreprise bygg (E1) og totalentreprise teknikk (E2)," 2015.
- [35] Micro Matic, "Lær å forstå DALI lysstyring - Eliaden 2016," 2016, Available: <https://www.micromatic.no/siteassets/3-proffsenter/mm-skolen/presentasjoner/Dali-Eliaden-Presentasjon-Micro-Matic>.
- [36] J. Stene, "Refrigerants for the heat pump process," NTNU, TEP 4260 Heat Pumps for Heating and Cooling of Buildings2017.
- [37] H. T. Haukås, *Kompendium CO2 (R744) som kuldemedium*. Norsk Kjøleteknisk Forening, 2016.
- [38] Mattilsynet. (2018, 18.03). *Trygg mat i butikken*. Available: [http://www.matportalen.no/matsmitte\\_og\\_hygiene/tema/syk\\_av\\_maten/trygg\\_mat\\_i\\_butikken-1](http://www.matportalen.no/matsmitte_og_hygiene/tema/syk_av_maten/trygg_mat_i_butikken-1)
- [39] C. Olsen. (2018, 09.12). *Norske forskere bak iskald miljøteknologi*. Available: <https://gemini.no/2018/08/norske-forskere-bak-iskald-miljoteknologi/>
- [40] Emerson Climate Technologies, "Commercial CO2 Refrigeration Systems - Guide for Subcritical and Transcritical CO2 Applications," 744.com2014, Available: [http://www.r744.com/files/675\\_commercial\\_co2\\_guide.pdf](http://www.r744.com/files/675_commercial_co2_guide.pdf).
- [41] T. I. Bøhn, L.-H. Soreng, E. Holljen, F. Dehlin, and C. Grini, "Analyse av energibruk i forretningsbygg - Formålsdeling, trender og drivere," Norges vassdrags- og energidirektorat2014.
- [42] *SN/TS 3031:2016. Energy performance of buildings. Calculation of energy needs and energy supply*, 2017.
- [43] Sweco. (2016, 07.12). *FREMTIDEN ER NÅ: BERGENS FØRSTE BREEAM EXCELLENT OG NÆR NULLENERGIBYGG*. Available: <https://www.sweco.no/projects/sweco-bygget-i-bergen2/>
- [44] R. Bointner *et al.*, "Shopping malls features in EU-28 + Norway," in "Commonenergy," TU Vienna2014, Available: [http://commonenergyproject.eu/uploads/deliverable/file/1/WP2\\_D2.1\\_20141130\\_P05\\_Shopping\\_malls\\_features\\_in\\_EU-28\\_and\\_Norway\\_NP.pdf](http://commonenergyproject.eu/uploads/deliverable/file/1/WP2_D2.1_20141130_P05_Shopping_malls_features_in_EU-28_and_Norway_NP.pdf).
- [45] *Enovarapport*. Trondheim: Enova, 2003.
- [46] M. Stiller, *Quality lighting for high performance buildings*. Fairmont press, 2012.
- [47] J. Solt *et al.*, "Daylight in the Built Environment," vol. Changing perspectives on daylight: Science, technology, and culture (Supplement), ed, 2017, pp. 24-32.
- [48] A. Karmakar, S. Das, and A. Ghosh, "Energy Efficient Lighting by Using LED Vs. T5 Technology," *IOSR Journal of Electrical and Electronics Engineering (IOSR-JEEE)* vol. 11, no. 2 Ver 1 (Mar.-Apr. 2016), pp. 47-48, 2016.
- [49] NVE, "NVE legger opp til ny høring om nettleistruktur," ed: NVE - The Norwegian Water Resources and Energy Directorate, 2018.
- [50] W. Feist, J. Schnieders, V. Dorer, and A. Haas, "Re-inventing air heating: convenient and comfortable within the frame of the Passive house concept," *Energy and Buildings*, vol. 37, pp. 1186-1203, 2005.
- [51] M. Berge and H. M. Mathisen, "Perceived and measured indoor climate conditions in high-performance residential buildings," *Energy and Buildings*, vol. 127, pp. 1057-1073, 2016.
- [52] M. Berge, J. Thomsen, and H. M. Mathisen, "The need for temperature zoning in high-performance residential buildings," *Journal of Housing and the Built Environment*, pp. 1-20, 2016.
- [53] M. Berge, L. Georges, and H. M. Mathisen, "On the oversupply of heat to bedrooms during winter in highly insulated dwellings with heat recovery ventilation," *Building and Environment*, vol. 106, pp. 389-401, September 2016 2016.

- [54] J. Thomsen, L. Gullbrekken, S. Grynning, and J. Holme, "Evaluering av boliger med lavt energibehov (EBLE) - samlerapport," in "SINTEF Fag 43," SINTEF Byggforsk, SINTEF akademisk forlag 2017.
- [55] L. Georges, K. Wen, M. J. Alonso, M. Berge, and J. Thomsen, "Simplified Space-Heating Distribution using Radiators in Super-Insulated Apartment Buildings," presented at the SBE16 Tallinn and Helsinki Conference: Build Green and Renovate Deep, Tallinn and Helsinki, 5-7 October 2016.
- [56] L. Georges, F. Håheim, and M. J. Alonso, "Simplified Space-Heating Distribution using Radiators in Super-Insulated Terraced Houses," *Energy Procedia*, vol. 132, pp. 604-609, 2017/10/01/ 2017.
- [57] E. Selvnes, "Thermal zoning during winter in super-insulated residential buildings," Master thesis, Energy and Process Engineering Department, Norwegian University of Science and Technology (NTNU), Trondheim, 2017.
- [58] L. Georges, M. Berner, and H. M. Mathisen, "Air heating of passive houses in cold climate: investigation using detailed dynamic simulations," *Building and Environment*, vol. 74, pp. 1-12, 2014.
- [59] L. Georges, Ø. Skreiberg, and V. Novakovic, "On the proper integration of wood stoves in passive houses: investigation using detailed dynamic simulations," *Energy and Buildings*, vol. 59, pp. 203-213, 2013.
- [60] L. Georges, Ø. Skreiberg, and V. Novakovic, "On the proper integration of wood stoves in passive houses under cold climates," *Energy and Buildings*, vol. 72, pp. 87-95, 2014.
- [61] L. Georges and Ø. Skreiberg, "Simple modelling procedure for the indoor thermal environment of highly insulated buildings heated by wood stoves," *Journal of Building Performance Simulation*, vol. 9, no. 6, pp. 663-679, 2016.
- [62] L. Georges *et al.*, "Evaluation of Simplified Space-Heating Hydronic Distribution for Norwegian Passive Houses," in "ZEB Project report 39," 2017, Available: <http://hdl.handle.net/11250/2462461>.
- [63] *Moderate thermal environments - Determination of the PMV and PPD indices and specification of the conditions for thermal comfort*, I. S. Organisation 7730, 2005.
- [64] L. Georges, M. Thalfeldt, Ø. Skreiberg, and W. Fornari, "Validation of a transient zonal model to predict the detailed indoor thermal environment: Case of electric radiators and wood stoves," *Building and Environment*, vol. 149, pp. 169-181, 2019/02/01/ 2019.
- [65] L. Georges, K. Wen, M. J. Alonso, M. Berge, J. Thomsen, and R. Wang, "Simplified space-heating distribution using radiators in super-insulated apartment buildings," *Energy Procedia*, vol. 96, pp. 455-466, 2016.
- [66] TRNSYS. (2004, Jan 2005). *Trnsys16 user manual* [User manual]. Available: <http://sel.me.wisc.edu/trnsys/>
- [67] *Byggeteknisk forskrift (TEK10)*, D. f. byggkvalitet TEK 2010, 2010.
- [68] J. Thomsen, "EBLE – Evaluation of Buildings with a Low Energy Demand, 2015," J. Thomsen, Ed., ed: NSD – Norwegian Centre for Research Data, 2017.
- [69] M. Berge, "Indoor climate quality in high-performance dwellings : an exploration of measured, perceived and desired conditions," 2016:354, Norwegian University of Science and Technology, Faculty of Architecture and Fine Art, Department of Architectural Design, History and Technology, Trondheim, 2016.
- [70] K. Skeie, A. G. Lien, A. Svensson, and I. Andresen, "Kostnader for nye småhus til høyere energistandard," in "SINTEF byggforsk fag," SINTEF akademisk forlag, Oslo8253615257, 2016, vol. 37 Available: [https://www.sintefbok.no/book/index/1106/kostnader\\_for\\_nye\\_smaahus\\_til\\_hoeyere\\_energistandard](https://www.sintefbok.no/book/index/1106/kostnader_for_nye_smaahus_til_hoeyere_energistandard).
- [71] K. I. Edvardsen, *Trehus*, [10. utg.]. ed. (SINTEF byggforsk håndbok (trykt utg.)). Oslo: SINTEF akademisk forl., 2014.
- [72] M. Avantaggiato *et al.*, "Guidelines on how to approach the energy-efficient retrofitting of shopping centres," CommONEnergy, Vitenskapelig Kapittel/Artikkel/Konferanseartikkel 2017, Available: <http://hdl.handle.net/11250/2484215>.
- [73] R. Woods, S. E. Mellegård, R. D. Schlanbusch, K. Skeie, and M. Haase, "Shopping malls inefficiencies," CommONEnergy, Vitenskapelig Kapittel/Artikkel/Konferanseartikkel 2015, Available: [http://passivhus.dk/wp-content/uploads/7PHN\\_proceedings/010.pdf](http://passivhus.dk/wp-content/uploads/7PHN_proceedings/010.pdf).
- [74] P. Heiselberg, "Ventilative Cooling - State-of-the-art Review Executive Summary," in "Annex 62 - Ventilative Cooling," ENIVE EEIGISBN 2-930471-47-6, 2017, Available: <https://venticool.eu/wp-content/uploads/2012/09/SOTAR-summary.pdf>.
- [75] A. Belleri and M. Avantaggiato, "Ventilative Cooling," in "Commonenergy," EURAC2017, Available: [http://commonenergyproject.eu/uploads/deliverable/file/8/WP3\\_D3.3\\_20170109\\_P01\\_Ventilative\\_cooling.pdf](http://commonenergyproject.eu/uploads/deliverable/file/8/WP3_D3.3_20170109_P01_Ventilative_cooling.pdf).
- [76] P. O. Fanger, *Thermal comfort : analysis and applications in environmental engineering*. Malabar, Fla: Robert E. Krieger, 1982, p. 244 s.

- [77] A. Belleri, M. Haase, S. Papantoniou, and R. Lollini, "Delivery and performance of a ventilative cooling strategy: the demonstration case of a shopping centre in Trondheim, Norway," in *Ventilating healthy low-energy buildings: Air Infiltration and Ventilation Centre (AIVC)*, 2017, pp. 220-229.
- [78] A. M. Foster and G. L. Quarini, "Using advanced modelling techniques to reduce the cold spillage from retail display cabinets into supermarket stores to maintain customer comfort," *Proceedings of the Institution of Mechanical Engineers, Part E: Journal of Process Mechanical Engineering*, vol. 215, no. 1, pp. 29-38, 2001.
- [79] B. A. Fricke and B. R. Becker, "Doored display cases: they save energy, don't lose sales.(Report)," *ASHRAE Journal*, vol. 52, no. 9, p. 18, 2010.
- [80] Federico Visconti, Maurizio Orlandi, and O. Saro, "Thermal zone optimization," in "Commonenergy," EPTA2015, Available: [http://commonenergyproject.eu/uploads/deliverable/file/7/WP3\\_D3.2\\_20151126\\_P12\\_P17\\_Thermal\\_zone\\_optimization\\_CO.pdf](http://commonenergyproject.eu/uploads/deliverable/file/7/WP3_D3.2_20151126_P12_P17_Thermal_zone_optimization_CO.pdf).
- [81] M. Rozanska *et al.*, "Concept of modular multifunctional facade," in "Commonenergy," ACCIONA2017, Available: [http://commonenergyproject.eu/uploads/deliverable/file/9/WP3\\_D3.4\\_20171124\\_P03\\_Concept\\_of\\_modular\\_multifunctional\\_facade.pdf](http://commonenergyproject.eu/uploads/deliverable/file/9/WP3_D3.4_20171124_P03_Concept_of_modular_multifunctional_facade.pdf).
- [82] M. Bukat, T. Niewczas, Ł. Koziół, J. Łazowski, and A. de Ferrari, "Green integration," in "Commonenergy," CIM2015, Available: [http://commonenergyproject.eu/uploads/deliverable/file/10/WP3\\_D3.5\\_20161129\\_Green\\_integration.pdf](http://commonenergyproject.eu/uploads/deliverable/file/10/WP3_D3.5_20161129_Green_integration.pdf).
- [83] B. Froehlich and A. Ampenberger, "Prototypes of combined daylight system," in "Commonenergy," BLL2017, Available: [http://commonenergyproject.eu/uploads/deliverable/file/13/WP3\\_D3.8\\_20170131\\_P09\\_Prototype\\_of\\_combined\\_daylight\\_system.pdf](http://commonenergyproject.eu/uploads/deliverable/file/13/WP3_D3.8_20170131_P09_Prototype_of_combined_daylight_system.pdf).
- [84] A. Ampenberger, "Daylight strategies," in "Commonenergy," BLL2017, Available: [http://commonenergyproject.eu/uploads/deliverable/file/12/WP3\\_D3.7\\_20170131\\_P09\\_Daylight\\_strategies.pdf](http://commonenergyproject.eu/uploads/deliverable/file/12/WP3_D3.7_20170131_P09_Daylight_strategies.pdf).
- [85] S. Staggl, K. Reiter, and A. Ampenberger, "Visual emotional and energy effects of a new lighting concept," in "Commonenergy," BLL2017, Available: [http://commonenergyproject.eu/uploads/deliverable/file/20/WP4\\_D4.9\\_20170116\\_P09\\_Visual\\_emotional\\_and\\_energy\\_effects\\_of\\_a\\_new\\_lighting\\_concept.pdf](http://commonenergyproject.eu/uploads/deliverable/file/20/WP4_D4.9_20170116_P09_Visual_emotional_and_energy_effects_of_a_new_lighting_concept.pdf).
- [86] J. Antolin *et al.*, "Energy savings results," CommONEnergy, Vitenskapelig Kapittel/Artikkel/Konferanseartikkel 2017, Available: [http://commonenergyproject.eu/uploads/deliverable/file/35/WP6\\_D6.4\\_20171010\\_P04\\_Energy\\_savings\\_results.pdf](http://commonenergyproject.eu/uploads/deliverable/file/35/WP6_D6.4_20171010_P04_Energy_savings_results.pdf).
- [87] M. Haase and A. Ampenberger, "Implications of Increasing Daylighting in Deep Energy Retrofitting in Norwegian Shopping Centres," in *Building Simulation Applications. BSA 2017*(Building Simulation Applications: International Building Performance Simulation Association (IBPSA), 2017.
- [88] M. Haase and A. Ampenberger, "The role of lighting in deep energy retrofitting in European shopping malls," in *Proceedings of the eceee Summer Study. Consumption, efficiency & limits. 29 May - 3 June 2017 Toulon/Hyeres, France*(Eceee ... summer study proceedings: European Council for an Energy Efficient Economy (ECEEE), 2017, pp. 1013-1018.
- [89] N. Daldosso, E. Gentile, S. Mangili, and S. Papantoniou, "ITC platform," in "Commonenergy," Schneider Electric2017, Available: [http://commonenergyproject.eu/uploads/deliverable/file/17/WP4\\_D4.4\\_20170131\\_P06 ICT\\_platform\\_systems.pdf](http://commonenergyproject.eu/uploads/deliverable/file/17/WP4_D4.4_20170131_P06 ICT_platform_systems.pdf).
- [90] M. Haase, R. Woods, and K. S. Skeie, "Capacities in shopping malls to supply grid services," in *Proceedings of the 20th Annual International Sustainable Development Research Conference (ISDRC 2014)*: Norwegian University of Science and Technology, Department of Product Design, 2014.
- [91] M. Haase, "Renewable energy supply potential of shopping centres," presented at the International Conference on Energy, Environment and Economics -ICEEE2016, Edinburgh, 2016-08-16 - 2016-08-18, 2016. Konferanse.
- [92] M. Haase, J. Antolin, and A. Belleri, "Interactions of retrofitted shopping centres with local energy grids," in *9th International Conference Improving Energy Efficiency in Commercial Buildings and Smart Communities. IEECB&SC'16*(EUR: European Union, 2016, pp. 475-486.
- [93] M. Haase *et al.*, "Interactions of shopping centres with local energy grids," (in Engelsk), *NewDist - NEWSLET TER SEMESTRALE DEL DIPARTIMENTO INTERATENEO DI SCIENZE, PROGET TO E*



- POLITICHE DEL TERRITORIO POLITECNICO E UNIVERSITA' DI TORINO*, Vitenskapelig Kapittel/Artikkel/Konferanseartikkel pp. 144-153, 2016.
- [94] J. Antolin *et al.*, "Interaction with local energy grid," CommONEnergy, Vitenskapelig Kapittel/Artikkel/Konferanseartikkel 2015, Available: [http://commonenergyproject.eu/uploads/deliverable/file/4/WP2\\_D2.4\\_20150430\\_P04\\_Interaction\\_with\\_local\\_energy\\_grid\\_NotPrintable.pdf](http://commonenergyproject.eu/uploads/deliverable/file/4/WP2_D2.4_20150430_P04_Interaction_with_local_energy_grid_NotPrintable.pdf).
- [95] M. Haase, K. S. Skeie, A. Belleri, and C. Dipasquale, "Modelling of complex shopping mall in Norway," in *Proceedings of Building Simulation 2015, The 14th International Conference of IBPSA: International Building Performance Simulation Association (IBPSA)*, 2015, pp. 2264-2270.
- [96] M. V. C. Vázquez *et al.*, "Systemic solution-sets," in "Commonenergy," SINTEFD5.1, 2017, Available: <http://hdl.handle.net/11250/2484217>  
<http://www.wiley.com/Corporate/Website/Objects/Products/0,9049,566289,00.html>.
- [97] C. Dipasquale, A. Belleri, and R. Lollini, "Integrative Modelling Environment " in "Commonenergy," EURAC2016, Available: [http://commonenergyproject.eu/uploads/deliverable/file/15/WP4\\_D4\\_1\\_20161124\\_P01\\_Integrative\\_Modelling\\_Environment\\_FINAL\\_v9.pdf](http://commonenergyproject.eu/uploads/deliverable/file/15/WP4_D4_1_20161124_P01_Integrative_Modelling_Environment_FINAL_v9.pdf).
- [98] M. Haase and K. S. Skeie, "Energy efficient commercial building refurbishment in Nordic climate," in *Proceedings of CLIMA 2013: Society of Environmental Engineering (STP)*, REHVA member association, 2013, p. 6882.
- [99] M. Haase and K. S. Skeie, "Development of protocol for sub-metering for simulation models of shopping centres," in *CISBAT 2015 - FUTURE BUILDINGS & DISTRICTS SUSTAINABILITY FROM NANO TO URBAN SCALE PROCEEDINGS VOL. II: Ecole Polytechnique Fédérale de Lausanne (EPFL)*, 2015, pp. 809-814.
- [100] M. Haase, K. S. Skeie, and R. Woods, "The key drivers for energy retrofitting of European shopping centres," (in Engelsk), *Energy Procedia*, Vitenskapelig Kapittel/Artikkel/Konferanseartikkel vol. 78, pp. 2298-2303, 2015.

## 16 Appendices

### Appendix A: Demand control in schools and offices: BestVent

#### Introduction

The amount of ventilation necessary to maintain good IAQ (indoor air quality) in a room depends on the strength of the pollution from interior surfaces, furniture, and occupants. These pollution sources are either stationary or variable. The variable sources are mainly users and user-related activities. The purpose of demand-controlled ventilation (DCV) is to continuously adjust the ventilation rate to the current demand. The potential benefits and practical implications of DCV has been studied in a range of SINTEF projects. Important results have been published as practice-oriented reports and guidelines [7, 8].

DCV achieves the greatest energy savings in buildings with highly variable occupancy during the operating hours as the ventilation rates are significantly reduced for extended periods, because the rooms are empty or with fewer people than design occupancy [13, 14]. Many office buildings and virtually all school buildings possess this usage pattern, and DCV has thus emerged as a dominant ventilation strategy for such buildings in Norway.

The ventilation airflow rate in modern DCV systems is controlled between pre-set minimum ( $V_{\min}$ ) and maximum ( $V_{\max}$ ) limit values, based on the signal from one or more room sensors (see Figure 8). The values for  $V_{\min}$  and  $V_{\max}$  can be set to account for changes in, for example, pollutant load from materials, room size, or the maximum likely number of occupants [9].

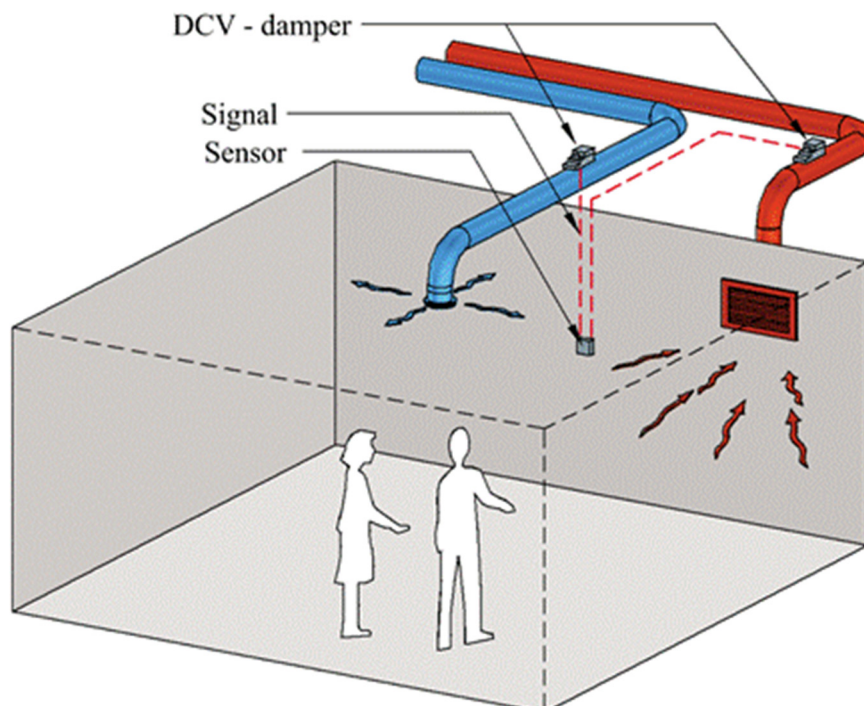

**Figure 8** Illustration of a room with DCV. A sensor picks up the pollution level and signals DCV-dampers about a corresponding ventilation volume to maintain IAQ (Illustration: SINTEF).

## Design criteria

### Choice of maximum ventilation airflow rate, $V_{\max}$

Maximum ventilation airflow rate,  $V_{\max}$ , should be selected to maintain acceptable IAQ considering the emission load from materials, people and activity at design conditions as well as maintain desired indoor temperatures. In many buildings, the design cooling load will determine  $V_{\max}$ , and actual cooling demand determine actual ventilation rate in warmer periods of the year.

According to the building code, ventilation rates should add ventilation demands due to emissions from materials, people and processes. The scientific basis for this addition is somewhat vague, but probably builds mainly on the work of Ole Fanger on perceived air quality as a measure of pollution load [15-17].

### Choice of minimum ventilation airflow rate, $V_{\min}$

The choice of minimum ventilation airflow rate,  $V_{\min}$ , has an obvious impact on energy use, but there are few studies on the impact on IAQ. Thus, there are no scientifically-based optimal guidelines for  $V_{\min}$ . The present rationale for choosing  $V_{\min}$  is to maintain a constant IAQ in accordance with Fanger's olf-based<sup>1</sup> "addition principle" [17]. This implies that  $V_{\min}$  is set to achieve an acceptable olfactory concentration accounting for the total pollutant load from materials and occupants in the room. For unoccupied rooms, this minimum ventilation demand varies typically from 0.7 to over 2 (l/s)/m<sup>2</sup><sub>floor</sub> in Norway.  $V_{\min}$  is often set to the upper end of this range due to risk of high emitting furniture, or technical limitations in the equipment such as flow-measurement. However, we should depart from this practice, and instead acknowledge that unoccupied rooms do not need to be intensively ventilated primarily for olfactory comfort. The remaining question is whether reducing  $V_{\min}$  has any negative impact on perceived air quality (PAQ), indoor-air related symptoms, health, or human performance when an occupant enters the empty room.

We found that increasing  $V_{\min}$  had a significant positive impact on PAQ in rooms with extra pollution sources. This effect was not present in the low-emitting rooms with temperatures at  $21.5 \pm 1^\circ\text{C}$ . We could not see that different airflow rates had an impact on PAQ, performance or well-being in the dedicated *test room* during the first 20 minutes of occupation. This indicates that  $V_{\min}$  above 1 (l/s)/m<sup>2</sup> has limited impact on IAQ in real low-emitting rooms. Our preliminary recommendation is to restrict  $V_{\min}$  to 1 (l/s)/m<sup>2</sup> in rooms designed to be low-emitting. Additional ventilation due to uncertain pollution load from materials or equipment should be included in the choice of  $V_{\max}$ . This preliminary recommendation is based on the prerequisite that a DCV-system has easily adjustable  $V_{\min}$  and  $V_{\max}$ . This means that  $V_{\min}$  can be easily adjusted in the case of rooms not successfully fitted as a low-emitting room if the pollution load is changed by different use of the room or changes in room size.

### Controlling airflow between minimum and maximum ventilation airflow rates, $V_{\min}$ and $V_{\max}$

Previous studies have resulted in a wide range of recommended ventilation rates per person or per floor area, and as shown by the HealthVent review report [18], are mainly based on studies with constant ventilation rates, and with few studies separating ventilation requirements due to different sources. Studies of different age and from different countries may vary considerably due to e.g. emission from

---

<sup>1</sup> olf is a unit used to measure the strength of a pollution source.

materials and secondary or tertiary tobacco smoke. Recommendations built on such studies are not necessarily suitable for DCV-system dynamics.

The most common approaches to control the ventilation rate is adjustments according to CO<sub>2</sub> in room air, or through detection of presence. As CO<sub>2</sub> is mainly an indicator of human metabolism, its suitability as control signal depends on the assumption that emission of bio-effluents correlates with CO<sub>2</sub>-emissions. This assumption has been contested [19]. Some suppliers rely on signals from VOC-sensors (VOC = volatile organic compound) instead of CO<sub>2</sub>-sensors, but it is presently unclear whether this correlate any better with air quality.

Perceived air quality is heavily influenced by enthalpy, as the cooling effect of cool and dry air reduces the discomfort of odours and irritants. Thus, there is scientific support for changing CO<sub>2</sub> setpoint according to indoor temperatures.

The growing field of indoor chemistry [20] has proved that chemical reactions on surfaces affects the composition of indoor air significantly, and that reactive compounds in the outdoor air (particularly ozone and nitrogen oxides) is an important contributor to such reactions. It is possible that indoor chemical reactions should be taken into account when designing DCV control systems for optimal air quality and energy demand.

### **Conclusions and need for further work**

Demand-controlled ventilation is an important technology for reducing energy demand in many non-residential buildings, and the potential energy savings are increased where low-emitting materials, furniture and fixtures are used. Furthermore, it could be applied to increase power flexibility.

In order to unleash the potential energy and power saving effects while improving – or at least not diminishing – indoor air quality, there is a need for a better understanding of the dynamic processes of the indoor air, to develop better models for predicting health, productivity and comfort effects, and control systems that can take this knowledge into account. Such control systems should preferably make use of both a larger range of sensor signals as well as predictions for e.g. outdoor air quality and building usage. With a better understanding of the processes, the potential and limitations of shifting power loads by control of ventilation systems will become clearer.

Our finding that ventilation requirements may vary between age groups within a primary school stresses the need for a better understanding of how different user groups (age, activity level, health status, etc.) vary in their ventilation requirements. This is most likely even more true with other user groups (e.g. in nursery homes) or more varied activities. A more complete understanding of what constitutes good air quality, and how it best can be measured is desirable and achievable.

## Appendix B: Cooling by higher air speed: Svalvent

In today's well-insulated buildings, the heating demand has been significantly reduced, and a larger share of the energy is used for cooling purposes. At the same time not all users are satisfied with the indoor temperature during the summer. The project SvalVent<sup>2</sup> seeks to find more energy efficient cooling methods, while also improving thermal comfort. If successful, cooling to a general higher temperature can save both energy as well as installation costs, allowing individual demand control of high temperature cooling.

Draft limits given by NS-EN ISO 7730 stating that high air velocities should be avoided as the occupants may experience draft, is challenged. This is based on earlier research, often referred to as the Fanger theory. Persons being in neutral state, not feeling cold nor warm, and thereby desire no or low air velocity. New research is considering the psychophysiological phenomenon, alliesthesia [21, 22] – thermal pleasure, accompanied by studies of natural wind [23]. The theory is that by feeling slightly warm, higher tolerance of air velocities is accepted and resulting in even more satisfied users than by no draft at neutral state. Further, if the air flow can copy characteristics given by natural wind, this seem to be preferable to mechanical forced airflow. Hence, a deviation from the common requirements could be suggested if the air velocity is under personal control. During summer conditions with indoor operative temperatures above 25 °C, increased air velocity can then be used to compensate for increased air temperatures to achieve thermal comfort. The actual solution needs to be documented by acceptable air temperature, air velocity and turbulence intensity.

The main goal of the ongoing research project SvalVent is to develop a user-controlled cooling concept combining experiences from use of demand-controlled ventilation and active valves for supply air, which alone covers the cooling demand in open plan offices, and a new product enabling individual demand-control. This allows for energy savings by higher cooling temperature.

To develop a new product and concept, new knowledge about the physiological, physical and medical basis is vital. Experiments for summer conditions have therefore been conducted at SINTEF Community's laboratories, as shown in Figure 9. Occupants of different age and gender are placed in a test room corresponding to an open plan office with four working stations. Varying room temperatures, supply air temperatures and air speeds have been studied. The test persons are exposed to varying conditions throughout the day. Every time one condition is changed, the occupants answers a simple questionnaire to report on their thermal comfort. In addition, the occupants are equipped with medical equipment, such as sensors for skin temperature and sweat detection, to document how they react to their environment. Physical parameters like temperature conditions, airflow rate and velocity are documented throughout the experiments. The results from the lab experiments in 2018 were promising. The prototype is further developed and integrated to existing system for full scale field tests at Entra during summer 2019.

---

<sup>2</sup> SvalVent - Cool and comfortable demand-controlled ventilation for individual cooling in non-residential buildings, <https://www.sintef.no/projectweb/svalvent/>.



**Figure 9** Pictures from the lab experiment in March 2018. Photos: SINTEF; Kari Thunshelle.

## Appendix C: Ventilation-based heating: ForKlima

### Introduction

The research project ForKlima was launched to study simplified solution for providing thermal comfort in the heating season in office buildings with very low heating demand. The background for ForKlima is that stricter energy requirements lead to new buildings with very low heating demand, even during cold days, and the development of solutions that are almost fully conditioned with ventilation, like Miljøhuset GK. The project involved laboratory measurements, field measurements and CFD-simulations. ForKlima documents that simplification based on full climatization with ventilation can work, but it presupposes a well-insulated building envelope. The solution is connected to the products tested in Miljøhuset GK with a possibility for extra added power from electric heating elements.

**Ventilation-based heating, as used in the 1980'ies, is related to negative user satisfaction. Typical problems were short-circuiting and the feeling of too warm air in head-height. As shown in**

Table 3, buildings before 1987 typically have a heating demand of ca 80 kWh/(m<sup>2</sup>·year), while new highly-insulated buildings typically have a heating demand of 15 kWh/(m<sup>2</sup>·year). Necessary heating demand per square meter is drastically reduced, and thereby also significantly lower overtemperature for the supply air is needed, even for cold days. The heating season for new buildings is changed from a large part of the year to shorter periods. This gives new possibilities for ventilation-based low-temperature heating.

**Table 3 Changed technical specifications for buildings, typical figures.**

	Before 1987	Passive house
Insulation thickness	10-15 cm	30 cm
U-value wall	0,36 W/(m <sup>2</sup> ·K)	0,12 W/(m <sup>2</sup> ·K)
U-value window	1,6 W/(m <sup>2</sup> ·K)	0,8 W/(m <sup>2</sup> ·K)
Air leakage numbers	n <sub>50</sub> = 1,5 ACH	n <sub>50</sub> = 0,6 ACH
Space heating demand	ca 80 kWh/(m <sup>2</sup> ·year)	15 kWh/(m <sup>2</sup> ·year)

This raised the following research questions:

- Can short periods with over-tempered supply air be acceptable for the users?
- Is there a risk for short-circuiting?
- Is there a draft risk for this kind of solution when the heat source by the window is removed?
- Can ventilation-based heating be used solely with no extra heating, even on cold days?
- What overtemperatures can be accepted?

The following methods were used:

- Cross-over intervention studies for documenting user satisfaction with over-tempered supply air.
- Field lab in typical office for studies of temperature, draft risk and ventilation effectiveness on cold winter days.
- Lab experiments for studying of ventilation effectiveness.
- CFD simulations on draft risk and ventilation effectiveness for design outdoor temperature.

### Design criteria

Recommendations and requirements for ventilation-based heating in commercial buildings can be found in a separate report [24], but are briefly summarized below.

## Ventilation effectiveness

Ventilation effectiveness is studied both by lab experiments and CFD simulations

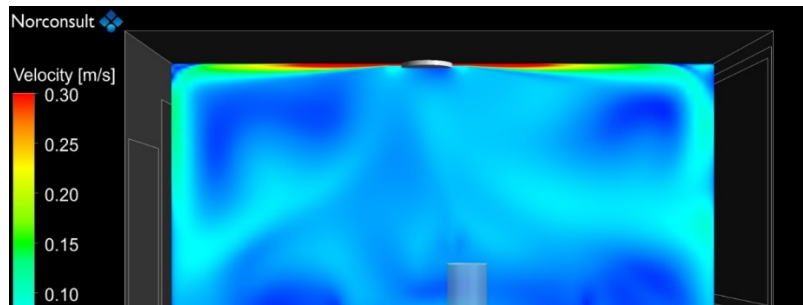
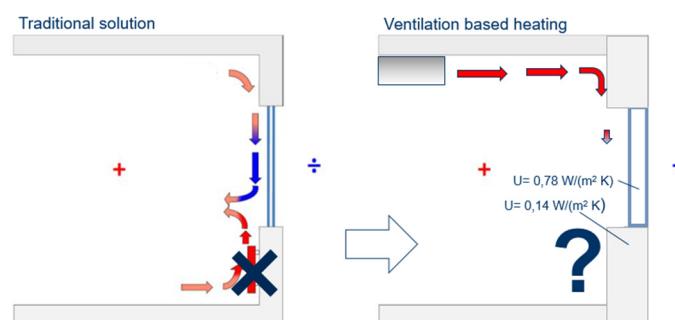

**Figure 10** An active supply valve maintaining the velocity at different airflow rates is important for the ventilation efficiency when heating through supply air [25].

## Draft risk and thermal comfort

Good thermal comfort can be assessed according to NS-EN ISO 7730. Conditions for thermal comfort are described in more details in the Norwegian Building Design Guideline 421.501. In short, good thermal comfort is achieved with low radiation asymmetry, low stratification, and low air speed.

Air speed caused by downdraft as well as radiation asymmetry should be avoided. A traditional office has a significant heat loss and needs heating. The window field will normally be a cold surface in the building envelope and contribute significantly to cold radiation and downdraft. By placing a heat source under the window, local heating is achieved while at the same time downdraft from the window is reduced. The heat source has traditionally served two functions which together create a good thermal indoor climate; heating and preventing draft/cold radiation.

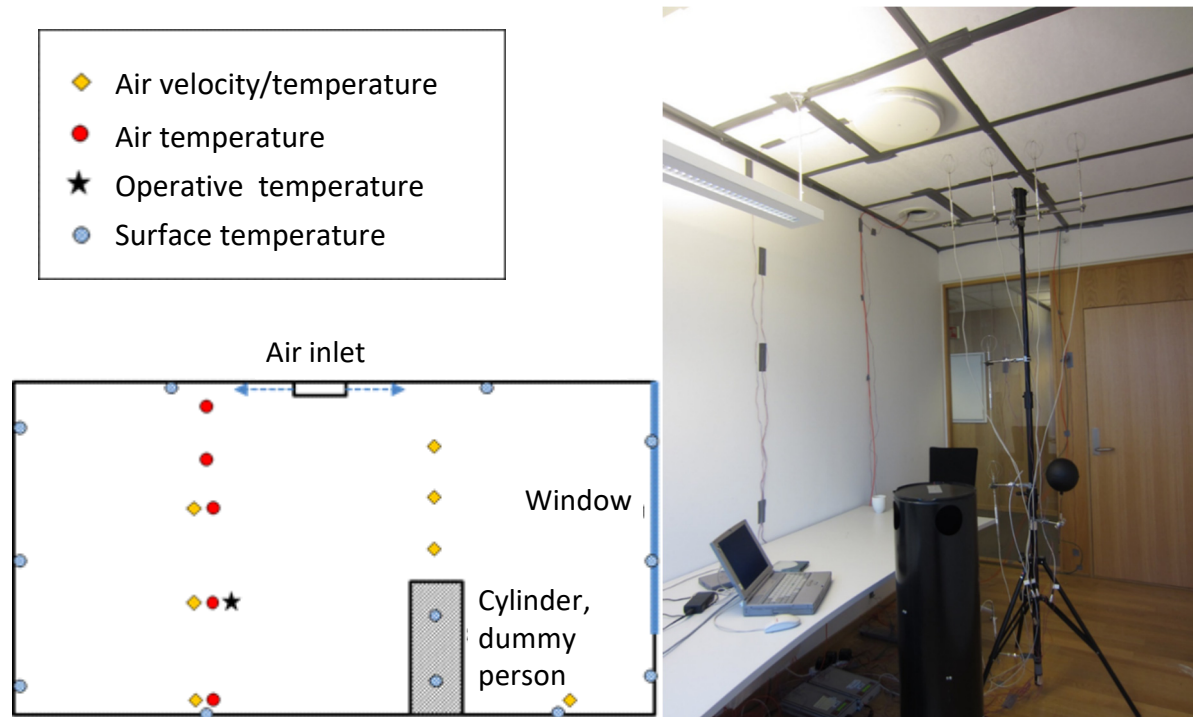

**Figure 11** Transition from the traditional solution for offices to heating via supply air.

In a well-insulated building, the heating demand is very low, and a change from U-value 1.6 to 0.8  $W/(m^2 \cdot K)$  can result in a more than 4 °C increased surface temperature on cold winter days (see Forklima rapport). The cold radiation from the window decreases and the increased surface temperature results in reduced airspeed and downdraft by the window.



Field lab measurements in single office equipped with instruments for thermal and air speed measurements can document some of the characteristics by ventilation-based heating with active inlet valve. Results were later used as calibration for CFD-calculation on design temperature in Oslo.



**Figure 12** Field lab set up.

Both measurements and simulations show satisfactory conditions within the limits of the standard. The CFD simulations show low air speeds close to window even on the coldest winter periods. It is here to remark that high windows need to be studied more carefully, as the downdraft will increase in speed by height. The studied situation is construction with jamb wall and window height ca 1.80m in Oslo climate. Lower design temperature or higher U-value will also increase risks of draft and radiation asymmetry and need further calculations. Also, physical measurements showed low air speeds close to window surface. However, desks should not be placed directly towards window surface.

Stratification is caused by hot air rising to the ceiling, and limited variation between leg and head is necessary for thermal comfort. Mixed ventilation mode is supplied with under tempered air by the ceiling, whereas the high speed and under-tempered air contribute to the mixing. Introducing isothermal or slightly over-tempered air, the resulting stratification in the room is studied for the given inlet valve. Different heating strategies were studied: low ventilation rate and high over temperature, high ventilation rate and low over temperature, with or without internal load (heating source). As shown in figure 3, all strategies resulted in even distributions, with small variation between leg and head, clearly fulfilling standard demands. The studied inlet valve provides good results for varying heat strategies.

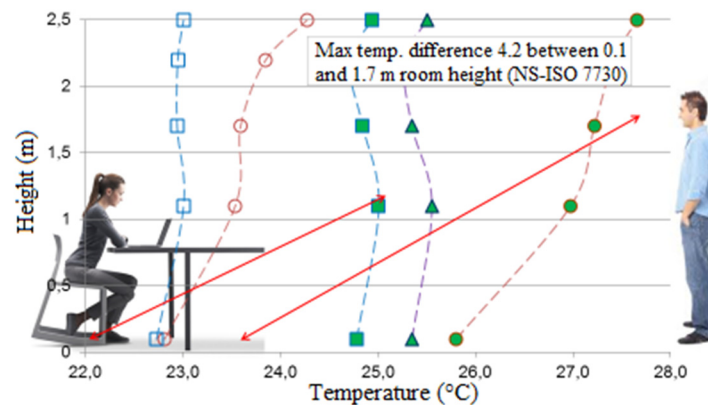

Figure 13 Temperature stratification in the cellular office [24].

### A stand alone solution? Suitability

The use of ventilation-based heating prerequisites a highly insulated building envelope.

ForKlima reports the following rule of thumb for simplification:

The solution is reliable when:

$$P(tr + inf) < \text{Minimum internal heat gains for rooms in use}$$

The solution may be considered when:

$$P(tr + inf) < \text{minimum internal heat gains} + \left(\frac{\dot{V}}{3}\right) \times 2^\circ\text{C overtemperature}$$

where:

$P(tr+inf)$  = Heating demand due to transmission- and infiltration heat loss ( $\text{W}/\text{m}^2$ )

Internal heat gains = Heat gain from persons, equipment and lighting

$\dot{V}$  = Airflow rate ( $\text{m}^3/(\text{h}\cdot\text{m}^2)$ )

## Appendix D: Energy efficient grocery store: Kiwi Dalgård

Grocery stores are among the buildings with the highest specific energy demand and could have an energy use of as much as 500-800 kWh/(m<sup>2</sup>·yr) [26]. The grocery business thus has a large potential for improved energy efficiency through utilizing of low-emission building services solutions. Refrigerators and freezers for groceries account for close to half of the total energy use in the stores. By implementing heat recovery from this process cooling, the surplus energy can be utilized for heating purposes, either in the same building or neighbouring buildings. Such smart use of energy is essential for creating zero emission neighbourhoods.

*Veikart for grønn handel 2050* (Roadmap for green trade 2050) [27] suggests several measures that the trade business can implement themselves to contribute to make Norway climate neutral within 2050. Some of the suggestions are to evaluate solutions for distribution, warehouses, and stores regarding

climate and environment, carry out energy efficiency measures with a target of 100 % renewable energy and set environmental requirements for transport contractors.

This chapter presents low-emission building services solutions used at KIWI Dalgård in Trondheim. KIWI Dalgård (Figure 14) was finished in 2017 and was the fourth "green" KIWI store with an extra focus on the environment. It has a floor area of 1250 m<sup>2</sup>, it is built according to the Norwegian passive house standard (NS 3701) and will during operation produce more energy than it uses through the application of solar cells (PV), a ground-source heat pump and heat recovery from the refrigeration system. Surplus thermal energy is delivered to 60 apartments in the neighbouring buildings [28].



**Figure 14 KIWI Dalgård in Trondheim. Parts of the façade is covered with building integrated solar cells [29].**

KIWI and NorgesGruppen have high ambitions of reducing their greenhouse gas emissions and are willing to test innovative solutions to succeed with their aim of becoming carbon neutral. Positive experiences from the first "green" store led to the decision that all new KIWI-stores should have a higher environmental standard. This involves solutions such as an improved building envelope insulation, using carbon dioxide CO<sub>2</sub> (R744) as the working fluid for the refrigeration systems (freezing and cooling), LED-lighting and simple and effective measures such as using doors on all refrigerators and freezer cabinets.

A holistic approach is applied to make KIWI Dalgård as environmentally friendly as possible. Wood is used to a large extent in walls and facades, while other measures are three-layer windows, low-carbon concrete, aerogel for increased daylight into the store and Noxite roofing which neutralises NO<sub>x</sub>-particles from the air. In addition, ASKO's trucks that deliver groceries to KIWI Dalgård are using electricity or hydrogen produced by their own wind farms and solar cells. ASKO has an ambition of being self-supplied with clean energy in 2020 [30]. Outside the store there are charging stations for electric vehicles and bikes. For more information about the charging systems, see ZEN report No. 5, "Smart EV Charging Systems for Zero Emission Neighbourhoods – A state-of-the-art study for Norway" [31].

The thermal energy system for KIWI Dalgård was during 2018 analysed through a project assignment for a master student at NTNU (Marie Garen Aaberg). Findings from the analysis [32] relevant for this

report are presented here, while the full analysis will be included in a report summarizing results from field measurements in IEA Heat Pumping Technologies Annex 49 “Design and Integration of Heat Pumps for Nearly Zero Energy Buildings”. The annex has already published another open access report called “State-of-the-Art Analysis of Nearly Zero Energy Buildings” [33]. This report provides an overview of applied HVAC technologies in energy-efficient buildings in Norway, such as the pilot projects of FME ZEB and FutureBuilt. It also includes the market state of heat pumps in Norway and design criteria to achieve optimal heat pump systems. Heat pumps is an essential technology for reducing the primary energy use for heating and cooling of buildings, as well as to utilize surplus energy sources on a neighbourhood scale <sup>3</sup>.

### Description of technical solutions used at KIWI Dalgård

Figure 15 shows a principle sketch of the thermal energy system at KIWI Dalgård. The numbering in the sketch corresponds to the description of the main components in Table 4, which also shows design supply and return temperatures for the heating system.

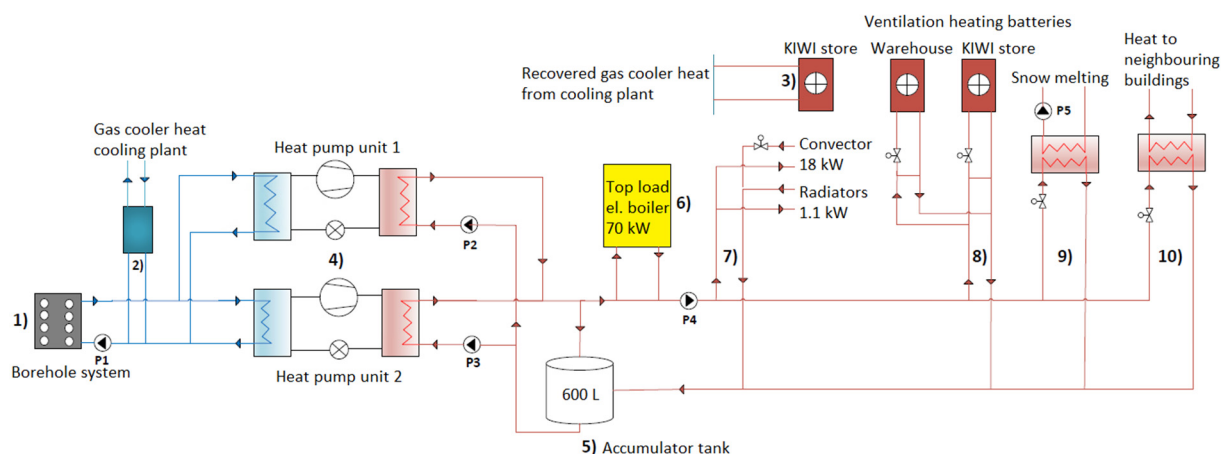

Figure 15 Principle sketch of the thermal energy system [32].

Table 4 Thermal energy system at KIWI Dalgård summarized [32].

Nr	Main components	Description	Supply/return temperatures
1)	Borehole system	<ul style="list-style-type: none"> <li>Eight boreholes with depth 270 m</li> <li>Ethanol (HXi-35)</li> </ul>	1/4 °C
2)	Refrigeration plant	CO <sub>2</sub> as refrigerant	20/45 °C
3)	Recovered gas cooler heat from the refrigeration plant	Covers the heating demand for ventilation air heating in the store for large parts of the year	20/45 °C
4)	Ground-source heat pump system	<ul style="list-style-type: none"> <li>Carrier AquaSnap, R410A</li> <li>Supplies heat to radiators in KIWI and to neighbouring buildings</li> <li>Capacity 2 x 39.7 kW (4/50 °C)</li> </ul>	4/50 °C
5)	Accumulator tank	<ul style="list-style-type: none"> <li>Capacity 600 L</li> </ul>	N/A

<sup>3</sup> For further information the report can be downloaded from here:

<https://www.sintefbok.no/book/index/1188/state-of-the-art-analysis-of-nearly-zero-energy-buildings-country-report-iea-hpt-annex-49-task-1-norway>

Nr	Main components	Description	Supply/return temperatures
		<ul style="list-style-type: none"> <li>Ensures constant flow on the condenser side</li> <li>Reduces start/stop for heat pump compressors</li> </ul>	
6)	Electric boiler	Peak load, 70 kW, designed to never be used	N/A
7)	Radiators and convector	Heating storage and staff area	50/30 °C
8)	Ventilation	Three heater batteries for the AHU	50/30 °C
9)	Snow melting	Snow melting outside the store during wintertime, capacity 70 kW	35/20 °C
10)	Heat to neighbouring buildings	Delivered heat is estimated to 350-400 000 kWh/year.	45/25 °C after heat exchanger

The ground-source system consists of eight vertical boreholes situated around the building, each with a depth of 270 m and 14 m between the boreholes. The potential for annual heat extraction from the ground is estimated to be 600 000 kWh. Two heat pump units are connected to the borehole system, each with a capacity of 39.7 kW (at entering brine temperature 4 °C and leaving water temperature 50 °C). One of the heat pump units is controlled on/off, while the other has variable speed drive (VSD) control. The condensers are connected in parallel after a 600 L accumulation tank. An electric boiler (capacity 70 kW) is installed as top load but is not intended to be used.

The heating setpoint of the store is 21 °C. Preheated and temperate ventilation air is sufficient as supplied heat to the store areas, due to internal loads from refrigerators, freezers, and lighting. The ventilation is VAV controlled, and so the airflow rate is adapted to reach the temperature setpoint. The staff area in the building is heated by a hydronic radiator system (1.1 kW), while the storage area is heated by a hydronic convactor (18 kW) mounted in the ceiling. The design supply and return temperature for the heating battery in the air handling unit and radiator/convactor system is 50/30 °C. Recovered heat from the refrigeration system is primarily used for heating of ventilation air, while excess heat is rejected to the borehole systems for thermal storage or "charging" of the system. The recovered heat covers the heating demand for ventilation through large periods of the year, and when it is not sufficient, hydronic heater batteries connected to the heat pump system covers the remaining temperature lift for the supply air.

Thermal energy is exported from the ground-source heat pumps to the neighbouring buildings and used both for space heating and preheating of domestic hot water (DHW). Exported heat was estimated to be 350 000-400 000 kWh/year, and the power for space heating and DHW heating 50 kW and 17 kW respectively. Figure 16 shows a principle sketch for the thermal energy system at the neighbouring apartment blocks. Water at 50 °C from KIWI is delivered to a heat exchanger whereas an electric boiler reheats the water to 60 °C for the radiators. The cooled water from the radiators returns through a buffer tank for DHW heating for further cooling, before it returns to the heat exchanger. However, to maximise the delivered heat from KIWI, the design temperature level 40/25 °C was recommended for the radiators.

Using 60/40 °C leads to much higher energy consumption for the electric boiler, which is inefficient compared to the ground-source heat pump. This is further discussed in the analysis section below.

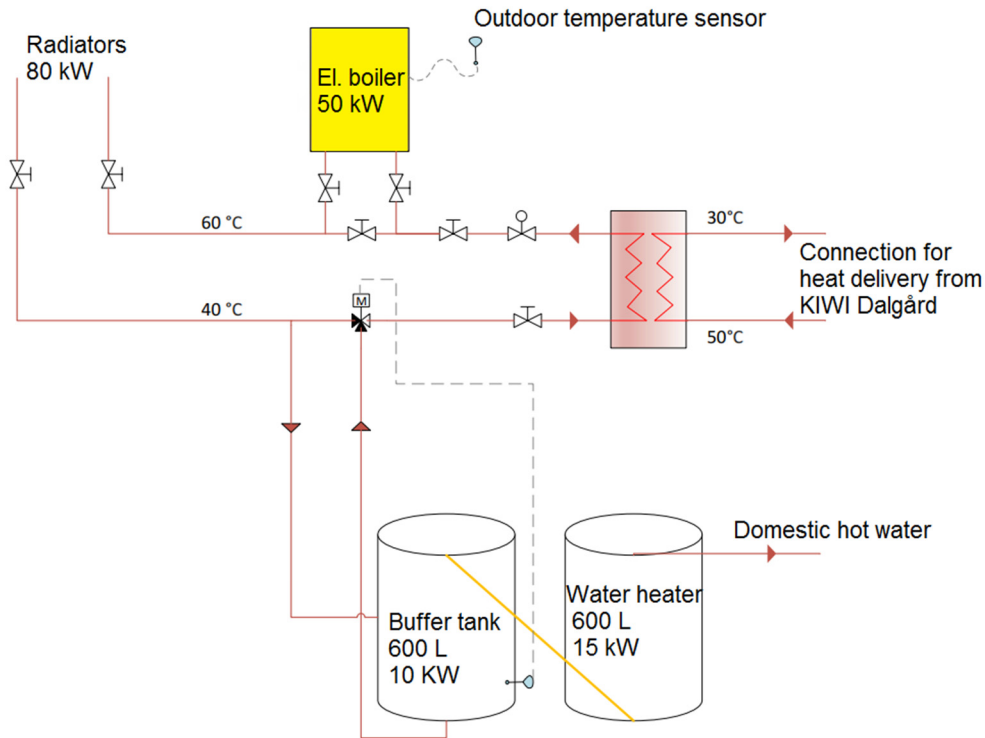

**Figure 16 Principle sketch of thermal energy system at the neighbouring apartment blocks [32].**

During wintertime, the thermal energy system at KIWI Dalgård also provides snow melting outside the store entrance, with a capacity of 70 kW and a design temperature level of 35/20 °C. Temperature and humidity sensors control the system, which is operated between 0 °C and -10 °C. Excess heat that can't be used is given off for street heating or through a dry cooler. The dry cooler was mounted as a backup to reject excess heat but was not intended to be used. Due to issues with utilizing the excess heat at the apartment blocks, it has however been in operation.

The heating system at KIWI Dalgård is monitored by means of eight thermal energy meters and six temperature sensors to optimize the operation of the system as well as to control for errors. The central control and monitoring system provides continuous monitoring and automatically sends alarms if any errors or deviations occur. The heat pump units are controlled based on an ambient temperature compensation curve and by a temperature sensor to maintain the supply temperature between 50-54 °C to activate the thermal storage in the accumulator tank. The peak load should never be used unless the heat pumps are not already running at full capacity. Unfortunately, the central control and monitoring system does not include the thermal energy system at the apartment blocks. This is a separate system operated by another building owner, and there is no control of the heat transfer from the KIWI store based on the demand in the apartment blocks.

The cooling plant for the refrigeration system for freezing and cooler is using CO<sub>2</sub> as refrigerant, which is a highly efficient and environmentally friendly refrigerant for this purpose. The model is a Carrier MiniCO<sub>2</sub>OL Compact with a cooling capacity of 59 kW and a freezing capacity of 20 kW. A measure for reducing the energy use is to recover as much as possible of the gas cooler heat from the cooling plant and use it to heat the ventilation air in the building. The system is also connected to the

borehole system for storage of surplus heat. During the summer, the heat exchangers towards the borehole system are used for cooling CO<sub>2</sub> at transcritical operation, while during the autumn, heat is given off from the gas cooler to the boreholes. These measures are excellent for utilizing surplus heat.

Figure 17 shows a principle sketch of the refrigeration system used at KIWI Dalgård. The numbering in the sketch corresponds to the description of the main components in Table 5.

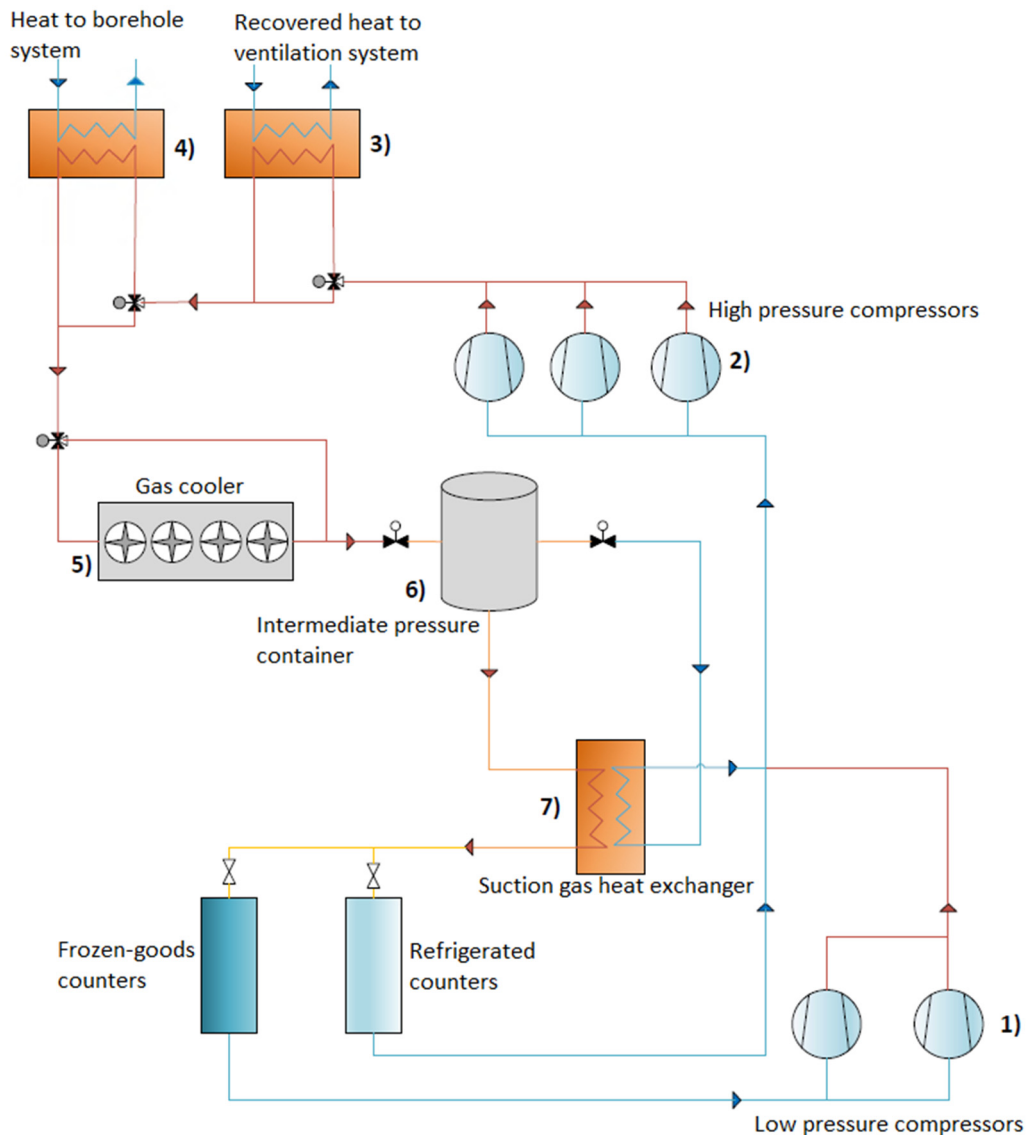

Figure 17 Principle sketch of the refrigeration system at KIWI Dalgård [32].

Table 5 Main components in the refrigeration system at KIWI Dalgård [32].

Nr	Component	Description
1)	Low-pressure compressors	Two compressors for refrigerated counters, whereas one has variable speed drive control. Design evaporation temperature is -35 °C.
2)	High-pressure compressors	Three compressors for refrigerated counters, whereas one has variable speed drive control. Design evaporation temperature is -10 °C.
3)	Heat exchanger connected to the ventilation system	Recovered heat is used to heat ventilation air. Capacity 65 kW and design temperature levels 25/10 °C and 10/20 °C at primary and secondary side, respectively.

Nr	Component	Description
4)	Heat exchanger connected to the borehole system	Recovered heat is given off to borehole systems for thermal energy storage
5)	Gas cooler	Cools the CO <sub>2</sub> and rejects heat to the ventilation air or the borehole system
6)	Intermediate pressure vessel	Contains fluid which is sent to the evaporators. Design temperature is -3 °C.
7)	Suction gas heat exchanger	Ensures dry suction gas to the compressor

The roof and façade of the building are covered with 560 m<sup>2</sup> of solar cells (PV), and the system has an estimated annual electricity production of 56 000 kWh/year. This corresponds to 44 % of the total estimated electricity demand of the store (126 000 kWh). Both traditional crystalline solar cells and thin film solar cells are used, which can be seen in Figure 18. Thin film solar cells are less energy demanding to produce and are expected to generate more electricity during clouded weather. The project received financial support from Enova for testing the thin film technology. IFE (Institute for Energy Technology) will compare the two different types of solar cells in a research project. The solar cells are also connected to a battery pack for storage of surplus electricity. The batteries may also be charged by buying electricity when there is a low strain on the grid.



**Figure 18 Solar cells on the roof of KIWI Dalgård. Left: Thin film and right: crystalline solar cells [32].**

KIWI Dalgård is also using LED (light emitting diodes) for lighting. The lighting system is controlled for daylight in addition to DALI (Digital Addressable Lighting Interface) in the store areas, while other rooms have presence-based control [34]. DALI is an international standard that ensures the building owner/installer free choice of dimmers, relay modules, transformers, control panels and converters [35].

### **Preliminary analysis and discussion**

This sub-chapter includes parts of the master students' analysis as well as some own analysis of the technical solutions used at KIWI Dalgård. *Solutions fitted for surplus energy sources* and *solutions that moderate heating- or cooling power demands* are considered the most relevant criteria from the introduction of this report. As the utilization of surplus thermal energy is dependent on optimal design of the thermal energy systems, some general analysis of the system is included.

### **Refrigeration and freezing systems**



CO<sub>2</sub> is a good choice as refrigerant for refrigeration systems. It is environmentally friendly, as the Global Warming Potential (GWP) is defined as 1 (the reference for other refrigerants). Other common synthetic refrigerants have GWPs of 1430-4000, and as a comparison, the refrigerant R410A used in KIWI Dalgårds heat pump units has a GWP of 2090 [36]. CO<sub>2</sub> is also non-toxic and non-flammable, which is beneficial with regards to safety. While other refrigerants reject heat by condensation of the gas, the CO<sub>2</sub> gas is being cooled in a gas cooler. This is due to the very low critical temperature (31.1 °C), which makes CO<sub>2</sub>-based refrigeration systems especially attractive for heat recovery, as water or other fluids can be heated to higher temperatures [37]. In addition to refrigeration systems, CO<sub>2</sub> heat pumps are also extremely efficient at heating DHW and should be considered for larger buildings with DHW demands, such as apartment blocks, hotels, hospitals, nursery homes and sports centres. The operational pressure is however very high compared to other refrigerants and requires a specific focus in the design and operation of the system. Special routines are also required to avoid the formation of dry ice in refrigeration systems.

The temperatures in the cooling and freezing counters should respectively be 4 °C and -18 °C or lower [38]. The most energy efficient refrigeration plants can maintain these temperatures with evaporation temperatures/pressures at -2 °C/33 bar and -26 °C/16 bar for cooling and freezing counters, respectively. The energy use increases if the evaporation temperature is reduced in order to maintain the temperature levels in the counters. Measured evaporation temperatures during a week in November 2018 is shown in Figure 19. For this time period, the refrigeration plant at KIWI Dalgård operated at -4 °C/31 bar and -28 to -31 °C/13 to 14 bar. There is thus an improvement potential to increase the energy efficiency of the system. By implementing a low-pressure receiver or a suction gas heat exchanger after the evaporators, the full heat exchanger area can be utilized, and no superheating is needed. The refrigerant can then be safely controlled based on the air temperature in the counters and the evaporator temperature increased to -2 and -26 °C. The temperature peaks in the graph occur during defrosting. It is good practice to distribute the defrost cycles of the freezing and cooling systems, so they do not overlap, as simultaneous start of the compressors after the defrost period would require a high power input to reduce the temperature levels in the counters.

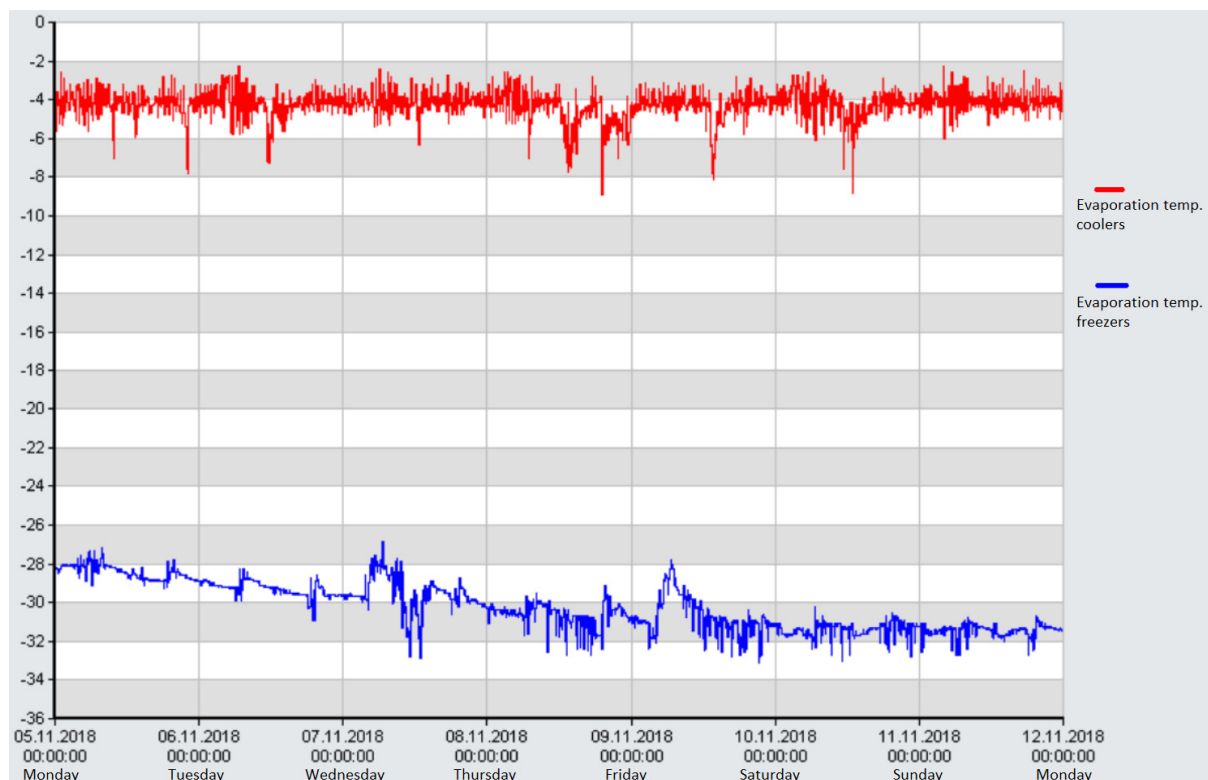

**Figure 19 Evaporation temperatures for the refrigeration plant (cooling and freezing) at KIWI Dalgård during a week in November 2018 [32].**

A transition to natural refrigerants, such as CO<sub>2</sub>, will significantly reduce greenhouse gas emissions from refrigeration systems. Coop tried this with pilot projects in 2009, and the experiences with energy use and later investment costs led to that Coop quickly could introduce CO<sub>2</sub> as the standard refrigerant [27]. The combination of CO<sub>2</sub> refrigeration systems and heat recovery for ventilation is increasingly popular for grocery stores in Nordic countries and can lead to energy savings of about 30 % [39]<sup>4</sup>. If the CO<sub>2</sub> system had used ejectors (now available in standard units) the COP of the refrigeration system would also be higher.

### Utilization of surplus heat

The heating demand of grocery stores is usually low, due to large internal loads from the refrigeration system (freezer, display cabinets), lighting system and persons [41, 42]. If the potential for recovered heat from the refrigeration system is higher than the heating demand of the grocery store, it should be utilized elsewhere. This could be in neighbouring buildings, as for KIWI Dalgård, but also within the same building. As an example, "Sweco-bygget" in Bergen has a MENY-store on the first floor from which office areas on the other floors utilize the surplus heat for heating of domestic hot water. Sweco-bygget is similar to KIWI Dalgård, as it also has passive house standard, has a ground source-heat pump system and solar cells on the roof. It is also rated BREEAM-Excellent, and other environmentally friendly measures involve energy-efficient design of the building envelope, LED lighting controlled both for presence and daylight, adiabatic cooling and demand-controlled ventilation [43].

<sup>4</sup> For more information about utilizing CO<sub>2</sub> in refrigeration systems, see the research project SuperSmart (<http://www.supersmart-supermarket.info/>) or [40] Emerson Climate Technologies, "Commercial CO<sub>2</sub> Refrigeration Systems - Guide for Subcritical and Transcritical CO<sub>2</sub> Applications," 744.com2014, Available: [http://www.r744.com/files/675\\_commercial\\_co2\\_guide.pdf](http://www.r744.com/files/675_commercial_co2_guide.pdf). design guide ([http://www.r744.com/files/675\\_commercial\\_co2\\_guide.pdf](http://www.r744.com/files/675_commercial_co2_guide.pdf)).

Surplus energy is well utilized for covering the ventilation air heating demand in the KIWI store. During the measurement period 01.01.2018-30.11.2018, recovered heat from the CO<sub>2</sub> refrigeration plant amounted to 90 000 kWh, corresponding to an energy coverage factor of 92 % (see Figure 20). This is close to the design coverage factor of 90 %, and the heat pump covers the remaining heating demand. In addition, 70 000 kWh of recovered heat was exported to the borehole system, mostly during the summer months. This is much lower than the design value. It is important to maintain a thermal energy balance over time in the borehole systems, to avoid problems with frozen ground water or sediments, which may damage the pipes. By "charging" the borehole system with excess recovered heat during the summer, the ground temperature will increase before wintertime, which will increase the COP and heating capacity for the heat pump.

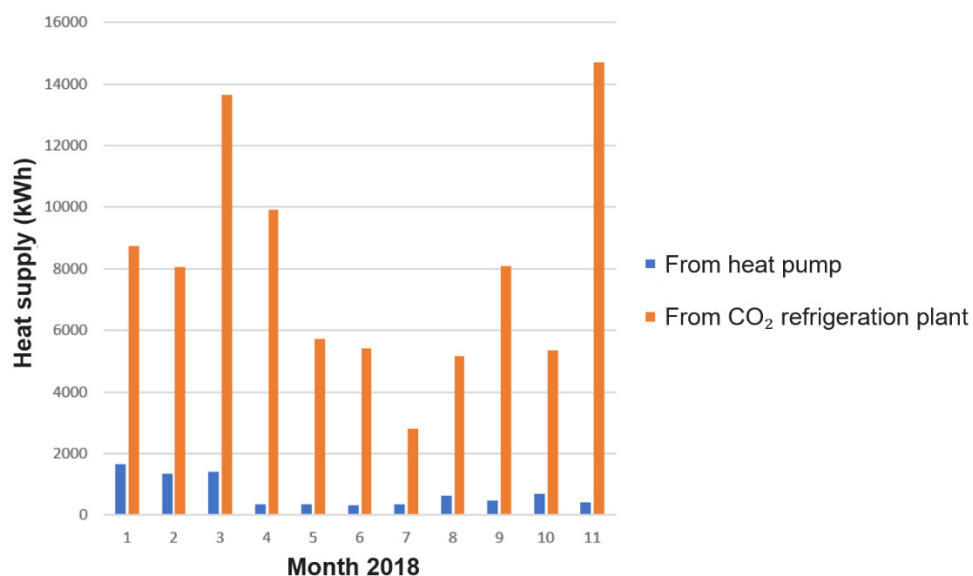

**Figure 20 Ventilation air heating covered by recovered heat from the refrigeration system (orange) and heat pump (blue) [32].**

During the first 11 months of 2018, the heat pump supplied 160 000 kWh to the neighbouring apartment blocks. As the annual design value was 350 000 kWh, this is a considerable deviation. Already before the master student started the work of analysing the thermal energy system, some challenges had already been identified. In addition to purely technical issues such as optimizing both the thermal and electric energy exchange and storage systems, some issues occurred already in the design phase. As the KIWI store and neighbouring apartment blocks had two different building owners and was built by different contractors, the solutions were not properly matched, especially with regards to temperature levels in the thermal systems. The possibility of exporting heat from KIWI Dalgård to the apartment blocks is limited by a higher temperature requirement for the radiators (60/40 °C) in the apartment blocks than what was recommended (40/25 °C). The higher temperature level reduces the heat supply from KIWI Dalgård, which also increases the return temperature and further reduce the efficiency of the system. A lower temperature level would thus increase the average COP (SCOP) of the heat pump system and the capacity for exporting heat from KIWI Dalgård.

### **Borehole system**

The master student has evaluated the borehole system and found that it may be undersized compared to the heating needs of the building. Simulations in Earth Energy Designer (EED) over 25-year periods showed that the potential heat production would be 100 000 kWh/year if no heat is transferred back to the ground, and 130 000 kWh/year if 20 000 kWh is transferred as surplus heat from the gas cooler in the refrigeration plant. This is significantly lower than the estimated potential heat production of 600 000 kWh. At low outdoor temperatures, the heat pump system is running at higher capacity to deliver more heat to the buildings. The return temperature from the borehole system has for these periods been observed to be lower than 0 °C, which is another indication of an undersized borehole system. The temperature of the antifreeze fluid (brine) circulating in the boreholes should not be below -2 °C, as this might lead to freezing of the clay onsite. Freezing and thawing processes could lead to subsidence damage of the collectors. Suggested improvement measures are to increase the number of boreholes or mount temperature sensors on each borehole for improved system control. The measured heat transferred to and from the ground does however indicate that there is a good thermal energy balance in the system, although the capacity is fully utilized.

### **Heat pump system**

The heat pump system is mainly delivering heat to the apartment blocks. The production capacity is however higher than what is possible to utilize due to the higher temperature requirement for the radiators. The measured average COP (SCOP) for the two heat pump units are 3.1 and 3.0, during the first 11 months of 2018. A SCOP of 3 corresponds to an energy saving of 67 % compared to a direct electric heating system. The SCOP is considered moderate, but with a low-temperature heating system at the apartment blocks and more energy efficient heat pump units (from prevailing B to e.g. A<sup>++</sup>), it could have been very good. The two heat pump systems were originally controlled on/off. This led to too frequent starts and stops, approximately 4-5 per hour, which again led to more wear and tear on the compressors and thus shorter lifetime. The control of one of the heat pumps was therefore changed to variable speed drive (VSD), which in addition to reduce wear and tear also leads to higher SCOP and considerably improved controllability at low heating demands. In addition, the accumulator tank for the heating system has been rebuilt to improve thermal stratification.

Regarding the choice of refrigerant, the synthetic refrigerant R410A is not the ideal choice, as Hydrofluorocarbons (HFCs) with large GWPs is planned to be phased out within 2030. This might lead to difficulties for service and maintenance of the heat pump system at KIWI Dalgård. The master student suggests propane (R290) as a better alternative, which has a GWP of 3 [36]. In general, propane heat pumps achieve higher COP and longer lifetime than heat pumps with R410A but requires a larger compressor volume which increases the investment cost. Propane is also a very flammable fluid (safety class A3) and additional safety measures are required. Unfortunately, there is no "ideal refrigerant", and the choice must be made as a trade-off between the advantages and drawbacks of the different refrigerants. However, considering the phase-out of HFCs, natural refrigerants such as CO<sub>2</sub>, propane, and ammonia are considered to be superior options for future heat pump systems in different capacity ranges and application areas.

### **Central control and monitoring system**

The central control and monitoring system at KIWI Dalgård does not include the thermal energy system at the apartment blocks. It would be easier to identify errors and optimization possibilities if everything was monitored in the same system. This is a challenge at the neighbourhood scale that needs to be solved, probably by introducing new business models on how and by whom such interconnected systems should be operated. In addition to not receiving sufficient heat from the heat pump at KIWI Dalgård, the electric heater in the apartment blocks must increase the temperature to the level of the radiators. Based on the design temperature levels, this is a temperature lift of 10 °C, but during operation, this might be different due to the different ambient temperature compensation curves in the systems. In principle, the peak load in heat pump systems should never be running if the heat pumps are not already running at full capacity. For this system, the top load at the apartment blocks is likely to be running during large parts of the year. It has not been possible to verify this, as the student had very limited access to information about the apartment blocks. The refrigeration system at KIWI Dalgård is also controlled by Carrier, whilst Caverion, who operates the rest of the thermal energy system, would like to have full overview and control of this in addition to the ground-source heat pump to optimize the operation of the thermal energy system.

### **Energy efficient lighting**

Using LED for lighting is a measure that falls under the criteria *solutions that moderate heating- or cooling power demand*. In grocery stores, lighting is usually a large source of internal heat gains, as indicated in Figure 21. In addition, the energy use for lighting is usually high [42, 44], as grocery stores utilize extra lighting to make the groceries look more appealing. Most of the stores also have long opening hours, from early in the morning to late in the evening, which also increases energy consumption and internal loads. By exploring daylighting and using LED, both the internal heat gains and energy consumption is reduced, as LED is more efficient than traditional lighting, meaning less energy is lost through conversion to heat. By reducing the internal heat gains from lighting, the power demand for heating will increase in the heating season. However, the cooling demand of the building will also be reduced outside the heating season. Energy use for lighting may also be reduced by control measures, such as turning off the lights outside of opening hours and using daylight control to dim the lights, whenever the daylight is sufficient. Presence-based control is more relevant for other building types with more intermittent use, such as offices and residential buildings.

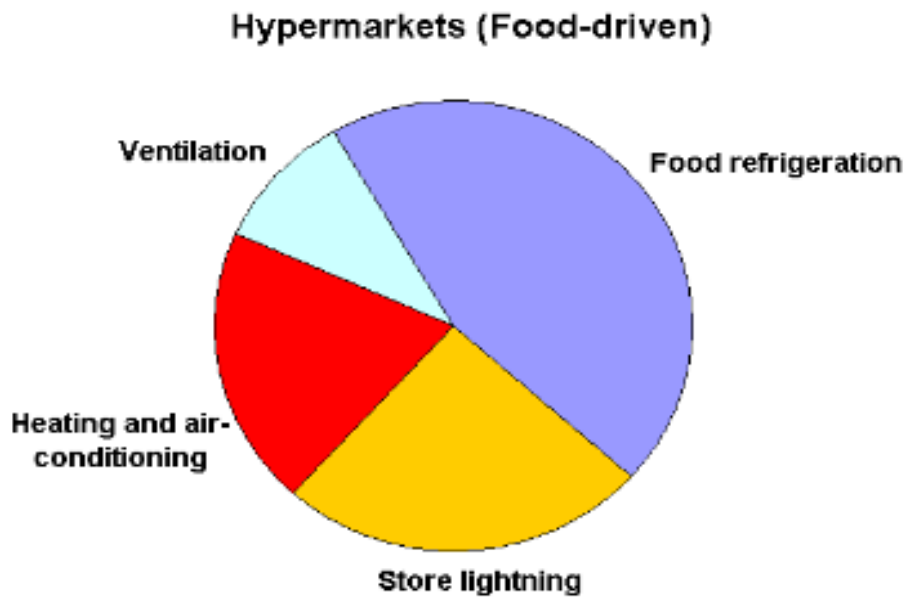

**Figure 21** Distribution of typical energy use in hypermarkets (food-driven) [44].

Commercial buildings (Norwegian: Forretningsbygninger) are among the building types with the highest specific energy use [45]. The standards for energy calculations, NS 3031:2014 and SN TS 3031:2016, provide estimated values for typical energy use for lighting systems in different building types [42]. With 56 kWh/(m<sup>2</sup>·yr) commercial building type has the highest value of all categories. The standards also state that if a control system is used based on either daylight or presence, the energy consumption can be reduced by 20 %. It is also possible to document other values for lighting through calculations according to NS-EN 15193 or similar.

The technology development for lighting the recent 10-15 years have led to considerably more energy efficient lighting system. This has reduced the energy use for lighting without depreciating the perceived quality of the lighting [46, 47]. Before the introduction of LED, fluorescent lighting was the standard solution in commercial buildings, as it's suitable for illuminating large indoor areas. Fluorescent lighting is also quite energy efficient compared to other light sources, and there has also been a development with this light source. It has become common to replace fluorescent tubes of the type T8 with mechanical starting switch to T5 with electronic starting switch. There is also an increased focus on control systems for lighting, and this trend is expected to continue in the years to come [26]. A short article by Karmakar, et al. [48] compares energy efficiency, environmental impact, lifetime, costs and performance for LED tubes vs fluorescent T5 lighting. It found that for illuminating large areas, the energy consumption was the same for the two types when providing the same brightness of the light (lumens). This is because LED is more suitable for spotlighting. The article also found LED to be more environmentally friendly due to the mercury in fluorescent tubes, and to have a longer lifetime (10-15 years vs 3-4 years), albeit higher investment costs.

### **Measured energy use**

The energy need of KIWI Dalgård was estimated to be 126 000 kWh/year. During the first 11 months of 2018, the measured energy use was 284 723 kWh, i.e. more than two times higher. The energy use for the different purposes is shown in Figure 22. The cooling plant is clearly the largest single consumer

of energy, using approximately 100 000 kWh, close to the estimated total energy need for a full year. If "Cooling counters plug-in" is included, i.e. free-standing cooling counters in the store, the refrigeration system for groceries alone amounts to approximately 140 000 kWh. This is higher than the estimated annual energy need, while still missing the December month to make it a full year. It is not clear what is meant by the energy use of "Solar cells" in the graph, but the energy production from the solar cell installation is said to be much higher (although not quantified), so this should be disregarded.

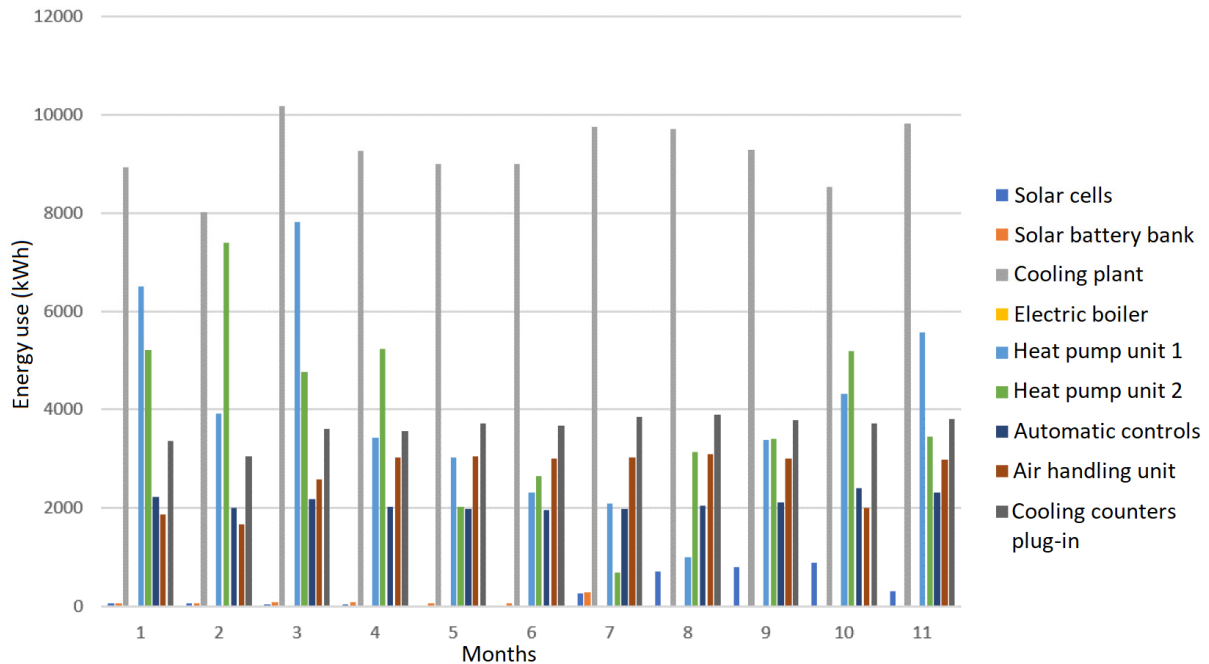

Figure 22 Measured energy use at KIWI Dalgård during 01.01.2018-30.11.2018 [32].

### Conclusions and need for further work

KIWI Dalgård is designed to be a very environmentally friendly building and should be considered a role model for future grocery stores, albeit still having a potential for improvement. The design of the building and technical installations is very good, except for the issues with relatively high temperature requirements for the radiators in the apartment blocks that receive surplus energy from the ground-source heat pump. Also, the energy class for the heat pump units is only B and the use of A<sup>++</sup> units would increase the SCOP. The best available heat pump technology should be used, not old and inefficient technology. It is however still early to properly evaluate the thermal energy system at KIWI Dalgård, as the first operating year of buildings usually involves higher energy use and some modifications and adjustments on the system to optimize it. If the borehole system indeed is undersized, this will, however, be a major drawback limiting the potential for exported heat. The holistic approach including environmentally friendly materials and solutions for zero emission transport is also of utmost importance to create zero emission neighbourhoods.

A lack of cooperation between the building owners and designers/contractors at KIWI Dalgård and the neighbouring apartment blocks led to a mismatch of the temperature levels and sub-optimal operation of the thermal energy systems. This is related to both the export of surplus energy from the borehole system to the apartment blocks, the operation of the electric top load in the apartment blocks and monitoring/control of the thermal energy system. These issues should be solved for future projects with energy exchange at neighbourhood scale.

In addition to recover surplus heat from the refrigeration and freezing systems in grocery stores, it is important to first minimize the energy consumption for this purpose. It is first during the recent years that mounting doors on the refrigerated/frozen-goods counters have become common in new stores. Another simple measure to save energy is to cover the counters outside of the opening hours. The potential for energy savings through minimizing the cooling demand by such measures are considered to be high [26] and should thus be implemented in all grocery stores, not only new ones. Properly designed CO<sub>2</sub> refrigeration systems will then cover the remaining energy demand in a highly efficient manner.

For KIWI Dalgård the following further work is planned:

- The master student analysing the thermal energy system delivered her project assignment by the end of 2018. A more detailed analysis of the heating system will be included in a report summarizing field measurements of thermal energy systems in nearly zero energy buildings within IEA HPT Annex 49. This report is expected to be published in the first quarter of 2020.
- Solar cells are mounted both on the roof and the facades. 30 % are traditional crystalline solar cells, and 70 % are thin film (CIGS) solar cells. The performance of the thin film solar cells compared to crystalline solar cells will be evaluated during the next couple of years by the Institute for Energy Technology (IFE).
- The control method for the battery pack for the solar cells is not yet solved, regarding when the batteries should be charged and discharged. Within FME ZEN, the introduction of energy storage and smart control methods is considered to be an important measure to reduce peak power periods in the grid. This topic will also be increasingly relevant to reduce costs when the new tariffs for grid rent are implemented. There has been a lot of discussion and several hearings with suggestions the recent years, and the new grid rent is currently planned introduced in 2021 [49].



## Appendix E: Climatization of residential buildings

This section considers simplified space-heating distribution in highly-insulated residential buildings. The different building categories should be investigated separately when considering simplified space-heating distribution, typically residential and office buildings behave differently regarding simplified space-heating distribution. Firstly, the desired indoor thermal environment in residential buildings is specific. In such buildings, indoor temperatures are expected to be different between rooms, especially bedrooms. Secondly, in residential buildings, internal gains and ventilation airflow rates are relatively low compared to office buildings. Consequently, one cannot extrapolate directly results from a given building category to residential buildings. The working hypothesis of this section is that the building is highly-insulated and equipped with balanced mechanical ventilation with efficient heat recovery. Recently, research has been performed in Norway regarding simplified space-heating distribution in residential buildings. These researches addressed space-heating using a limited number of radiators, air-heating and wood stoves.

The **research questions** were the following:

1. Using standard space-heating distribution loops, it is typical to have many heat emitters in the same room if this room is large or have many windows. Radiators were typically positioned below windows to prevent cold draft as well as cold internal surfaces. If not removed, these physical factors could result in discomfort for users located in the vicinity of the window (or a cold external wall). As external walls and windows are more performant in highly-insulated buildings, it is not necessary to place a radiator in front of each window. This is at the basis of the definition of the German Passive House standard [50]. Therefore, a large room could be heated using a single heat emitter. The research question was to investigate **temperature differences and thermal comfort in a room equipped with a single heat emitter (Q1)**.
2. With simplified space-heating, some rooms will have no heat emitter at all. Some heat emitters will have to guarantee thermal comfort for several rooms. Temperature differences will unavoidably appear between these rooms. The research question is to **document the typical temperature differences generated between rooms using simplified space-heating (Q2)**. Configurations with at least one heat emitter per floor were analysed. The case of a single heat emitter for several floors has been considered in a limited number of cases. With hydronic distribution, radiators are typically placed in the living room and/or a corridor while bedrooms have no heat emitter. With air-heating, the space-heating is performed using mechanical ventilation and hygienic ventilation airflow rates. As bedrooms have a ventilation air supply, they will be heated directly while corridor will be heated indirectly by the cascade flow within the building. Consequently, temperature differences generated by a limited number of radiators and air-heating are different.
3. The indoor thermal environment in bedrooms was also questioned. If bedrooms have no heat emitter (and if air-heating is not applied), they typically have a lower temperature than neighbouring heated rooms. With current air handling unit (AHU) technology, the ventilation air supply has the same temperature for the entire building, a so-called “one-zone” ventilation. This tends to homogenize heat inside the building. In terms of user behaviour, many Norwegians are known to prefer relatively cold bedrooms (typically in the range of 14-18°C or lower). There is thus a risk of window opening if the resulting bedroom temperature is too high. **The research question is to analyse the bedroom temperature in highly-insulated buildings (with one single air supply temperature) and simplified distribution, as well as the user behaviour especially regarding window opening (Q3)**. Opening windows flushes a significant amount of energy to outdoors and can significantly impact the energy efficiency of the building.
4. The last aspect is less related to the space-heating distribution but more to the thermal dynamics of the building envelope. The time constant of highly-insulated residential buildings is relatively long (from one to several days). In other words, **these buildings take a relatively long time to**

**react to a change of temperature set-point (Q4).** Quick decreases of the indoor temperature are almost impossible to obtain. On the one hand, some users can expect these quick variations to be possible. For instance, it could be expected that a bedroom is used for homework (or an activity) during daytime with a temperature of  $\sim 21^{\circ}\text{C}$ . This same bedroom can be used a couple of hours later for sleeping with a significantly lower desired indoor temperature, like  $\sim 16^{\circ}\text{C}$ . Firstly, as the building is slow to react, such a quick decrease of the bedroom temperature would require a window opening. Secondly, if the bedroom has no heat emitter, the available power to reheat the room (after a period of low indoor temperature) is limited. These aspects mostly related to the building thermal dynamics have not been analysed extensively in the past.

Recent studies performed about simplified space-heating in highly-insulated Norwegian residential buildings are listed in Table 6. This document aims at summarizing results and cannot be exhaustive. The reader is invited to consult the different articles and reports listed in the table for extended explanations. In each case analysed, the bathroom is heated using floor heating.

**Table 6 Summary of recent studies investigating the indoor thermal environment in Norwegian highly-insulated residential buildings (with balanced mechanical ventilation equipped with heat recovery and simplified space-heating): the specific research questions (meaning Q1 to Q4, introduced in the previous section) addressed by these works are marked by a cross (x).**

Study	Method	Typology and number of cases	Space-heating and ventilation	Q1	Q2	Q3	Q4
Berge [51]	User survey, questionnaire, measurements	34 flats (passive and low energy)	One radiator per floor and one-zone ventilation	x	x	x	
Berge [52]	User survey, questionnaire	62 row houses and detached houses	One radiator per floor and one-zone ventilation	x	x	x	
Berge [53]	Simulations	1 flat	One radiator per floor, one-zone vs. two-zones ventilation		x	x	
EBLE [54]	Simulations, interview and measurements	64 passive houses and 10 TEK10 houses	Various space heating and ventilation configurations			x*	
Georges [55]	Simulations, interview and measurements	2 flats	One radiator per floor and one-zone ventilation	x	x	x	x
Georges [56]	Simulations, interview and measurements	2 row houses	One radiator per floor and one-zone ventilation	x	x	x	x
Selvnes [57]	Simulations	1 detached house	One radiator per floor and one-zone ventilation, with or without cascade	x	x	x	
Georges [58]	Simulations	1 detached house	Air heating with one-zone ventilation		x	x	
Georges [59-61]	Simulations	1 detached house	One wood stove for the entire building and one-zone ventilation	**	x	x	
Georges [61]	Measurements and simulation	1 row house, unoccupied	One wood stove for the entire building and one-zone ventilation	x	x		

Study	Method	Typology and number of cases	Space-heating and ventilation	Q1	Q2	Q3	Q4
Peng [62]	Measurements	1 detached house (ZEB Living Lab), unoccupied	One radiator per floor and one-zone ventilation	x	x	x	x
Woods [62]	User interview	1 detached house (ZEB Living Lab) occupied	Floor heating and one-zone ventilation			x	x

\* In EBLE (Evaluation of housing with low energy needs) we analysed the performance of 64 new Passive Houses and 10 new TEK10 houses. EBLE looked at temperatures but also considered energy use and building process.

\*\* overheating only due to stove power oversizing



**Figure 23 Typical configuration investigated with one-zone ventilation and a radiator (in yellow) placed in a central position. Picture of the apartment block investigated in Miljøbyen Granåsen (image: Interiørfoto [62]).**

### Temperature distribution in living areas (Q1)

Again, research has been performed in configurations with a least one heat emitter per floor and one-zone ventilation. In other words, the case with a single emitter to heat several floors was not targeted and has been investigated in a limited number of cases. Regarding the room where the radiator is placed, both measurements and user surveys confirmed that the thermal environment is comfortable. For the same height, horizontal variations of air temperature are limited. The vertical temperature stratification is also within acceptable limits according to ISO 7730:2015 [63]. Simulations are not able to address this question (Q1) because these commercial building simulation tools systematically assume that each room is isothermal [64]. Temperature distribution cannot be investigated with commercial building performance simulation tools, another type of modelling approaches should be used, such as Computational Fluid Dynamics or zonal models, but it was beyond the scope of the research. Regarding user surveys and interviews, a very large majority reported a high degree of satisfaction regarding living areas, such as the living room. Consequently, there is a relatively high level of confidence that a single heat emitter provides the desired thermal environment in the room where it is placed. In addition, the different investigations showed that people would like indoor temperature of living areas in the range of 22-24°C and not the 21°C traditionally assumed in thermal comfort or energy evaluations.

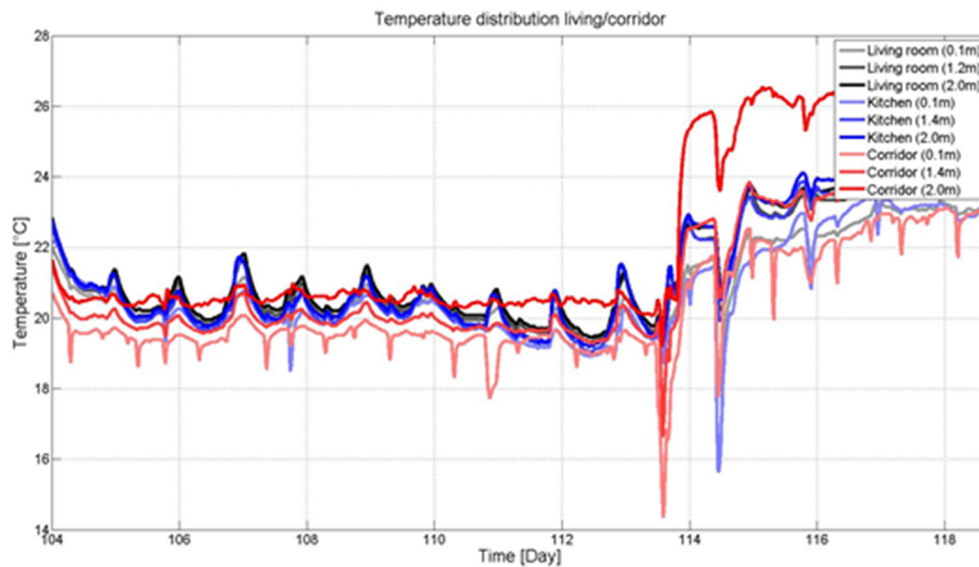

**Figure 24 Measured temperature distribution in a flat heated by a single radiator located in the corridor (the occupant is back on the day 114) [65].**

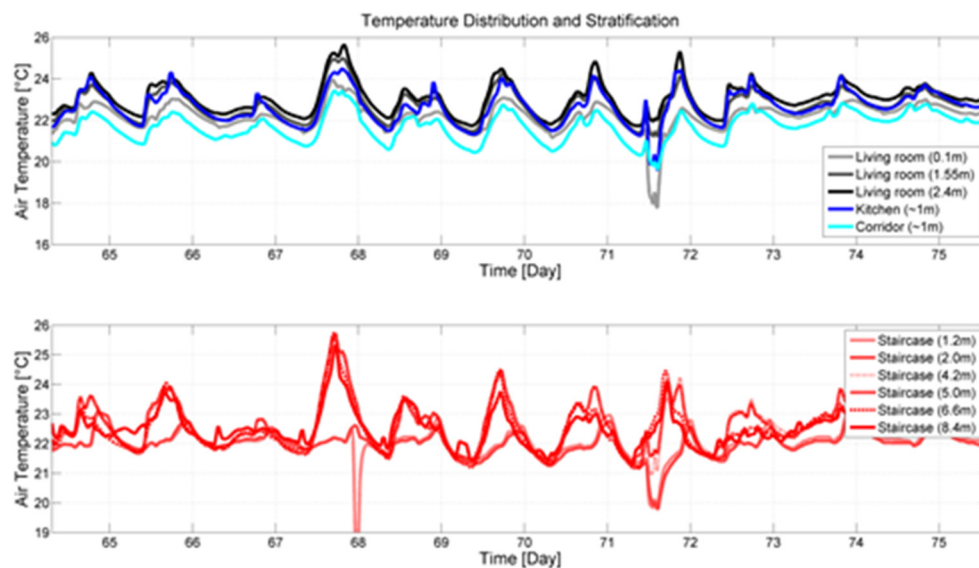

**Figure 25 Measured temperature distribution in a row house heated by a single radiator per floor (located in the living room or corridor) [56].**

Regarding air-heating, investigations were only performed using building performance simulations (here TRNSYS [66]). The temperature distribution inside a room is thus not investigated. The influence of the air supply temperature on the ventilation efficiency is not covered as well.

Regarding space-heating using wood stoves, a key challenge is overheating. Using the standard combustion strategy of wood stoves, their nominal power ( $P_n$ ) cannot be easily decreased below 3-4 kW without degrading the combustion performance. Therefore, the minimal  $P_n$  available in the market is in the range of 3-4 kW. For highly-insulated buildings, there is thus a risk of overheating in the room where the stove is placed. Simulations [59, 60] and measurements [61] have shown that this risk is limited if the stove nominal power is selected in an appropriate way according to the building properties (including

the insulation level and the thermal mass). For instance, wood stoves with a Pn of 4 kW and 50% power modulation capabilities would not generate overheating in many Norwegian passive houses. The development of a simple power sizing procedure of wood stoves for a given building category (i.e. age, typology, construction type, location) is under development. With high operative temperatures, it has also been measured that the thermal stratification can be non-negligible and impact negatively thermal comfort.

### Temperature differences between rooms (Q2)

It is difficult to give exact numbers for this question. Each building is different, for instance with a different floor plan and construction modes (influencing the thermal mass of the building as well as the insulation of external walls and internal partition walls). Buildings that were investigated using measurements are lightweight. Consequently, partition walls inside the building are insulated to prevent noise propagation between rooms. Conclusions that are given here are thus valid for this category of buildings.

For simplified space-heating using a **limited number of radiators** and one-zone ventilation:

- With open internal doors (and closed bedroom windows), the temperature differences between rooms can be kept at  $\sim 1^\circ\text{C}$ . This difference can be higher in the presence of high solar gains, but this influence of solar gains holds true for any kind of building (not only buildings with simplified distribution).
- With closed internal doors (and closed bedroom windows), the temperature differences between heated and non-heated rooms range between  $2\text{--}4^\circ\text{C}$ , depending on the building floor plan and the outdoor temperature. The temperature differences between rooms are lower for milder outdoor temperatures. With  $2\text{--}4^\circ\text{C}$  temperature differences, it means that with a living room at  $\sim 22^\circ\text{C}$ , the bedroom cannot reach temperatures lower than  $18\text{--}20^\circ\text{C}$ , see Figure 26.
- Larger temperature differences can be generated if the bedroom door is closed and the window opened for several hours, see Figure 27. Then, temperature differences of typically  $4\text{--}8^\circ\text{C}$  can be created. The temperature in bedrooms can thus reach the level of  $\sim 16^\circ\text{C}$  with a living room at a higher temperature.

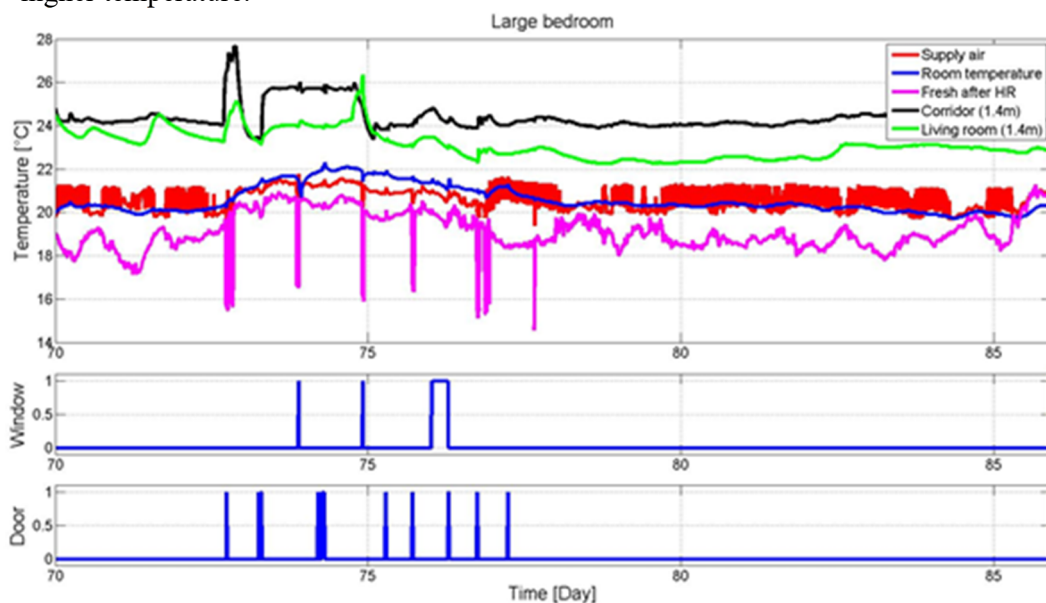
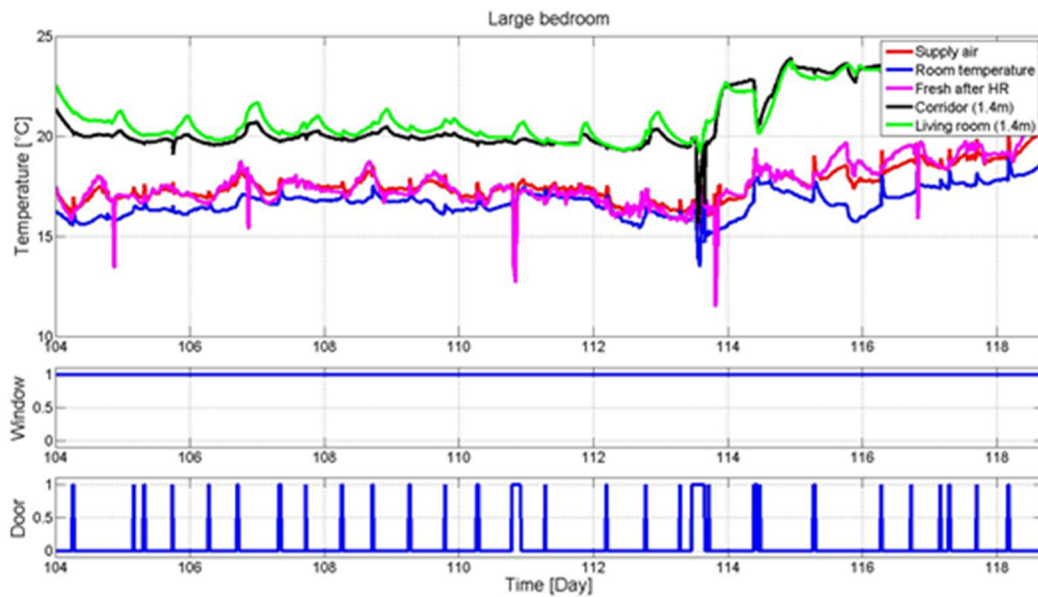

Figure 26 Measured temperature distribution in an apartment heated by a single radiator in the corridor, the open/closed state of the bedroom door and window is shown in blue in the last two graphs [65].



**Figure 27 Measured temperature distribution in an apartment heated by a single radiator in the corridor, the open/closed state of the bedroom door and window is shown in blue in the last two graphs [65].**

Detailed dynamic simulations [58] have been performed on a detached house typology to investigate the potential of **air-heating** in Norwegian passive houses **using one-zone ventilation**. The maximum allowed air temperature was taken as the temperature before carbonization of dust, meaning  $\sim 50$  °C. It has been shown that the necessary temperature for the supply ventilation air would be acceptable for most of the locations in Norway (such as Bergen, Oslo and Tromsø, but not Karasjok because it would require temperature of the ventilation supply air above 50 °C). Nevertheless, temperatures in the bedroom are significantly higher than the rest of the building, especially bedrooms with a double bed (requiring  $52 \text{ m}^3/\text{h}$  of fresh air). This situation is not improved by the location inside the building of the temperature sensor that controls the air-heating coil.

### Temperature in bedrooms and window opening (Q3)

It has been shown that creating large temperature differences is difficult (or even impossible) with highly-insulated building envelopes and one-zone ventilation (cf. Q2). There is thus a risk of window opening to create low temperatures in bedrooms. User surveys and measurements confirmed that a significant number of occupants would like a cold bedroom and use window opening during several hours every day (in winter time) to reach these lower temperatures [51, 52]. It has been shown that the motivation for window opening is not the Indoor Air Quality (IAQ) but temperature control. Opening windows to control bedroom temperatures is not recommended as it will impact the energy efficiency of the building.

This effect of window opening on the space-heating needs has not been measured but investigated using detailed dynamic simulations. Simulations in IDA-ICE have a so-called “ventilation network” embedded with the building model that enables to evaluate airflow between zones (or outdoors), through doors, cracks or windows. These simulations have been performed on different building types [56, 57, 65] (i.e. apartment, row house, and detached house) with the same conclusions. Opening windows to control the bedroom temperature leads to a significant increase of the space-heating needs of the building. It depends on the way the building is controlled but this increase of the space-heating needs

was estimated in the range of 40-80%. This effect is particularly challenging to simulate because many important input factors for the simulation are difficult to access and thus to provide to the simulation (such as high-resolution wind speed and direction on site, the pressure coefficient on the building facades, the fraction of the window area that is opened or the corresponding discharge coefficient, Cd). Consequently, these simulated values of increased space-heating needs should be considered as an estimation. However, to the authors' opinion, nothing more accurate has been proposed in the literature in equivalent conditions: it is indeed difficult to consider the conclusions from other European countries as the climate is different and the desired indoor temperature in bedrooms as well.

Measures to provide cold bedrooms without impacting the energy efficiency too severely have been investigated:

- Measurements and user surveys have shown that many people that desire lower temperatures in bedrooms do not operate the air-handling unit (AHU) in a coherent way. The temperature set point for the air-heating was set too high so that heating of the ventilation air was performed for a significant part of the winter. It was then worth investigating if a **proper control of the system** (still based on one-zone ventilation) would be able to provide cold bedrooms without impacting energy efficiency. Different controls based on different temperature set points for the supply air and controls of bedroom windows have been compared using simulation. Again, different building types have been analyzed (meaning apartments, row and detached houses) [56, 57, 65]. The conclusion is that none of the controls was able to provide lower temperatures in bedrooms without degrading energy efficiency significantly. Therefore, it can be concluded that the problem is not related to the user behavior but on the building concept (especially the one-zone ventilation strategy).
- Using the same simulation setup, the **influence of the thermal insulation of partition walls** have been analyzed [57]. As already mentioned, with lightweight constructions in wood, partition walls are already insulated for acoustic reasons. Most of the temperature zoning effect is already performed by this default insulation thickness. Simulations show that adding extra insulation has a minor effect on temperature zoning. On the contrary, increasing the thickness of partition walls could be experienced as negative due to the space required by such measure.
- It is technically possible to place a **buffer zone with an intermediate temperature** between living areas at a higher temperature (~21°C) and bedrooms. Nevertheless, given the price of real estate per square meter, it is unlikely that owners agree to sacrifice floor area within their building to create temperature zoning. Even though effective from a technical point of view, this solution is unlikely to be universally accepted by building occupants.
- **Two-zone ventilation** has been investigated by Berge et al. [53] using building performance simulation (here IDA ICE). Unlike one-zone ventilation, two-zone ventilation supplies ventilation air at two different temperature levels: higher temperature in living areas and lower temperature in bedrooms, see Fig. 6. Simulations show that the system enables to reduce the risk of window opening and improves the energy efficiency of the building.
- Instead of creating temperature differences between rooms to prevent window opening, an alternative strategy is to limit the negative impact of window opening on the space-heating needs. A main reason for the increase of space-heating needs due to cold bedrooms is due to the cascade ventilation. Bedrooms have a supply ventilation air of 26 m<sup>3</sup>/h per person. If the bedroom is cold (for example with a temperature of 16°C), this air is transferred to a corridor before being extracted in a wet room. During this travel, the air will be heated to the higher temperature of living areas (meaning 21-24°C). If bedroom doors are closed, this effect causes a main increase of the space-heating needs due to the opening of bedroom windows. The concept of cascade ventilation needs thus to be questioned. If the **ventilation is balanced at the level of each bedroom (non-cascade ventilation)**, meaning supply and exhaust performed locally, the impact of window opening can be reduced (if bedroom doors are kept closed). It required an extra amount of ventilation air as zones that were previously transit zones in cascade

ventilation (typically corridors), would require a dedicated supply of fresh air. Selvnes [57] has shown using simulations that this strategy reduces the effect of window opening on the space-heating needs compared to the traditional cascade ventilation. Again, a condition is that bedroom doors should be kept closed if bedroom windows are open. This “low-tech” approach requires limited modifications of the ventilation system.

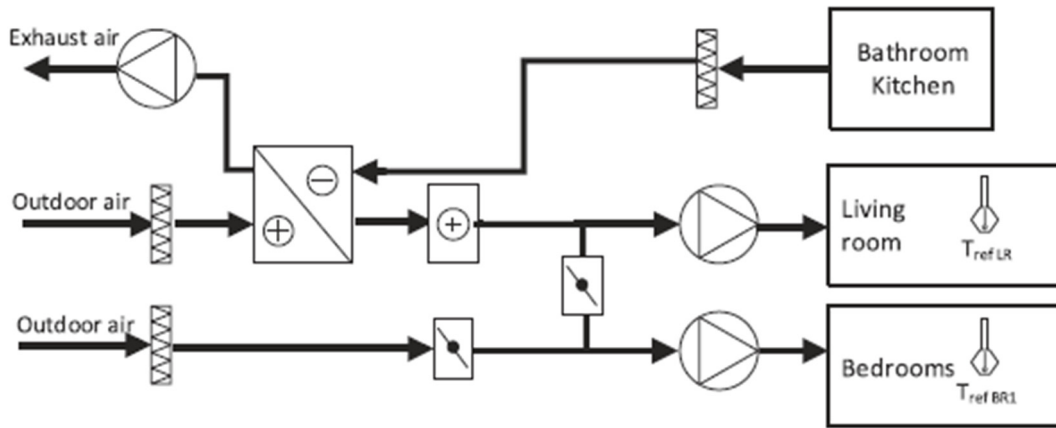

**Figure 28 Schematic diagram of the alternative two-zone ventilation with reference temperatures in the living room and in one bedroom [53].**

From user surveys, the lack of heat emitters in bedrooms has been experienced as negative by a very limited number of occupants. In addition, simulations have shown that it is possible to get warm bedrooms (meaning  $\sim 21^{\circ}\text{C}$ ) by slightly increasing the temperature of the ventilation air supply.

### **A holistic research project on highly-insulated houses (EBLE)**

Most of the studies listed in Table 2 mainly focused on the indoor thermal environment, considering the simplified heat distribution and the temperature zoning (including lower temperatures in bedrooms) [54]. However, some important Norwegian research projects were wider in scope. The project EBLE (Evaluation of housing with low energy needs) analysed the performance of seven Passive House projects and two projects with ordinary houses built according to the Norwegian building code [67], also considering energy use and building process: this corresponds to 64 new Passive Houses and 10 new TEK10 houses. It is the most comprehensive study that has been carried out in Norway related to this subject [68].

Regarding indoor thermal environment during the heating season, some important findings and confirmations of EBLE can be first listed:

- The measurements show that houses in the various projects **fulfil the desired indoor temperatures**. Some exceptions were reported due to technical challenges with the heating systems. In these cases, measures to increase the temperatures was deployed.
- Choice of heating system was by most developers considered as a challenge.
- The measurements show that there are greater differences in indoor temperatures between houses within one project than differences between different projects.
- EBLE strongly supports conclusions from the other studies. The desired living room temperature was **higher than the reference temperature** used for energy calculations according to current standards. There was also a general desire to **lower the temperature in the bedrooms**. It was seen challenging to differentiate the temperature between different rooms inside the building. Window airing is used to lower the temperature in bedrooms.



Some complementary findings of EBLE regarding the indoor environment in general are worth to be mentioned:

- The residents of both Passive and TEK10 houses have high expectations related to the indoor climate and thermal comfort. These expectations are largely fulfilled. This also been confirmed by the work of Berge [51, 69].
- **Low relative humidity** and perceived dry air during winter season is a general problem indoors. This is caused by high air change rates in combination with low humidity contribution from interior activities.
- Findings show that most of the residents are **pleased with the experienced indoor temperatures** both during the summer and winter period.
- Results show that the use of **exterior window shading and aeration of the dwelling** reduces the risk of too high temperatures in summer.

Some important EBLE findings regarding highly-insulated buildings are given here below:

- **Energy use is clearly dependent on the user behavior and habits.** The energy use measured within projects with the same technical specifications varied widely, showing the great impact that the user's behavior has on energy use. However, taking into account all measurements from PH and TEK 10 houses, the average shows a significantly lower energy consumption in Passive Houses than in ordinary houses built according to the TEK10 standard. In average, the energy consumption of the Passive Houses was 30% less than for the TEK10 houses. Estimated requirements for delivered energy is in average 23% lower than the measured delivered energy for Passive Houses and 4% lower for TEK10 houses.
- **Residents demanded easily accessible information about control, regulation and maintenance of the technical installations**, especially where the technical solutions were innovative and unfamiliar to users. Dissemination of information and follow-up was not well taken care of in all the projects. This is confirmed by the other studies, see e.g. [56].
- The developers consider that the increased **focus on energy savings and airtightness measures has improved the quality** of the buildings in general.
- The entrepreneurs report consistently **increased time and costs** in the construction of Passive Houses. The increased time use for construction is mainly related to wall construction with thicker insulation layers and high demand to air tightness. The largest cost increase is therefore caused by the exterior wall construction including more materials, more expensive windows and increased construction period [70].
- In seven of the buildings, wood moisture content of the wall and roof constructions were measured as well. The measurements of wood moisture content in all cases confirm that Passive Houses are a moisture safe construction, if built according to known principles documented in [71].

## Conclusions and need for further work

Based on the experience in Norwegian residential buildings, the simplified space-heating using a **limited number of radiators** looks effective to ensure the desired thermal environment in the rooms where the radiators are placed, even if these rooms are large. The indoor temperature in non-heated bedrooms is a balance between heat conduction through internal walls, internal gains and the effect of the one-zone balanced mechanical ventilation. For lightweight buildings, the typical temperature difference generated is 2-4°C between the heated living areas and non-heated bedrooms (with closed internal doors). The risk for opening bedroom windows to generate lower bedroom temperature (< 16°C) is thus critical. This has been confirmed by measurements, user surveys, and interviews. Further work is required in this area:

- The **number of measured buildings and users** involved in previous studies is still limited (~100). If the question of bedroom temperature should generate new practices and lead to new products from the building industry, conclusions should be consolidated with a larger panel of users and measurements. **In addition, the relation between window opening and the corresponding increase in space-heating needs** has been so far investigated using detailed dynamic simulations. For a full demonstration of this effect, field measurements are required with detailed monitoring of window and internal doors openings, indoor temperatures and energy use for space-heating over a long period of time (meaning at least one heating season).
- It has been showed that control is not enough to generate cold bedrooms with one-zone ventilation without degrading energy efficiency significantly. Changes of the building concept should be considered. **Modification of the ventilation strategy looks like the best option.** In that respect, different solutions have been proposed, such as two-zone ventilation or balanced ventilation at the level of bedrooms (non-cascade ventilation). Detailed dynamic simulations proved these solutions to be efficient. **These new techniques should be further analyzed with field or laboratory testing.** Other solutions may also be proposed. For instance, decentralized ventilation is an option. Nevertheless, the heat recovery efficiency of such devices outside laboratory conditions is often questioned. In addition, the noise they generate in a bedroom can be problematic. If alternative ventilation strategies should be considered, the question of the **low relative humidity should ideally be combined.** Many strategies can be investigated but it requires moving from simulations to field or laboratory testing.
- The basic assumption done in many studies is that people do not adapt. In other words, if they open windows today, they will do it in the future. Nevertheless, it is not proven that, over a long period of time, people will not accept warmer bedrooms and adapt. This is also a question of habits and culture, not only buildings physics. The **potential for adaptation** should be investigated. If this potential of adaptation appears to be limited, technical solutions should be found.
- Only a very limited number of occupants experienced as negative the absence of heat emitter in bedrooms. High temperature can be created in bedrooms (~21°C) by slightly increasing the temperature of the supply ventilation air. Again, this has been investigated using simulations and not in the field. This simple solution would nonetheless prevent to have simultaneously some bedrooms at a high temperature and some others at a low temperature. It should be investigated if this **lack of flexibility** can be experienced as negative by users or not. User surveys are efficient tools to answer this question. Regarding flexibility to users, the last research question (Q4) regarding the slower thermal dynamics of highly-insulated buildings (and its impact on window openings and user satisfaction) has been overlooked and deserves more research.

If one-zone ventilation is applied, **air-heating with one-zone ventilation** does not look appropriate for Norwegian residential buildings because it would generate high temperatures in bedrooms. Consequently, we end up with a paradox. Air-heating is attractive because of its simplicity and the opportunity to reduce investment costs for the space-heating distribution system (like water-based heating). Nevertheless, this approach would generate relatively warmer bedrooms so that more sophisticated ventilation strategies are required to make air-heating acceptable, possibly removing the gains from the simplification.

### Complementary questions

Other challenges are connected to the previous questions but have not been addressed in the past.

- Firstly, in a balanced mechanical ventilation system, bathrooms are typically extraction zones with a relatively large amount of air extracted. Bathrooms have also higher indoor temperatures so that a large amount of air is heated at a higher temperature in bathrooms just before entering the heat recovery unit and leaving the building. In addition, it is also proved that floor heating

in bathrooms is often applied all year round, including summer [51]. Improvements based on space-heating and ventilation systems could be investigated to solve these challenges.

- Secondly, when the energy efficiency of the building and the ventilation heat recovery are evaluated, it is most often done assuming a uniform temperature inside the building. In practice, temperature differences will appear inside the building. With a centralized heat recovery and one-zone ventilation, these temperature differences decrease the overall efficiency. In other words, if each room had a decentralized heat recovery with an effectiveness  $\alpha$ , the space-heating needs would be lower than a centralized heat recovery with the same effectiveness  $\alpha$  due to the temperature differences between rooms. For example, cold bedrooms could get ventilation air supplied at a too high temperature. On the contrary, warmer areas could get ventilation air supplied at a too low temperature (because the extracted air has been mixed with all the rooms and cooled down by the colder rooms of the building). This new research question has been introduced recently in the ventilation research community.

## Appendix F: CommONEnergy: Shopping centres

This chapter is based on a large EU-project on shopping centres (CommONEnergy)<sup>5</sup>.

Special architectural conditions and needs are common in almost all shopping centres. The main retrofit drivers are:

- (i) improve the indoor environmental quality and functionality, to enhance the customers' experience;
- (ii) reduce energy consumption;
- (iii) optimize the building operation and relative maintenance costs and
- (iv) improve the overall sustainability level reducing the environmental, social, and economic impact.

A shopping centre is a building, or a complex of buildings, designed and built to contain many interconnected activities in different areas. Shopping centres vary in their functions, typologies, forms and size, as well as the (shopping) trip purpose. Next to public spaces, there are areas related to workspaces, with different use and location and according to the shopping centre type. They have different opening hours and entrances than the shopping centre. Today, in addition to the mere commercial function, a shopping centre responds to several customer needs: it exhibits recreational attractions and modern amenities and is more commonly visited for eating-out motives than for buying daily needs. The retail tenant mix and atmosphere have the highest relative importance, together with convenience, refreshments and location. The majority of European shopping centres are already built, but there is still a huge potential for energy savings due to the practice of regular retrofitting and redesign. This state of constant change<sup>4</sup> offers regular opportunities to improve the technical systems, such as lighting, ventilation, the building envelope and monitoring systems, and more. Table 9 in Appendix provides a repository of possible solutions that were developed and tested in the EU project CommONEnergy [72].

The next subchapters provide a short description of the following technologies:

- Ventilative cooling
- Thermal zoning
- Concept of modular multifunctional facade
- Green vegetation
- Daylighting strategies
- ICT systems platform
- Interaction with local energy grid

### Ventilative cooling

The state-of-the-art of technologies available on the market and currently used in retail buildings highlighted several opportunities [72-74]:

- Airflow guiding ventilation components, such as automated windows and doors, are already integrated in most shopping centres but they are usually controlled for smoke ventilation only;
- Because of the big volumes involved, the lack of resistance and the potential for more relaxed ranges of interior condition respect to retail stores, atria or in general common areas within the

---

<sup>5</sup> The website <http://commonenergyproject.eu/> explains the project. Outcomes of the project are collected here: <http://commonenergyproject.eu/resources/deliverables.html>

shopping centre can work as an exhaust air zone, with air flow driven both by thermal buoyancy and by Venturi effect;

- Airflow enhancing components applications, such as wind catchers and exhaust chimneys, can be particularly effective to cool shops with high internal gains. However, few products are available on the market and most of the applications are tailor-made installations.

Therefore, when dealing with retrofitting solutions, the ventilative cooling solution feasibility depends on the shopping centre design and on its interaction with the outdoor ambient. Large shopping centres are based on a model of small individual stores connected by open “transitional” spaces. These transitional spaces represent a peculiar type of indoor environment that borrow characteristics from outdoor spaces and from traditional indoor environments, which has the potential for more relaxed ranges of interior conditions and consequent energy savings. We conducted field studies on three shopping centres to investigate customers’ thermal responses to different indoor environment temperature conditions [75]. A statistical analysis of the collected data revealed that the use of Fanger model to assess thermal comfort in transitional spaces leads to an overestimation of discomfort conditions [76]. During the summer period, costumers declared to be in comfort conditions up to measured operative temperatures of 28 °C. This observation has important implications on the control and regulation of air conditioning systems during the summer period. Furthermore, when the outdoor temperature is higher than indoor temperature, the difference between outdoor and indoor temperature has no impact on thermal comfort sensation vote trend.

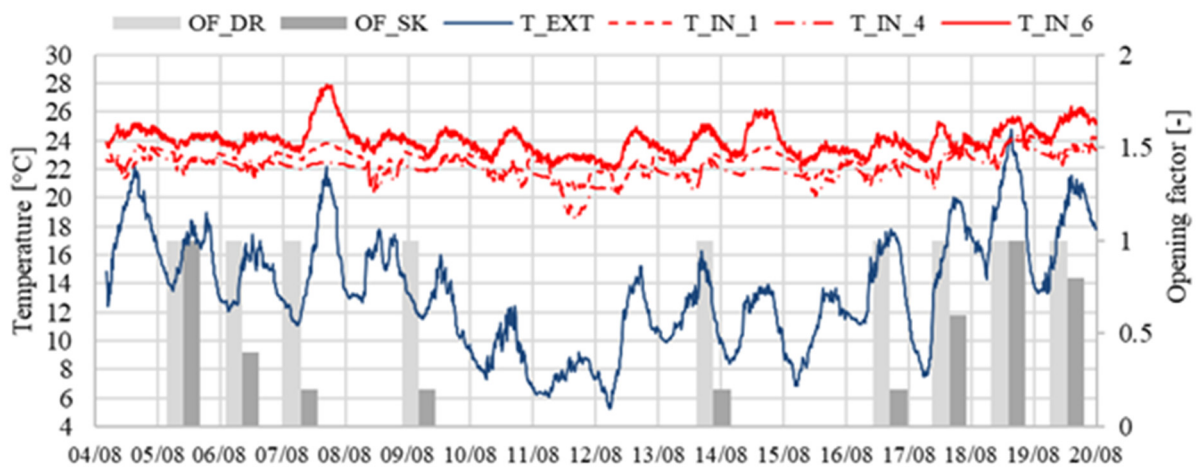

**Figure 29 Shopping centre, Trondheim, Norway. Monitored indoor and outdoor temperatures and opening factors from August 4<sup>th</sup> until August 20<sup>th</sup> 2016 [77].**

The proposed solution is active in the demo case since summer 2016. The graphs in Figure 29 report the monitored data recorded in August 2016 about outdoor ( $T_{EXT}$ ) and indoor ( $T_{IN}$ ) temperatures and doors and windows position ( $OF_{DR}$  = opening factor of doors,  $OF_{SK}$  = opening factor of skylight windows). The graph shows that, when natural ventilation is activated, indoor temperatures stay below 26°C. This demonstrates the suitability for the application of enhanced stack ventilation through the atrium. The natural ventilation strategy combines the effect of opened sliding doors and skylight openings to enhance stack ventilation and ventilate/cool the common areas. In order to prevent cold draughts, skylights windows groups are controlled separately, and the opening angle of the skylight windows is modulated according to the outdoor temperature and the indoor temperatures measured by sensors distributed within the common areas. Potential energy savings were estimated by building

energy simulations. The total electricity consumption for heating, cooling and ventilation of the common areas over the whole reference year is reduced by an 11% thanks to the exploitation of natural ventilation. Simulation results also showed that, with the control strategy defined, natural ventilation is effective in providing the minimum required air change rates for 98% of its activation time [77].

A retrofit package combining measures able to reduce internal and solar gains with measures enabling to effectively reject heat such as ventilative cooling strategies can potentially benefit from higher temperature set points leading to significant energy savings.

### Thermal zoning

Fluid dynamics interaction between refrigeration cabinets and Heating, Ventilation and Air-Conditioning (HVAC) delivery components has an influence on the energy performance of a food store. Refrigeration cabinets cool the environment where they are located as they extract heat from the store. On the other hand, cabinets' energy performance is influenced by environment temperature and humidity, air velocity (module and direction) and the presence of radiant surfaces. The recent trend in food stores is to adapt display cabinet closed by means of glass doors to reduce drastically energy consumption for refrigeration compared to open display cabinets [78, 79], as well as customers' comfort which is strongly influenced by the cabinets' cold surfaces. However, product visibility can be affected by mist formation on the glass. This effect takes place when the temperature at the external surface of the glass falls below the ambient dew temperature, which is a quite common situation in humid climate during the mid-season, when neither indoor air heating nor cooling is performed. Reduction or prevention of the risk of mist formation can be exploited by controlling relative humidity in the selling area or by increasing the external surface temperature at the glass doors. Control of relative humidity implies dehumidification and re-heating by the HVAC system, which is a very energy consuming operation. Heating glass doors require the use of electrical heaters whose energy consumption in the worst conditions can be even comparable to that of the refrigerating equipment. Adopting both strategies with an effective control can reduce the running costs but implies higher investment costs. In this context, the present deliverable proposes two enhanced concepts for thermal zones optimization within the food store and analyses their effect in terms of energy savings, thermal comfort and costs:

- The use of radiant panels as delivery devices in the refrigeration cabinets' zone;
- The use of specific air diffusers to prevent mist formation on cabinet doors.

Steady-state Computational Fluid Dynamics (CFD) simulation techniques have been employed to perform numerical solutions of air distribution for the proposed enhanced concepts [80]. Similar reference scenarios, representing common zone layouts in most food stores, have been defined in order to evaluate the interaction of display cabinets with the HVAC system and the risk of mist formation both in summer and winter conditions.

Analysis of refrigerated display cabinets' interaction with HVAC systems revealed that the installation of radiant ceiling in stores is considered to be more flexible than radiant floor at same heating efficiency and comfort levels. An additional option proposed is to position the radiant panels over display cabinets, ensuring higher flexibility and efficiency. Analysis of the risk of mist formation on closed display cabinets showed that up to 50% energy saving on electricity demand for demisting can be achieved combining a suitable distribution of the supplied air with a control system of electrical resistances able

to identify the beginning mist formation in an analogous way like in the operation control of radiant panels cooling rooms in summer period [80].

### **Concept of modular multifunctional façade**

Façade functions integration, able to support modularity, flexible to integrate a lot of energy-efficient strategies, adaptable to different climate conditions and indoor environment needs of the building to be retrofitted [81]. The façade system has a structural core that behaves similarly to a curtain wall but allows flexibility when incorporating strategies or technologies. The façade design concept aims at a modular structure, flexible enough to integrate any of the energy efficiency strategies, that adapt to the local climate and thermal needs of the building to be retrofitted. Targeted façade functions are, in order of priority:

- Protection against overheating
- Enhancement of natural ventilation
- Production of energy
- Transparency towards inside/from outside

The façade has a flexible light-weight frame structure which adapts to all building geometries. The frame system can also be configured in order to integrate different technologies such as different glazing systems, single or double skin façade, openable windows, greenery, shading systems, opaque elements, also including or Phase Change Materials (PCM) and photovoltaic modules.

### **Green vegetation**

The green vegetation impact onto shopping mall energy balance is investigated in the holistic framework of energy circulation between plant, sky and earth surface [82]. The heat island effect mitigation as climate protection issue and building envelope heat balance are distinguished and independently investigated. Features of both effects are described, and the last one is presented also through a mathematical model. The components related to greenery are discussed in detail. Particular attention is paid to the vegetated wall. The mathematical model is implemented into a standalone simulation tool for further parametric sensitivity analysis, including different climate, environmental and hardiness zones and different plants exploitation. The necessary data, which allow characterizing plants versus building energy balance is collected; the three most suitable climbing plants are proposed. Heat transport through a vegetated wall is simulated for different plants and different climate conditions. The shopping mall surroundings are being meanwhile analysed for possibly RES identification and exploitation. The flow driving components in the form of plants tunnel-like structure are investigated as a possible place for wind energy gathering. Results of analysis allowed to conclude, that the plants which are placed in the shopping centre environment have a minor impact when RES are considered. However, the ground surrounding of the shopping mall has an impact onto wall temperature – thus heat transport conditions through the wall. Finally:

- The green wall is recommended as a way to moderate outer temperature of the wall and estimated savings for heating/cooling of shopping mall per square meter of the vegetated wall are proposed.
- The green ground is recommended as a way to moderate outer temperature of the wall and estimated savings for heating/cooling of shopping mall per square meter of the vegetated wall are proposed.

The equivalent U was formulated for green wall and recommendations for greenery placing on the wall were formulated. For case studies, the demo sites in Valladolid and Genoa were considered. In line with

available data, the Valladolid demo site was proposed to integrate trees as a part of the market specification and Genoa demo site was proposed to integrate green sheds on the roof parking and to set up the green wall components on the NW building.

### **Daylighting strategies**

This work developed daylighting strategies for shopping centres with the target to maximise the space quality by harvesting the right amount of daylight with appropriate light distribution and achieve energy savings by an aligned artificial lighting concept. Due to very different existing buildings, different interior requirements and differing environmental climatic conditions, the strategies should be flexible in application and simultaneously easy to adapt to project specific requirements. 3 important building areas have been treated on the basis of our actual demo buildings:

- Typical zone in a historic market hall
- Gallery in a shopping centre
- Small shop in a shopping centre

### **Market hall**

For an efficient artificial lighting system LED as a light source and a luminaire with optimised optics were suggested. Daylight zones with daylight-sensitive control by dimming have to be defined, scenarios for stocking activities (no customers in the building) with reduced intensities could be implemented and automatic light level preservation control could provide a consistent light output over the lifetime while saving energy.

### **Gallery**

Existing atria in malls often do have severe problems with the quality of the indoor daylight situation. Daylight openings are often too large and are located disadvantageous. This results in high general indoor luminance values and excessive entry of direct sunlight. Besides glare issues, radiation loads on merchandise and heat gains, this situation leads to high artificial lighting intensities in the surrounding areas to match the daylight situation. The concept developed in CommONEnergy foresees implementation of a so-called “Modular Roof Skylight” which allows to combine different roof elements according to the actual project’s demand to achieve a good daylight impression in the atria, avoid direct sunlight on critical surfaces for a longer period and restrict the daylight factor to a maximum of 5% to 10% (resulting in maximum illuminance values of up to 1000 lux for an overcast sky in summer)(see Figure 30). Gloomy impression of adjacent areas - corridors or shops - is avoided and the intensity level of artificial light in adjacent areas can be reduced to a reasonable value [83].



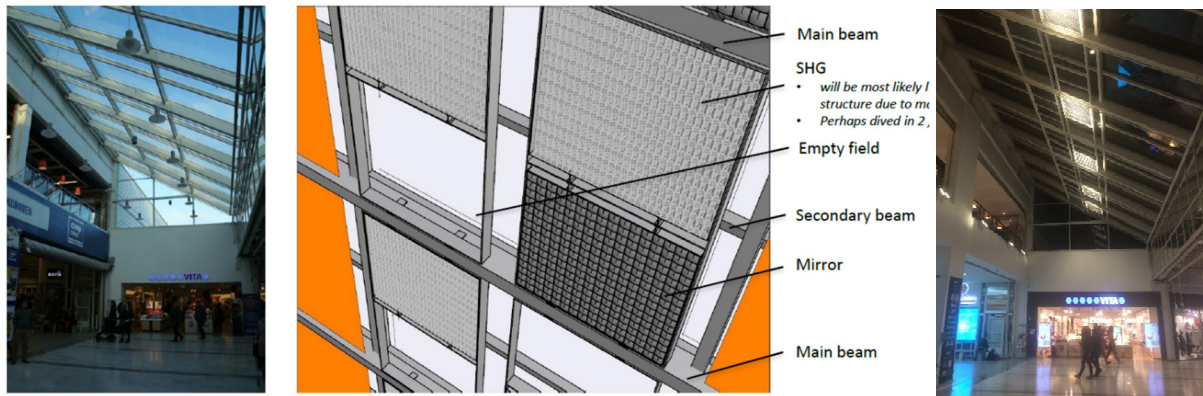

**Figure 30 Shopping centre, Trondheim, Norway. Modular skylight in atrium (left before; middle system sketch; right, after installation)** (Pictures: SINTEF)

### Shops

Shops often do not have daylight access at all, although studies revealed a positive impact on buying behaviour and well-being of occupants. There are plenty of reasons for this, first of all, disadvantageous geometry of the shopping centre typology, danger of destruction of merchandise or incompatibility with a sophisticated artificial lighting concept. In CommONEnergy we recommend adding daylight openings in shops during refurbishment accompanied by a careful planning process. Daylight intensity should be exactly controllable as well as a daylight-sensitive control adds precisely artificial light to reach the nominal target values [84, 85]. In the demo building in Trondheim, we implemented three light tubes as daylight systems. These cylindrical tubes transport light with highly reflective material from the roof (as the only room surface that has contact to outside) downwards to the sale area. System development optimized the coupling of light, exact dosage of induced daylight by an integrated screen and control strategy. An artificial lighting system based on LED was integrated into the light tube (Figure 31).



**Figure 31 Shopping centre, Trondheim, Norway. The artificial lighting system based on LED was integrated on the top of the light tube. Left: light tube from inside; right: light tube from outside** (Pictures: SINTEF)

### Prototypes of combined daylight system

In CommONEnergy project two daylight systems were developed and manufactured:

- Light pipe with shading screen and integrated artificial lighting system for application in a shop (see Figure 32).
- Solar harvesting grid (SHG) as part of the modular roof system for large glass-covered galleries.



**Figure 32** Shopping centre in Trondheim, Norway. Three light pipes have been mounted in one shop.

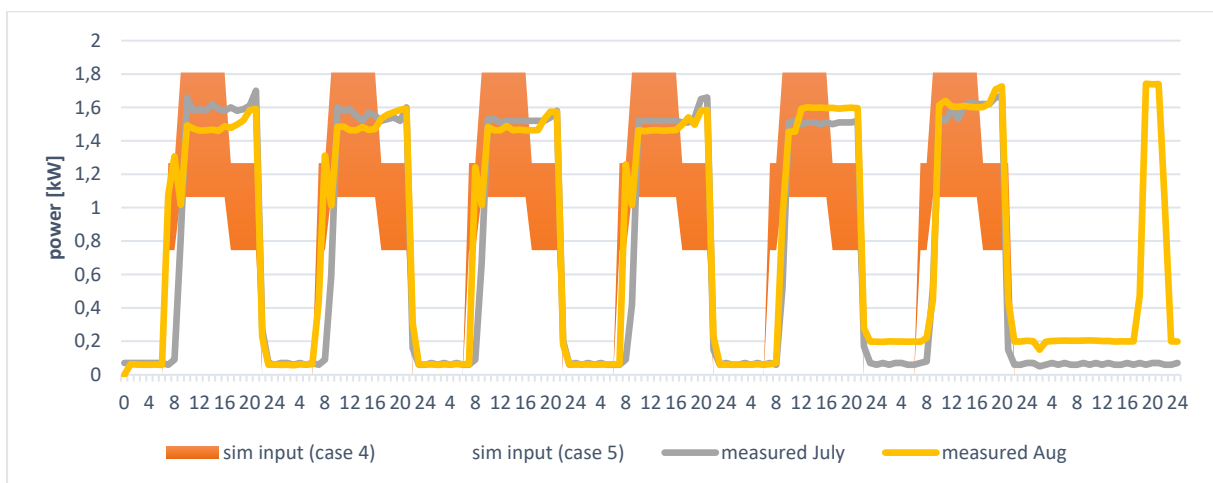

**Figure 33** Installation of light pipe in a shop in a shopping centre, Trondheim, Norway measured and simulated lighting power in one shop with light tubes [86].

In Figure 33 the measured and simulated power for lighting is shown. It can be seen that during opening hours the power for lighting is around 1.6 kW for the shop which corresponds well with simulated values [86].

**Table 7 Final energy use of lighting strategy in [kWh/(m<sup>2</sup>·yr)] for different cases [87].**

Case	area	Lighting	Heating	Cooling	Sum
(0)	-	137.3	49.5	20.1	206.8
(1)	cma	121.6	57.2	19.5	198.3
	cma+shp	109.3	58.2	16.2	183.7
(2)	cma	120.9	57.5	19.5	197.9
	cma+shp	80.1	59.9	7.0	147.0
(3)	cma	120.1	57.8	19.4	197.3
	cma+shp	55	67.5	4.0	126.5
(4)	cma	119.4	58.1	19.4	196.9
	cma+shp	50	70.4	4.0	124.4
(5)	shops on first floor	31.2	84.3	4.0	119.5

Table 7 shows the heating and cooling implications for the Trondheim demo case. It can be seen that cooling reduces from 20.1 kWh/(m<sup>2</sup>·yr) (case (0) to 4 kWh/(m<sup>2</sup>·yr)) for cases (4) and (5). The need for heating increases from 49.5 kWh/(m<sup>2</sup>·yr) (case (0)) to 70.4 kWh/(m<sup>2</sup>·yr) for case (4) and 84.3 kWh/(m<sup>2</sup>·yr) for case (5). Together with electricity reduction from lighting the sum also reduces from 206.8 kWh/(m<sup>2</sup>·yr) (case (0)) to 124.4 kWh/(m<sup>2</sup>·yr) for case (4) and 119.5 kWh/(m<sup>2</sup>·yr) for case (5). The changes are small when looking at the results for the common areas (cma). Energy use for cooling reduces insignificantly from 20.1 kWh/(m<sup>2</sup>·yr) (case (0) to 19.4 kWh/(m<sup>2</sup>·yr)) for cases (4). Energy use for heating increases from 49.5 kWh/(m<sup>2</sup>·yr) (case (0) to 58.1 kWh/(m<sup>2</sup>·yr)) for cases (4) [88].

### ICT systems platform

Contemporary shopping malls include various, sub-systems which when communicate with each other can perform more efficient compared to stand-alone systems. The work was focused on possible systems to be located in a shopping mall (ex. Art lights, daylight systems, HVAC & Refrigeration systems etc) [89]. For the intelligent BEMS to work properly it is required to exchange information with all the connected sub-systems. Through the advancement of communication technology, the use of ICT (information and communication technologies) for the communication between sub-systems in a shopping mall was developed. The communication properties of each sub-system are analytically identified from the involved partners and the plan for communication with the iBEMS has been organised. After having defined the technical fundamental requirements necessary to allow the deployment of the iBEMS, the work was focused on the design and development of the iBEMS interfaces:

- Machine to Machine (M2M)
- Human to Machine (H2M) or
- Graphics User Interface (GUI)

The former allows the integration of sensors, plants, and subsystems under the functional architecture studied. The latter opens the access to the iBEMS on the user side to the shopping mall owner, facility manager, building maintainer or other key-actors in the shopping mall management. A tool to get the needed information about energy consumption correlated and aggregated according to their needs has been developed specifically for shopping malls starting by basic functional blocks. M2M communication consists of taking data out of a machine so that it can be analyzed and sent over a network: the monitored machine may be as simple as a temperature sensor, level indicator or contact closure or a computer system such as SCADA, Programmable logic control (PLC), control unit, or even Building management system (BMS) or Building Automation System (BAS). The data transmission in M2M applications involves some security aspects such as authentication and access control that can be critical in a complex building such as a shopping mall, where tenants and gallery shops have typically limited access, while owners or facility managers have access to the general plants and systems.

An intelligent BEMS, integrated solutions that includes monitoring and the management of differing systems of the shopping centres, then from the main ones, like heating and lighting to other correlated services, has been installed in all the pilot systems, with different functionalities.

iBEMS forecasts the integration of sensors, systems and subsystems that are able to collect complete information and make it available to the proprietors of the shopping centres, to their management team and to all the participants involved in the construction, restructuring and maintenance of the malls.

Thanks to iBEMS, the different systems present in each centre, are put into communication with each other to improve the performance, while an ICT system facilitates the process and allows this interaction, in addition to the collecting of completed data. Additionally, respecting the requirements of EN15232, allows buildings to reach class A certification in the Building Automation Efficiency. The architecture proposed by iBEMS then, consists in centralizing and putting into communication all the systems and subsystems, in particular: lighting and management of natural light; heat and air-conditioning; solar panels; food refrigeration; hydrogen and electric batteries.

To these, we can add other active applications like the recharging of electric cars.

Moreover, all systems are connected to weather stations to always keep into account the conditions of temperature, humidity, and exterior lighting.

### **Interaction with local energy grid**

As a general conclusion and after studying the 10 reference shopping centres, we verified that there is a significant potential for improvement in the interaction between the building and the energy grid. It is noticeable the potential for integration of renewable energies such as solar (through PV) and wind (wind turbine), depending on the weather conditions, the availability of free spaces where it is possible to integrate the systems, but also without obstacles that could compromise the effective functioning [90-93]. Table 8 summarized the solutions proposed for each building reflecting the degree of improvement in the interaction between the shopping centres and the electrical grid with different colours. Then and depending on the degree of improvement, is going to be possible to extract a general idea of the most feasible solutions to be applied in a general shopping centre.

**Table 8 Load matching and grid interaction for European shopping centres, Load Match for the energy efficiency solutions (Lighting “LG”, Envelope “EN”, HVAC and Refrigeration “RF”) has been calculated taking into account the PV integration and then discounting it of the final value [94].**

Load

matchg.

SC1  
SC2  
SC3  
SC4  
SC5  
SC6  
SC7  
SC8  
SC9  
SC10

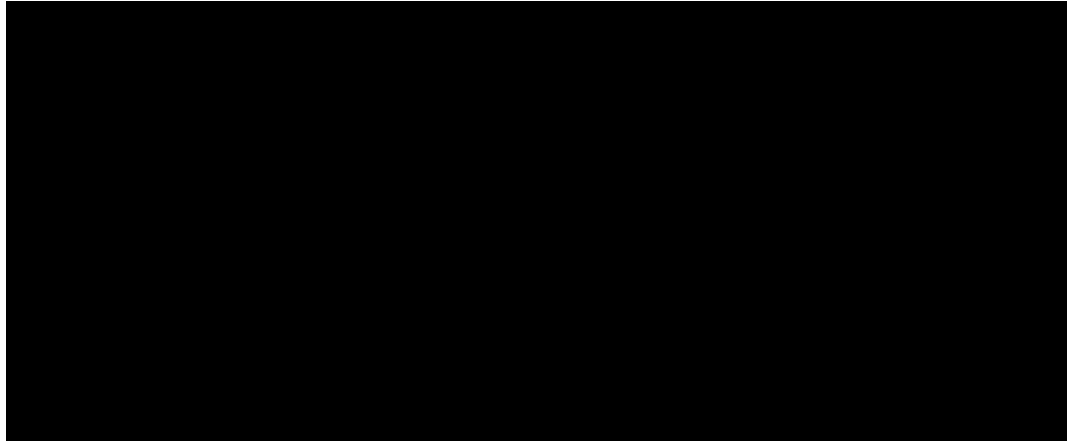

Grid

inter.

SC1  
SC2  
SC3  
SC4  
SC5  
SC6  
SC7  
SC8  
SC9  
SC10

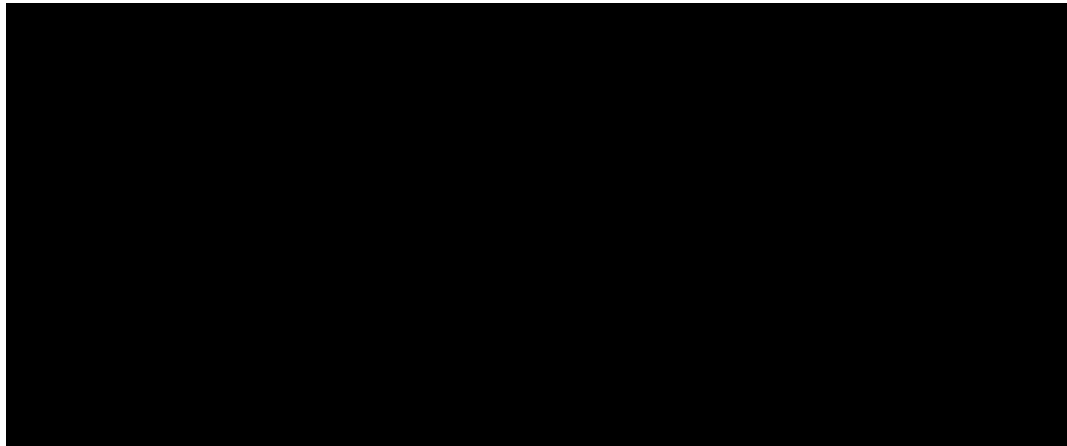

**Legend:**

Large improvement



Medium improvement



Low improvement



Not defined



With the integration of renewables and relative self-consumption is possible to reduce the electrical demand from the grid to which the shopping centre is connected. Cogeneration systems, are also very useful in terms of self-consumption and reduction of demand from the grid, producing at the same time electricity and thermal energy which also allow to decrease the overall primary energy. The replacement of old or bad sized lighting or HVAC systems has of course a great potential of reduction of electrical consumption and impact on the grid. This is also possible through the improvement of the envelope performance, and through suitable control and management systems, enabling to manage the demand optimizing the way in which the shopping centre consumes/distributes the electricity. Energy storage system allow to collect energy produced by renewables energies or when the grid is in valley period with low electricity demand and then use it or feed in the grid in peak periods.

The main potentials are in the old and inefficient systems which produce a high consumption of electricity, the absence of control and management systems and controllability of the demand able to adapt the consumption/production to each period of time, spaces free of obstacles and with suitable conditions both inside or outside the building that could be exploited integrating generation systems both RES and cogeneration, the possibility to exploit natural resources such as daylight instead of artificial light and natural ventilation instead of mechanical, and thermal fluxes not very well exploited. All these solutions, alone or in combination, allow to improve the interaction between the shopping centres and the electrical grid they are part of, either by reducing the electrical demand from the grid, or by providing service pouring electricity from them to the grid [94].

## Discussion

When assessing energy performance, comfort quality and economic feasibility of shopping centres retrofit or new design, a comprehensive approach is needed. Improvements on the equipment performance or reduction of the building loads, in fact, also influence other parts of the entire shopping centre system. In this sense, during the design process, these interactions cannot be neglected to avoid accounting twice for the same effect or disregarding other phenomena. In complex systems such as shopping centres, theoretical modelling and dynamic energy simulations can help assess energy efficiency improvement, system functionality and comfort quality of the overall building or of parts of it. With dynamic simulations, in fact, it is possible to account for the different parts that constitute a shopping centre such as the envelope and different use zones, natural and mechanical ventilation, lighting, refrigeration, Heating Ventilation and Air Conditioning (HVAC) systems as well as their interconnections. Moreover, once the model of the whole system is developed, the control strategies for managing the shopping centre can be implemented and tested. Numerical models and energy dynamic simulations can also have a role during the operational phase.

Metrics and tools are used in **Integrated Design Processes (IDP)** to select the best retrofitting actions [95, 96]. The IDP approach involves: as a first step, the analysis of the current building energy behaviour, the identification of inefficiencies and a proposal of solutions that could be suitable for each building; in a second phase, the assessment analysis of consumption for the living comfort and for other functions, with investment pay-back evaluations.

To manage the complexity of the shopping centre retrofitting design phase, it is important to work in an **Integrative Modelling Environment (IME)** including numerical models of all technology solutions used in shopping centres [97]. The IME simplifies the definition of an overall numerical model of the shopping centre to support the design-team decision-process (integrative design process); assessing the building behaviour and systems performance; analysing possible indoor comfort conditions; developing and testing a comprehensive set of control rules and finally defining cost-effective facility-management strategies [98-100].

To manage the complexity in the operational phase, a smart building management system is needed, specifically tailored for shopping centres, including functional concepts for infrastructural connection (energy grids, electrical mobility and energy storage systems). Continuous commissioning supports the performance assessment (comfort, energy, economics) in the operational phase, enabling the characterisation of shopping centres in a synthetic way.

Finally, in a retrofitting process, it is important to consider the environmental and social impact to satisfy both the need of developers for third-party certification of the building quality and the life cycle sustainability of the investment in retrofitting, including benefits for all stakeholders, from owners to community.

### **Conclusions and need for further work**

Future developments in the field of shopping centres retrofitting require considering energy efficiency and architectural qualities at the same time. Buildings should be adaptable and spaces flexible both in terms of usage and energy uses. Functionality and technology, however, should not be allowed to dominate at the cost of aesthetic and architectural quality. One of the CommONEnergy project survey suggests that the sustainable shopping centres of the future will have high architectural quality while focusing on legibility, durability and energy use. Considering a shopping centre as an energy system the focus will be even more on integration, from both technology and control strategy points of view, and including the exploitation of local climate conditions, and synergies with the urban contexts and energy grids. A parametric definition of the component features and the further development of a modular structure of the model layout eases the development of a shopping centre system model, allows the optimization of the components size and the simulation of different scenarios and solution-sets, facilitates sensitivity analysis, uncertainty analysis, multi-objective optimization and model calibration.

Besides technologies and methodologies, the project developed policy recommendations grouped under four main themes:

- Engaging stakeholders,
- Communicating the benefits of retrofitting,
- Promoting energy efficient technology packages, and
- Supporting the energy transition.

Building on the project's demo cases, and giving concrete examples of the benefits coming from the retrofitting of shopping centres, the recommendations presented in the policy paper can serve as an important basis for catching the opportunity of a more ambitious revision of the EPBD and a better recognition of the strong role shopping centres can play in achieving the EU energy efficiency targets . In relation to each specific technology developed in CommONEnergy project, the following recommendations for further work can be suggested.

#### *Ventilative cooling*

- provide guidelines for the proper design and control of hybrid ventilation systems, in order to exploit natural driving forces (wind and stack effect);
- provide tools to enable the simple and consistent evaluation of the performance of automated ventilative cooling systems in standards and regulation, such as the adoption of methods of calculation allowing taking into account dynamic aspects and the adoption of standards to evaluate performance after installation;
- define common standard requirements for anti-intrusion measures, such as burglary and insect-proof devices.

#### *Thermal zoning optimization*

- revise the standards addressing thermal comfort by rethinking the notion in a broader and more holistic way, i.e. taking into account dynamic, integrated, and participatory aspects, in order to avoid the potential occurrence of spot conflicts with the standard prescriptions.



*Modular multi-functional climate-adaptive façade*

- develop a specific measurement and verification protocol for adaptive facades;
- adopt methods of calculation allowing taking into account dynamic aspects;
- find more suitable performance indicators for dynamic building envelopes.

*Green integration*

- implement specific building code guidelines and requirements related to green roofs and walls
- implement building permit regulations where green envelope can contribute to enhance the bioactive area rate of building land
- support a balanced sharing of costs and benefits between owners and tenants, in order to respond to higher maintenance costs of vegetated roofs and façades, e.g. through the establishment of Green Leases

*Daylight strategies*

- adopt explicit requirements for daylight in shopping malls
- introduce parameters to evaluate not only energy saving but also improvements in quality change (e.g.: comfort).

*Artificial lighting*

- introduce parameters to evaluate not only energy saving but also improvements in quality change (e.g. comfort), in coherence with the recommendation proposed for daylight strategies.

*Intelligent BEMS*

- introduce minimum performance requirements for active control systems for shopping malls (EN 15232 standard classification).

*Smart integration in energy grid*

- encourage practices aimed to make on-site renewable generation accessible to a larger number of users, such as joint purchasing programs or leasing models involving third parties guarantee;
- develop strategies to anticipate, integrate, and plan for a growing number of commercial prosumers, e.g. including new market structures for excess generation (where this occurs), as well as new regulations governing grid access and network charges. On one side, for countries where commercial retail prices of energy are high, remuneration of electricity injections could be below the full retail rate, and would therefore differ from traditional net metering, in order to avoid excess compensation and encourage efficient use. On the other side, for countries where commercial retail rates for energy are low, rates offered for electricity fed into the grid should be planned as slight premium to the commercial retail rate paid, in order to drive adoption;
- encourage the installation of smart meters in order to facilitate understanding and possible choice of different electricity market options;
- encourage demand side flexibility, promoting demand response and distributed energy storage.

*Energy storage*

identify specific remuneration schemes for the provision of ancillary services, such as capacity-based remuneration. If storage systems can also be functional to the network, for example for the primary reserve service that they can provide, the service shall be recognized and remunerated at the right price, defined under market conditions.

**Table 9 Repository of technologies developed within the EU FP7 CommONEnergy project [72].**

Technology	List	Brief description	Application	Expected energy savings
Ventilative cooling	Enhanced stack ventilation	automated openings located in the skylights to enhance stack ventilation	common areas with skylights and openable parts at lower levels	cooling need reduction, energy consumption for ventilation reduction
	Windcatcher	windcatcher integrated into light tubes to naturally ventilate shops	Shops on the last floor with no parking on the roof	cooling need reduction, energy consumption for ventilation reduction
	single-sided ventilation	automated openings located in the facade to exploit natural ventilation	common areas/shops with external facade	cooling need reduction, energy consumption for ventilation reduction
	Fan assisted ventilation	increased mechanical ventilation rates to reduce the cooling need	common areas/shops/food store	cooling need reduction
Thermal zoning optimization	radiant panels	air conditioning in the refrigeration cabinets zones by means of radiant panels	Supermarkets with closed refrigeration cabinets	energy needs reduction and improved comfort
	full air with air supply diffusers for anti-mist formation	use of specific air diffusers to prevent mist formation on cabinet doors supported by a control system for the activation of electric resistances.	Supermarkets with closed refrigeration cabinets	demisting energy reduction
Modular multifunctional climate adaptive facade	configuration 1	bottom and top openings with integrated PV in the bottom part and shading system	shops, supermarket, food court in cold/mild climates with envelope airtightness constraints	cooling & heating need reduction, energy consumption for ventilation reduction, PV is providing electricity for automation
	configuration 2	ventilator louvres with integrated PV and shading	atrium, transitional spaces in warm climates with no air tightness constraints	cooling & heating need reduction, energy consumption for ventilation reduction, PV is providing electricity for automation
Green integration	surrounding trees, bush, pavement/lawn proportion intensive/active vegetated roof	change microclimate characteristics (temperature, humidity, oxygenation etc) in building's surroundings up to 1000m extends bigger plants, higher initial and exploitation costs, weight- up to 1300kg/m <sup>2</sup> , soil substratum thickness min. 30 cm; change microclimate, improves building heat balance	building's exterior unbuilt areas like parking areas, lawns etc. common areas/ common green spaces	cooling need reduction cooling & heating need reduction
	extensive/passive vegetated roof	smaller plants, lower costs, weight 50-300kg/m <sup>2</sup> , climbing plants rooted in the ground directly or in pots, change microclimate, improve rainwater management, improves building heat balance	horizontal shading systems e.g. parking sheds	cooling need reduction
	direct vegetated wall	the greening system uses the facade as a growing guide; improves rainwater management, change microclimate, improves building heat balance	East, South and west oriented exterior facades	cooling & heating need reduction
	indirect vegetated wall	the greening system and the facade are separated with an air cavity; improves rainwater management, change microclimate, improves building heat balance	East, South and west oriented exterior facades	cooling & heating need reduction
Smart coatings	IR-reflective/absorbing	All possible combinations from these characteristics may be selected.	All substrates of roof or façade, that could be painted	Cooling or heating need reduction less maintenance

Technology	List	Brief description	Application	Expected energy savings
	self-cleaning insulating anti-mold		with a conventional paint	
Daylight strategies	external solar lamellas	Static opaque lamella, adjustable to climate and indoor requirements by different lamella distances	in front of vertical glass areas of common mall area, also restaurants,...	Savings in cooling energy, simultaneously reasonable energy demand for artificial light
	modular roof, Solar harvesting grid	Grid structure which harvests direct sun while redirecting in uncritical directions (avoiding glare), is part of an overall concept, called modular roof, which can react to project-specific conditions (e.g. the position of sale area, climate,...)	Main Atria in common mall area	Direct sun might be used for heating in winter or cold regions while not blocking direct sun, but redirecting the sun. Modular roof concept allows to exactly engineer the roof regarding its lighting demand and passive heat gains
	light-tube	Daylight system which guides daylight from the roof into the room by excellent light transmission properties, improvement in visual comfort and benefits for higher turnover	Shops, Common mall area	Savings by reduced use of artificial light
iBEMS (intelligent Building Energy Management System)	HVAC + shading + artificial lights + natural ventilation + energy and environmental condition monitoring + refrigeration system	The iBEMS provides the required communication means between the installed systems and respective sensors. It incorporates control rules (higher and lower level) for the optimization of the system. In parallel measure the energy consumption of the connected systems in order to calculate their efficiency.	All areas of demo case and reference buildings	The iBEMS maximise the energy saving by monitoring the performance and consumption of all the subsystems connected while guarantying their efficiency.  The expected energy savings is related to the managed systems
Electrical Energy storage	PV + battery	use of PV+battery storage to increase self-consumption for the all shopping mall consumption or to cover dedicated load or EV-charger	PV on the roof of shopping mall or parking area on platform roof. Suitable area for battery (space, ventilation, temperature)	increase of energy self-produced and self-consumed
	PV + H2	H2 for hydrogen car mobility or with FC for electricity consumption	Suitable area for H2 (space, ventilation, temperature, security issues)	possibility to offer H2 gas station for car using PV generated power
	PV + Storage + electromobility	Use the storage for Ev-charger	possible station in shopping mall parking area (open or close)	possibility to offer recharge for e-cars using PV generated power
Refrigeration system	Transcritical system for warm climate	Transcritical system with features able to manage high external temperature in an efficient way	Warm climates	No significant energy savings but lower environmental impact due to the use of a natural refrigerant instead of a synthetic one
	Transcritical system with HVAC Integration	The refrigeration system actively recover the waste heat of the condensing side to satisfy heating and cooling demand	Small supermarkets in warm climates	Enhance the overall efficiency recovering the waste heat from the refrigeration
	Transcritical system with	Solar and refrigeration system work together to maximize the heat production and running the	Supermarkets in warm climates	Integration with solar technology, reducing pay-back time

Technology	List	Brief description	Application	Expected energy savings
	Solar Integration	adsorption machine in stable condition. Exceeding solar thermal power is used by refrigeration to sub-cool itself.		
	Transcritical heat pump for Heating and/or Domestic Hot Water (DHW)	Heat pump with natural refrigerant producing heat and DHW	Supermarkets	Natural solution for heating and DHW system
	Thermal storage to manage refrigeration load peak	Fire-prevention tanks used to shave cooling peak request. Inertia principle.	Shopping malls with area fire-prevention tanks	Thermal peak-shave
	Integral refrigeration based on water loop within the refrigeration system	Integral cabinet with water condensed system and a water loop able to remove the heat outside the store.	Supermarkets	Easy split of the energy consumption between final users. Limit refrigerant charge. Independent behaviour of each cooling device maximizing efficiency in the presence of different type of load
	HVAC&R water loop distribution inside the building	Water loop system linked with w/a heat pump, balanced to maintain stable temperature during the year	Supermarkets	Easy split of the energy consumption between final users. Limit refrigerant charge. Independent behaviour of each cooling device.
Artificial lighting systems	General Retail Lighting (GRL)	Energy-efficient light source: LED, precise distribution by 7 downlights, backlit area to prevent glare, 3 light colours, constant light output control	Common mall area, main traffic zones in larger shops	dependent on technologies which are replaced, dependent on iBEMS features (like schedules for light colors or cleaning)
	projector/mirror system	Energy-efficient light source: LED, improved maintenance (longer lifetime, luminaires easier accessible), pleasant "architectural" light, glass roof will be visually closed at night by mirror	Main atria in common mall area	dependent on technologies which are replaced
	LED wall washer	Energy-efficient light source: LED, precise illumination for merchandise arranged at wall, longitudinal glare protection	In Shops, merchandise arranged at walls	dependent on technologies which are replaced, dependent on iBEMS features (like schedules for light colors or cleaning)
	Integration of LED artificial light in the light tube	Supplements artificial light to daylight via 24 micro LED luminaires at the upper rim of the light tube, uses the distribution body of the light tube	Shops, Common mall area	Energy-efficient daylight dependent control
	Green lighting box	Turn-key ready control solution for shops that implements high-quality lighting scenes for retail applications, energy-saving strategies and monitoring possibilities	Device (control unit, shop control panel, DALI gateways) that can be installed quickly in shops, connection to central iBEMS possible	Key instrument (algorithm plus device) to control energy-efficient lighting scenes, e.g. schedules, daylight-dependent control of artificial light etc.
Building Integrated Electric Mobility system	Charging stations	The Electric Vehicle (EV) Charging station provides a refuelling point for electric vehicles. Required power can be provided from either the grid or a storage system	Parking area The number of plugs and the power is related to the diffusion of the BEV (battery electric	The savings depends on the number of cars charged and on the type of energy used (e.g. renewable energy).

Technology	List	Brief description	Application	Expected energy savings
		(hydrogen or Chemical). The electric vehicles can be of customers or mall employees	vehicle). The diffusion is driven mainly by the national incentives	Due to the BiEM is possible to manage the flux of power in order to maximise the usage of RES.
	Electrolyser and storage	The hydrogen storage system transforms available power to gas and stores it for future use. The opposite transformation provides base power for charging electric vehicles.	Parking area with a natural gas grid connection for store hydrogen.	The energy saving is related to the type of energy used in the electrolyser.
	Hydrogen mobility	Parallel to the previous description, the stored Hydrogen can be used to refuel Hydrogen cars, which can belong to customers or mall employees.	Parking area in countries where there is a hypothesis of hydrogen mobility diffusion.	The energy saving is related to the type of energy used in the electrolyser.
	Battery for industrial vehicles	The chemical storage system using batteries is applied for storing excess energy from renewable energy systems or low-cost energy from the grid. When required the energy is transferred back to the grid or to Electric Vehicles.	Parking area	



**VISION:**

**«Sustainable  
neighbourhoods  
with zero  
greenhouse gas  
emissions»**

# Z E N

Research Centre on  
ZERO EMISSION  
NEIGHBOURHOODS  
IN SMART CITIES



<https://fmezen.no>