

# FME HighEFF

## Centre for an Energy Efficient and Competitive Industry for the Future



### Deliverable D3.1\_2017.01

#### Technologies for medium-temperature heat-to-power conversion

Delivery date: 2017-12-08

Organisation name of lead beneficiary for this deliverable:

**SINTEF Energy Research**

HighEFF- Centre for an Energy Efficient and Competitive Industry for the Future is one of Norway's Centre for Environment-friendly Energy Research (FME).  
Project co-funded by the Research Council of Norway and Industry partners.  
Host institution is SINTEF Energi AS.

#### Dissemination Level

PU	Public	X
RE	Restricted to a group specified by the consortium	

<b>Deliverable number:</b>	D3.1_2017.01
<b>ISBN number:</b>	
<b>Deliverable title:</b>	Technologies for medium-temperature heat-to-power conversion
<b>Work package:</b>	3.1
<b>Deliverable type:</b>	Memo
<b>Lead participant:</b>	SINTEF Energy Research

<b>Quality Assurance, status of deliverable</b>		
Action	Performed by	Date
Verified (WP leader)	Trond Andresen	2017-11-28
Reviewed (RA leader)	Trond Andresen	2017-11-28
Approved (dependent on nature of deliverable)*)	Trond Andresen/Petter Nekså	2017-12-08

\**) The quality assurance and approval of HighEFF deliverables and publications have to follow the established procedure. The procedure can be found in the HighEFF eRoom in the folder "Administrative > Procedures".*

<b>Authors</b>		
Author(s) Name	Organisation	E-mail address
Monika Nikolaisen	SINTEF Energy Research	Monika.Nikolaisen@sintef.no

<b>Abstract</b>
<p>This memo explores the potential and feasibility of different heat-to-power technologies for application in industrial surplus heat recovery. Several technologies are described and evaluated qualitatively for typical low-to-medium temperature heat sources in HighEFF partner industries. The evaluations are based on published literature as well as research experience at SINTEF Energy Research. RC-based technologies and absorption cycles were found to have most potential, whereas conventional and novel technologies such as the Stirling engine and PCM technology were found to be less promising. Literature indicates that total system size and heat source temperature are critical to thermodynamic performance, and should be considered in fair comparison between technologies. This memo serves as basis for future activities in WP3.1 Energy-to-power conversion, including a quantitative evaluation of promising technologies.</p>

# Table of Contents

1	Introduction.....	4
1.1	Background for heat-to-power conversion in HighEFF .....	4
1.2	Evaluating heat-to-power technologies in a HighEFF context .....	5
1.2.1	Relevant low-to-medium temperature heat sources in HighEFF partner industries .....	5
1.2.2	Evaluating heat-to-power technologies with the concept of exergy .....	5
2	Technologies for heat-to-power conversion .....	7
2.1	Steam Rankine cycle .....	7
2.2	Rankine cycle with other working fluids.....	8
2.2.1	Basic Rankine cycle .....	8
2.2.2	Recuperated Rankine cycle.....	9
2.2.3	Transcritical Rankine cycle.....	10
2.2.4	Trilateral flash cycle .....	11
2.2.5	Partially evaporating cycle.....	11
2.2.6	Flash cycle .....	12
2.2.7	Dual pressure cycle .....	13
2.2.8	RC with zeotropic mixtures as working fluid .....	14
2.2.9	Other Rankine cycle architectures.....	15
2.3	Absorption cycles.....	17
2.3.1	Kalina cycle .....	18
2.3.2	Salt-water absorption cycle .....	19
2.3.3	Carbon carrier cycle .....	19
2.4	Stirling engine .....	20
2.5	Thermoelectric generator.....	20
2.6	Membrane technology .....	21
2.7	PCM technology.....	21
3	Evaluation and summary .....	22
4	Conclusions and future work.....	25
	References .....	26
Appendix A	Framework for evaluating heat-to-power technologies .....	28

## 1 Introduction

### 1.1 Background for heat-to-power conversion in HighEFF

This aim of this memo is to explore the potential and feasibility of different heat-to-power technologies for low-to-medium temperature surplus heat (i.e. heat source temperatures below 300°C). Figure 1 illustrates three possible ways of re-utilizing recovered surplus heat, where direct use of the recovered energy as heat gives the highest rate of recovered-to-reutilized energy, followed by heat upgrade (e.g. use of a heat pump). The potential maximum levels of yield rate are directly connected to the thermodynamic concept of exergy, a term which describes the quality of energy in thermodynamic systems. Electric power is considered 100 % exergy, while thermal energy at e.g. 300 °C only contains ~50% exergy. Therefore, the lowest yield rate comes from conversion of heat to electric power because only the exergy will be re-utilized in this case. The concept of exergy is explained in more detailed in the HighEFF deliverable D4.2\_2017.04, called "Thermodynamics of surplus heat-to-power conversion, for dummies".

From a thermodynamic perspective, direct use or heat upgrade should be used over heat-to-power conversion whenever there is a practical use for the recovered energy as heat. However, for industries with large amounts of surplus heat or where reuse of heat is not needed in sufficiently significant amounts nearby, heat-to-power conversion becomes an interesting option. This is a typical situation in most Norwegian power-intensive industries, particularly oil and gas and metal industry, but also within the food and chemical sectors. The existence of substantial amounts of low-to-medium temperature surplus heat in these industries is both the reason and the primary target for the efforts on heat-to-power conversion in HighEFF.

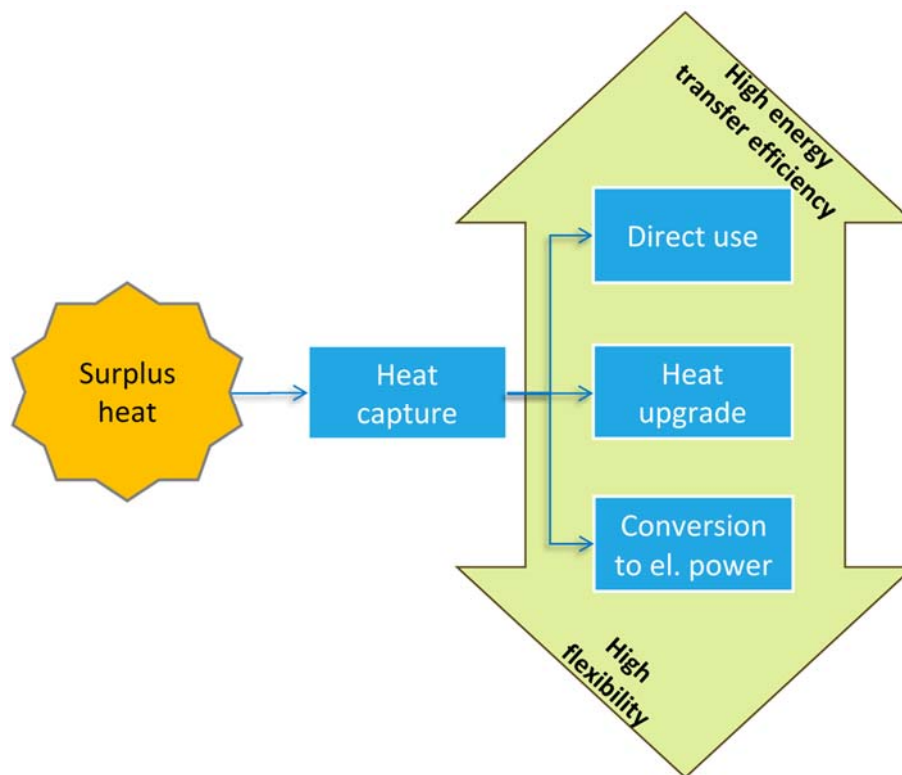

Figure 1 Surplus heat utilization

## 1.2 Evaluating heat-to-power technologies in a HighEFF context

Heat-to-power technologies will be evaluated for relevant heat sources in HighEFF partner industries, with the primary goal that technologies shall contribute to significant impact for targeted industry processes. The evaluation is based on initial investigation into the field of heat-to-power technologies, and considers published literature and research experience at SINTEF Energy Research. It is purely qualitative and will serve as basis for a more comprehensive, quantitative evaluation in 2018.

Figure 2 shows the main stages that will be performed in evaluation of heat-to-power technologies for the industry in HighEFF. Stage 1 and Stage 2 are covered in this memo, and Stage 2 and 3 will continue in 2018. Results of Stage 1 and 2 technology evaluations are given Table 1.

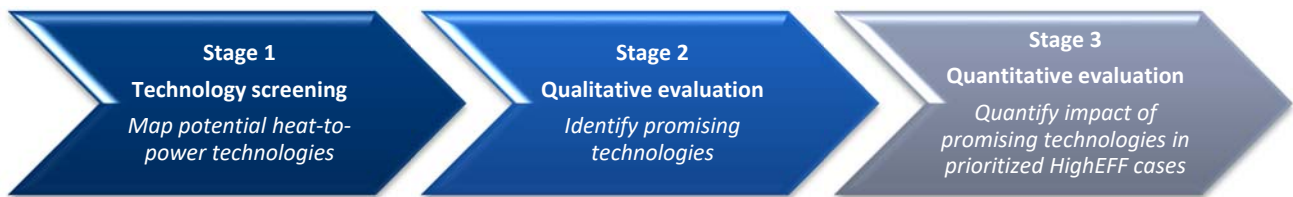

Figure 2 The main stages in evaluation of heat-to-power technologies for the industry in HighEFF

### 1.2.1 Relevant low-to-medium temperature heat sources in HighEFF partner industries

Heat-to-power technologies described in this memo will be evaluated based on their potential to utilize heat from relevant heat sources in HighEFF. The memo targets low-to-medium temperature heat sources specifically, but high temperature heat sources ( $> 300^{\circ}\text{C}$ ) are also relevant in HighEFF, and will be explored in future work. Relevant low-to-medium temperature heat sources are characterized by the following:

- Heat source temperature is in the "low-to-medium" range, i.e. below  $300^{\circ}\text{C}$
- Heat sources are *sensible*, i.e. heat source temperature is reduced as heat is extracted
- Energy content in the heat source is significant
- Lower limit on heat source outlet temperature is common in several applications

### 1.2.2 Evaluating heat-to-power technologies with the concept of exergy

The concept of exergy is central in evaluation of technology performance, and refers to the maximum potential work output that can be produced from a process operating between a heat source and heat sink. *Exergy losses* reduce the potential power output from a process, and are present in any heat-to-power technology. However, some technologies can better utilize the potential work that exists between a heat source and heat sink, and will achieve a higher exergy efficiency (fraction of net power produced to the available exergy in the heat source).

It is desirable to identify the highest performing technologies in terms of exergy efficiency. An indication of exergy efficiency is how well the process is adapted to the temperature level and characteristics of the heat source and heat sink, and an important concept in this respect is "temperature matching". A good temperature match refers a close approach between the working fluid temperature and the heat source or heat sink temperature in the heat exchangers, and will contribute to low heat exchanger exergy losses. Other important parameters in technology evaluation include maturity level and process simplicity, and are also considered. Some general considerations and rules that shall apply in all technology evaluations and case studies involving surplus heat-to-power technologies are given in Appendix A

**Table 1 Evaluation of technologies for heat-to-power conversion from heat sources in temp. range 150-200 °C**

Group	Technology	Maturity	Simplicity	Performance	Technology description and evaluation basis
<b>Classic technologies</b>	Steam Rankine cycle				Conventional technology for high temperature heat-to-power conversion. Power is produced by expanding pressurized water through an expander. Not mature and has low performance in relevant temperature range.
	Stirling engine				Cyclical expansion and compression of gas drives rotation of a flywheel. High efficiency for small scale plants, but has scale up challenges and is poorly suited for sensible cooling. Not mature and has low efficiency in large scale waste heat recovery.
<b>RC family</b>	Basic RC				Operating principles similar to the steam cycle, but working fluids are adapted for low-to-medium temperature heat recovery. Thermodynamic potential limited by low heat source temperatures. Simple system and mature for low-to-medium temperature heat sources.
	RC with mixture as working fluid				Pure working fluid in RC replaced with zeotropic working fluid mixture. Temperature match in evaporator and condenser improved. Does not add system complexity, but affects heat transfer. Maturity low due to absence of experiments and demonstration plants.
	Transcritical RC				RC with evaporation pressure above critical pressure, which improves temperature match with heat source. Simple system, only difference from basic RC is that evaporator is replaced with heater. Medium performance, as demonstrations plants have shown promising results.
	Trilateral flash cycle, TFC				Fluid expands from liquid into two-phase region, which requires two-phase expander and improves temperature match in heater. Two-phase expanders have low maturity and increase process complexity. Medium performance due to low expander efficiency and high pumping power.
	Partially evaporating cycle, PEC				Similar to TFC, but allows partial evaporation of working fluid. Reduces pumping power and size of heater compared to equivalent TFC, but also gives poorer temperature match in heater. Maturity, simplicity and performance similar to TFC.
	Flash cycle, FC				Similar to TFC, but separation of liquid and vapor prior to expansion eliminates two-phase expansion. Introduces additional throttling losses, and reduces mass flow through expander. More complex system than the TFC, but higher maturity as two-phase expander is not required.
	Dual pressure cycle				Evaporation of working fluid at two pressure levels. Heat recovery from heat source improves, resulting in improved performance compared to basic RC. Mature in geothermal sector, not implemented in industrial waste heat recovery. Complex system with multiple components.
	Absorption cycles				Kalina cycle, CCC and salt-water absorption cycle. Evaporator of RC replaced with desorber, and/or condenser replaced with absorber. Thermodynamic performance improves, relatively complex system. Kalina cycle is commercialized, but the other cycles have low maturity.
<b>Other technologies</b>	TEG				Produces electricity directly from heat with semiconductors that conduct electricity when exposed to temperature difference. Concepts utilizing larger, finite heat sources not demonstrated, but possible option where conventional cycles are difficult to implement. Relatively low efficiency
	Membrane technology				Developed for desalination of water, but also produces high pressure steam that is expanded through a turbine to produce power. Could be suitable for regions with lacking drinking water and electricity infrastructure. Not developed for industrial scale heat. Relatively complex.
	PCM technology				Cyclical expansion and contraction of phase change material realises production of mechanical work. Currently in early stages of development, but plans exist to develop a 1 MW system. A relatively low efficiency of 7.5 % has been demonstrated.

## 2 Technologies for heat-to-power conversion

### 2.1 Steam Rankine cycle

The Steam Rankine cycle is perhaps the most well-known of all heat engines, having driven the industrial revolution and is still the most used cycle to produce electricity in the world, for example from fossil and nuclear fuels. The Steam Rankine cycle is a closed thermodynamic cycle for conversion of heat to power, and is built up of the four main process components sketched in Figure 3. The process is also drawn in a temperature-entropy diagram, which shows the change in states of the working fluid during an ideal process. Power is generated by transferring heat from a heat source to high pressure water that then boils into steam in an evaporator/boiler (2-3), and expanding the steam through an expander (3-4). The expander is connected to an electric generator that converts mechanical energy into electricity. After the expansion process, energy is still present in the steam in the form of low grade heat, which is rejected to a heat sink in a condenser (4-1). The water is then pumped back to high pressure (1-2), and into the boiler once again.

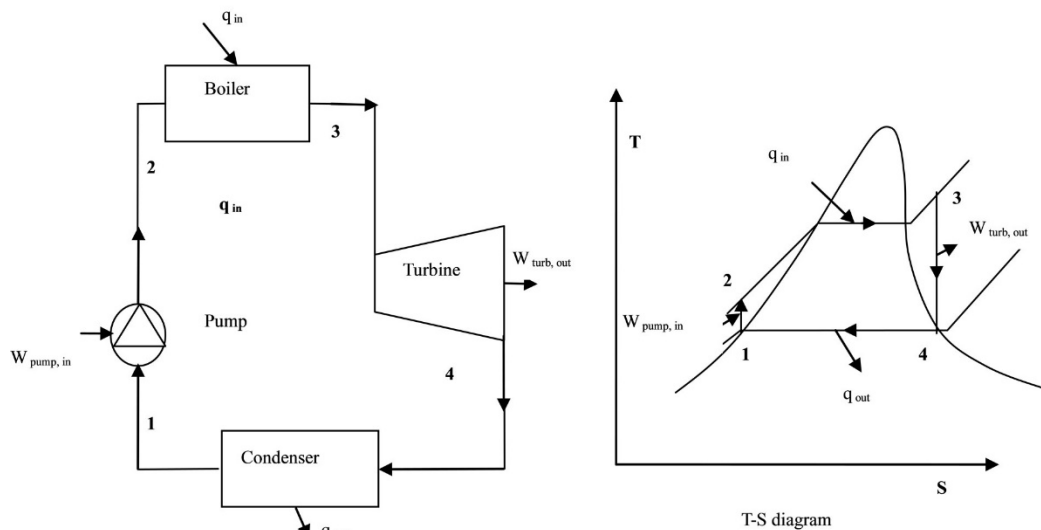

**Figure 3 Principle sketch of a Steam Rankine cycle [1]**

Due to the properties of water, the Steam Rankine cycle is suited for heat source temperatures above 450°C [2]. Water is the primary choice of working fluid for several reasons, including low flammability, GWP and price, as well as high chemical stability. Several properties make water unsuitable for low-to-medium temperature heat recovery. For instance, water is a "wet" fluid, meaning that the slope of its dew point curve in a temperature-entropy diagram is negative, as seen in Figure 4. As a result, superheating is required to avoid expansion in the two-phase region, which significantly reduces cycle efficiency in low-to-medium temperature heat recovery. Furthermore, steam cycles typically require some additional auxiliary systems such as makeup water and maintenance requirements are high. This makes the steam cycle unsuited for low capacity plants (typically lower than a few MW of electric output) [2] and un-manned operation. Another challenge with steam is sub-atmospheric condensation pressures.

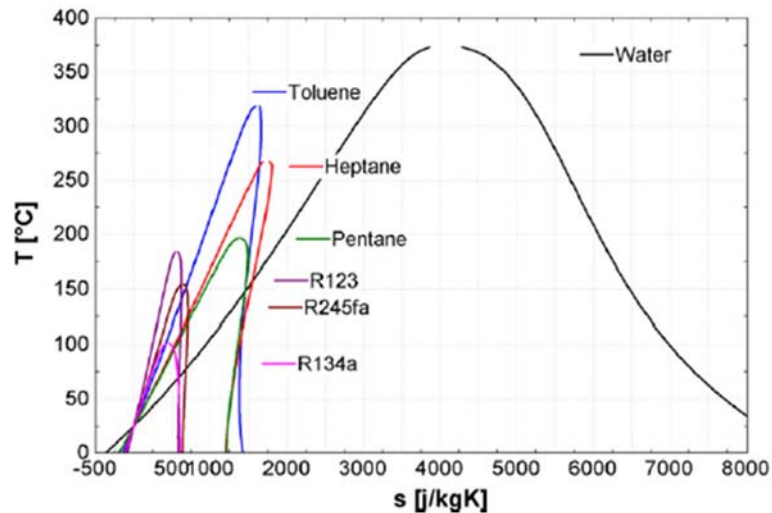

Figure 4 Principle temperature-entropy diagram of water (steam) and a selection of other fluids [2]

Several cycle modifications can be implemented to increase the performance of Steam Rankine cycles. A common modification is illustrated in Figure 5, where the working fluid is reheated by the evaporator (2-2') between two expansion stages such two-phase expansion is avoided. Reheat can be used to increase the average temperature of heat addition and improve cycle efficiency.

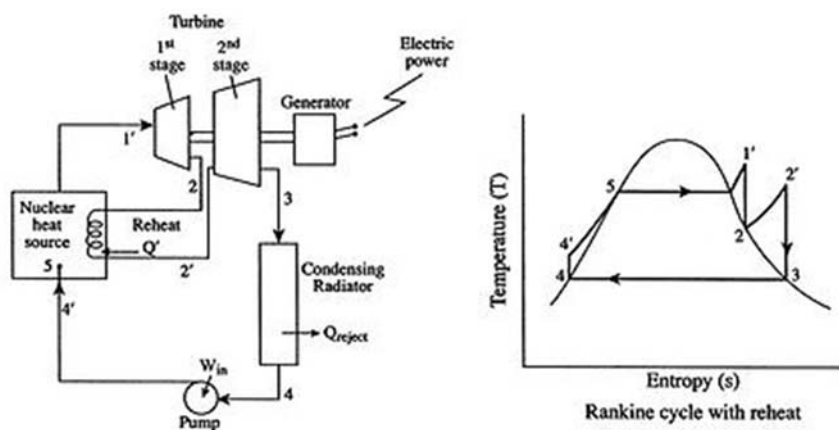

Figure 5 Principle sketch (left) and temperature-entropy diagram (right) of a Steam Rankine cycle with reheat [3]

## 2.2 Rankine cycle with other working fluids

### 2.2.1 Basic Rankine cycle

The basic Rankine cycle (RC) is similar to the Steam Rankine cycle in operating principles, but other working fluids than water are used to make the cycle efficient for heat source temperatures down to  $\sim 80^\circ\text{C}$ . Working fluids used in basic RCs are typically "dry" or "isotropic", meaning that the slopes of their dew point curves are either positive or zero, e.g. pentane (dry) or R134a (isotropic) in Figure 4. Their critical temperatures are also lower than that of water. Such fluids may eliminate the need for superheating, sub-atmospheric condensation pressure, and need for auxiliary systems. This, combined with lower



maintenance requirements than for steam cycles, makes the basic RC applicable for decentralised and small scale power plants with electric outputs as low as 5 kW. The cycle can also be used in high capacity plants with power outputs up to several MW [2, 4].

The basic RC is widely commercialized, and is the most mature technology for low-to-medium temperature heat recovery. However, there are several challenges with the basic RC, including low cycle efficiency, high back work ratio (pumping power relative to expander power), as well as flammability and high GWP of working fluids. Different cycle modifications have been suggested to increase the performance of the cycle. These typically introduce new components or working fluids to reduce cycle exergy losses and increase work output. The cycles may appear theoretically similar, but require different process layouts and complexity, which impacts cycle costs and feasibility. Different RC technologies are discussed in the following sections in this chapter.

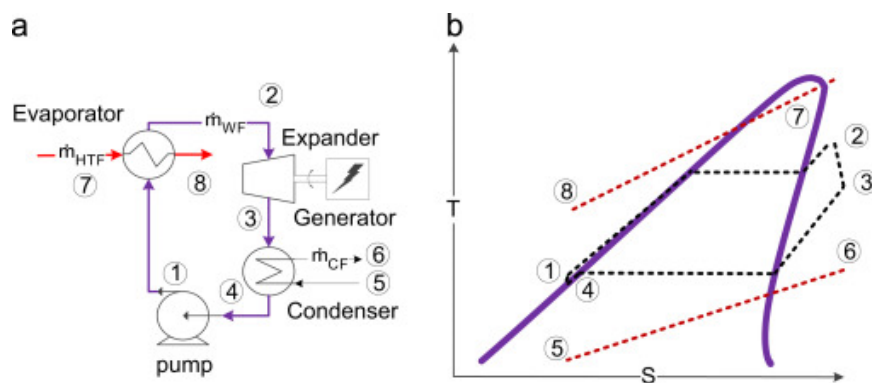

Figure 6 Principle sketch (a) and temperature-entropy diagram (b) of a basic Rankine cycle [5]

### 2.2.2 Recuperated Rankine cycle

A recuperated Rankine cycle includes an internal heat exchanger that lets the expander outlet stream preheat the pump outlet stream before it enters the evaporation, as sketched in Figure 7a. The recuperator reduces the specific enthalpy change during evaporation ( $\Delta h$ ), which allows a higher working fluid mass flow for the same heat input ( $\dot{Q} = \dot{m} \cdot \Delta h$ ), and increases work output. Another way of explaining the improvement with a recuperator is that it improves the temperature match between the working fluid and the heat source and sink. This improves work output, as explained in Section **Error! Reference source not found.**

Two criteria need to be present for a recuperator to be useful. Firstly, a significant desuperheating region needs to be present prior to condensation and secondly, there should be a lower limit on the heat source outlet temperature [6]. A recuperator is typically useful for industries with lower limits on heat source outlet temperature, such as aluminium industry where the waste heat typically cannot be cooled to less than 80°C because of acid condensation or downstream gas cleaning processes [6].

A disadvantage of recuperated RCs is the requirement of an additional process component, which increases cycle investment costs. Larger heat exchangers, or heat exchanger surface area, may also be necessary to increase performance with a recuperator. Experimental research has demonstrated improved cycle efficiency with the use of a recuperator, and a recuperated cycle has been developed and put into operation by RC manufacturers such as Turboden [2, 5].

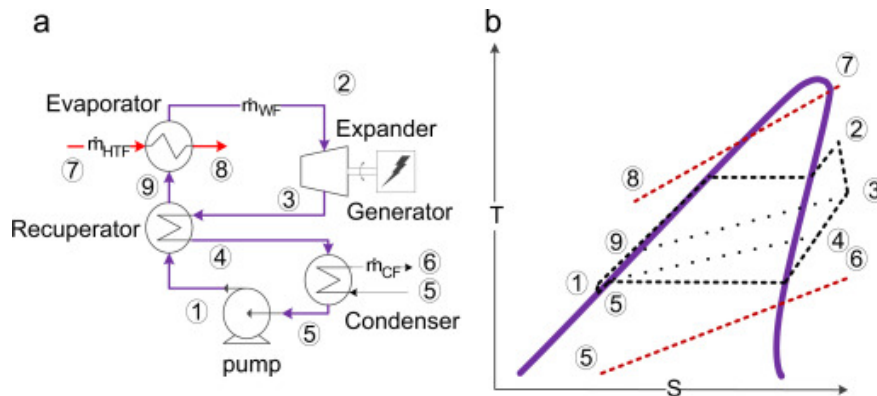
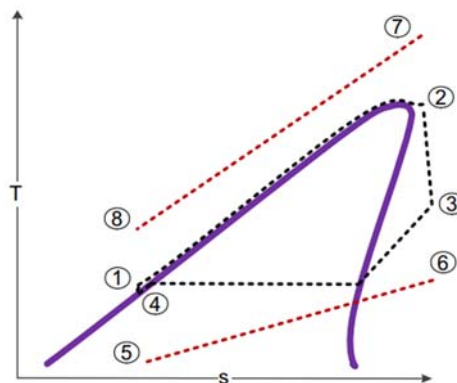

Figure 7 Principle sketch (a) and temperature-entropy diagram (b) of an RC with recuperator [5]

### 2.2.3 Transcritical Rankine cycle

A transcritical Rankine cycle is similar to the basic RC, except that the working fluid absorbs heat at a pressure above critical pressure, as sketched in Figure 8 (1-2). This causes heat input to occur at a gliding temperature change of the working fluid, allowing for an improved temperature match between the working fluid and heat source. In a transcritical cycle, the evaporator is replaced by a heater, but otherwise, the process layout is quite similar to a basic RC. However, transcritical cycles may have higher operating pressures which could limit component availability and affect cost. Other challenges reported in the literature include supersonic flows (fluid speed > sonic speed), large volume ratios across the expander and high pumping power requirements [6].

SINTEF Energy Research has studied transcritical CO<sub>2</sub> and transcritical hydrocarbon Rankine cycles in projects such as KMB Effort, KMB Roma and COPRO. There is a limited number of commercially available low- to medium temperature transcritical systems, but there is currently an available CO<sub>2</sub> system for high temperature heat recovery (532°C) from Echogen. Demonstration plants have shown promising results in the low- to medium temperature range, such as a prototype plant developed by Turboden that was put into operation by Enel in 2012. The plant operated with a nominal heat source temperature of 152°C and produced a net power of 364 kW at design condition. An improvement of 15-20 % in net annual power output compared to subcritical operation of the plant was demonstrated, as well as improved operational flexibility [7].



**Figure 8 Temperature-entropy diagram of a transcritical Rankine cycle. The numbers refer to the sketch in Figure 6a [5]**

### 2.2.4 Trilateral flash cycle

In the trilateral flash cycle (TFC), the working fluid expands directly from saturated liquid and into the two-phase region (2-3 in Figure 9), such that no evaporation takes place during heat input from the heat source. As a result, the temperature match in the heater is improved. Analytical studies have shown that the TFC outperforms the basic RC in terms of exergy efficiency, and the transcritical cycle in terms of heat recovery [5]. Some suggest that the investment cost of a TFC could be lower than an RC due to a simpler system [8].

The TFC requires specifically designed two-phase expanders, which have lower efficiencies than conventional vapor-phase expanders. A paper by SINTEF Energy Research (submitted to the Gustav Lorentzen conference in 2018 [9]) accounted for lower expander efficiency, and showed that this penalizes the TFC-performance compared to the basic RC. Still, the TFC achieved up to 10 % higher work output than the basic RC for a heat source a 100°C, but the performance was comparable for heat sources at 150°C and 200°C. Other challenges with the TFC were higher heat exchanger area, expander outlet volume and pumping power relative to expander power. Higher areas were caused by a closer temperature match during heat absorption, as well as lower heat transfer coefficients during one-phase heat transfer compared to what is commonly seen for boiling in an evaporator. Higher specific pumping power was caused by a lower specific enthalpy change during heat absorption, which increased mass flow.

The TFC, including development of two-phase expanders, is still in the research phase, but pilot plants have demonstrated successful operation of the technology by using a commercially available two-phase expander [10].

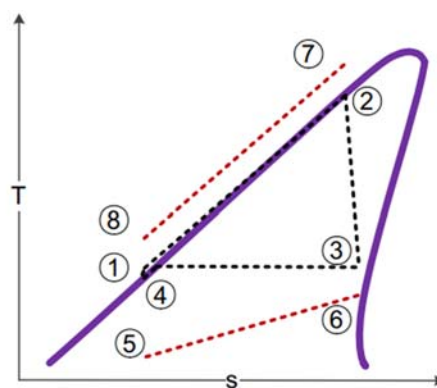

**Figure 9 Principle temperature-entropy diagram of a trilateral flash cycle. The numbers refer to the sketch in Figure 6a [5]**

### 2.2.5 Partially evaporating cycle

The partially evaporating cycle (PEC, Figure 10) is similar to the TFC but, as the name suggests, allows partial evaporation of the working fluid. Partial evaporation will "remedy" some of the disadvantages of the TFC compared to the RC; heat exchanger area will be reduced due to higher heat transfer coefficients and greater temperature differences in the heater/evaporator, and the pumping power is reduced due to a

lower working fluid mass flow. At the same time, heat recovery is reduced due to a poorer temperature match during heat absorption. Partial evaporation will also add complexity to the heat exchanger compared to the single-phase heat transfer of a TFC. Consequently, the PEC can be optimized to combine the advantages of the TFC and RC [11, 12].

The partially evaporating cycle was analysed and compared to an RC by Trædal, Rohde [12]. They considered variable expander efficiency and detailed heat transfer and pressure drop models, and found that the PEC achieved 3 % higher work output than the RC for a heat source temperature of 100°C, and required approximately the same heat exchanger area. The PEC did not show any improvement for heat sources at 150°C and 200°C. The TFC was also studied, and showed the poorest performance.

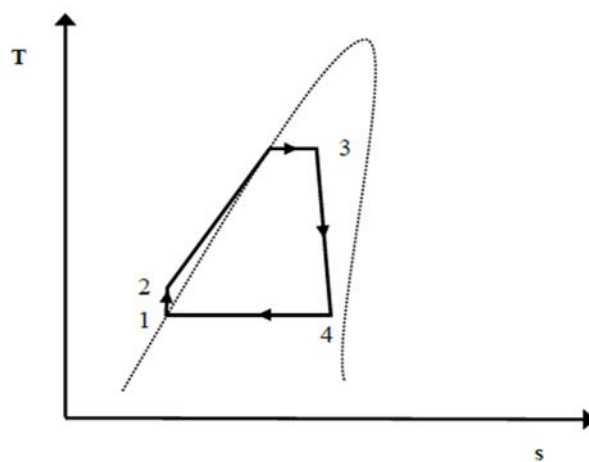

Figure 10 Principle temperature-entropy diagram of a partially evaporating cycle [13]

### 2.2.6 Flash cycle

The flash cycle (FC), illustrated in Figure 11, is similar to the TFC, except that the working fluid is separated into liquid (10) and vapor (2) in a flash tank after the heater. The vapor proceeds to the expander, whereas the liquid is throttled down to the low-side pressure (10-11), where it is mixed with the vapor exiting the expander. The arrangement eliminates the two-phase expansion of TFCs and PECs, while the close temperature approach in the heater is maintained. Despite improved heat recovery, previous studies have indicated that throttling losses reduce cycle efficiency and work output compared to an optimized, basic RC [5]. Separation of liquid and vapor before expansion also reduces the mass flow through the expander.

Different cycle modifications are possible, such as replacing the throttling valve with a two-phase expander or flashing the working fluid in two steps, where the vapor from each step is fed to two different expander stages. Such modifications have been shown to improve work output between 5-20 % for hydrocarbons when comparing to an optimized RC, but only between 2-4 % improvement for siloxanes [5].

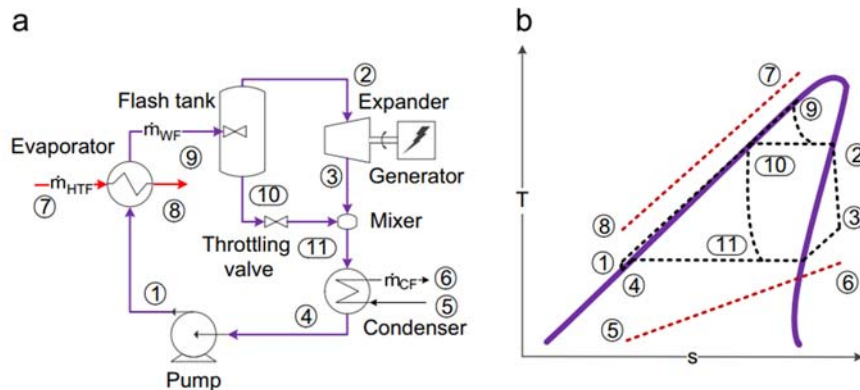

Figure 11 Principle sketch (a) and temperature-entropy diagram (b) of a flash cycle [5]

An alternative FC is shown in Figure 12. The fluid is partly evaporated and flashed in two stages, where the vapor from both flash tanks is fed to the expander (2 and 12). Instead of mixing the liquid and vapor after expansion, the liquid from the second flash tank (10) is fed directly to a pump ("Pump 2") and back to the heater. For heat sources between 90°C and 160°C and using organic working fluids, this has been shown to give between 4-25 % improvement compared to a basic RC, but the study in question only considered partly optimized cycles. This arrangement may necessitate two heaters and an extra expander, and is less implemented than systems with one flash tank, which is common in geothermal power plants [14].

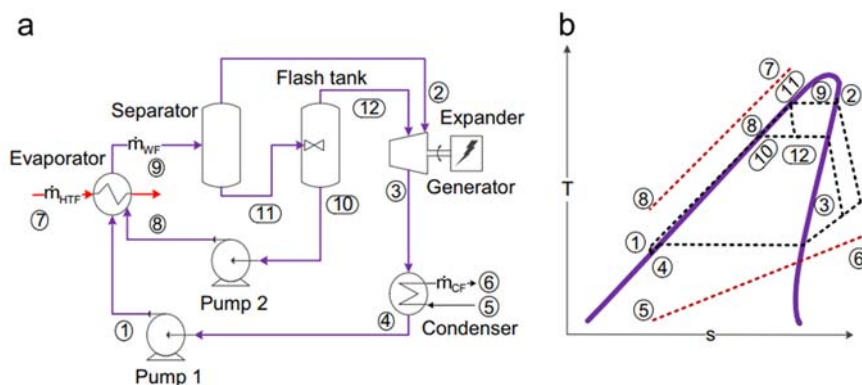

Figure 12 Principle sketch (a) and temperature-entropy diagram (b) of an alternative flash cycle [5]

### 2.2.7 Dual pressure cycle

A dual pressure cycle, or "two-stage" cycle, is sketched in Figure 13. The cycle is theoretically similar to a basic ORC, but has two evaporation pressures and necessitates two evaporators, expanders and pumps. The heat source is cooled in series through the two evaporators, and the working fluid is split and pumped to two different pressure levels to receive heat in the evaporators. It is also possible that two heat sources at different temperature levels enters the evaporators in parallel. Dual pressure cycles allow improved temperature match with the heat source(s) and lower heat source outlet temperature, and increases heat recovery [15].

Several analytical studies of dual pressure cycles have demonstrated improved performance compared to the basic cycle. For instance, one study showed 25 % improvement in work output for a heat source at

100°C [5], and another showed 21 % improvement for a heat source at 175°C [3]. The improvement in performance comes with added cycle complexity and equipment costs. Dual pressure cycles are likely only profitable for high capacity units that can exploit the additional efficiency, for example in geothermal, cement and steel production industries [15]. Dual pressure systems are already commercialized within the geothermal sector, with technology providers such as Ormat Technologies [5].

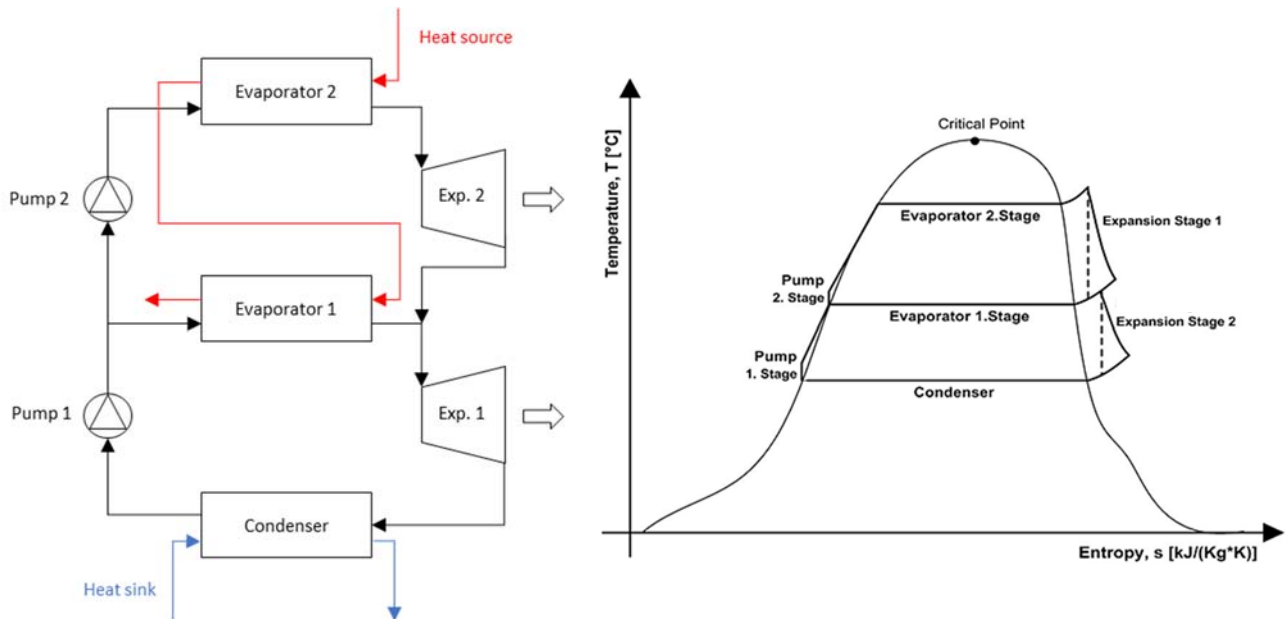

Figure 13 Principle sketch (made inhouse) and temperature-entropy diagram of a dual pressure cycle [16]

### 2.2.8 RC with zeotropic mixtures as working fluid

An RC with a zeotropic mixture as working fluid is illustrated in Figure 14, where temperature glides are present during evaporation and condensation. The temperature glides during evaporation and condensation are created by the different boiling point temperatures of the fluid components in the mixture, and improve temperature match in the heat exchangers. Contrary to the transcritical cycle and other technologies with gliding temperature during heat absorption, mixtures reduce exergy losses in the condenser as well as the evaporator.

To improve the annual efficiency of RCs with fluctuating ambient (or heat sink) temperature, dynamic mixture composition control can be used. Changing the mixture composition controls the temperature glide during condensation, and could be tuned to e.g. enable lower condensing temperatures in cold periods. This has been shown to improve efficiency by up to 23 % for a heat source at 100°C [17].

RCs with working fluid mixtures may require slightly higher heat exchanger areas than basic RCs, both due to reduced heat exchanger temperature differences and lower heat transfer coefficients. Other challenges include limited knowledge of heat transfer and pressure drop of zeotropic mixtures, as well as a risk of fluid fraction [5]. Moreover, there is limited availability of experimental research on the use of mixtures. An experimental study by Wang, Zhao [18] demonstrated improvement compared to pure fluid, and confirmed the possibility for capacity adjustment with composition variation.

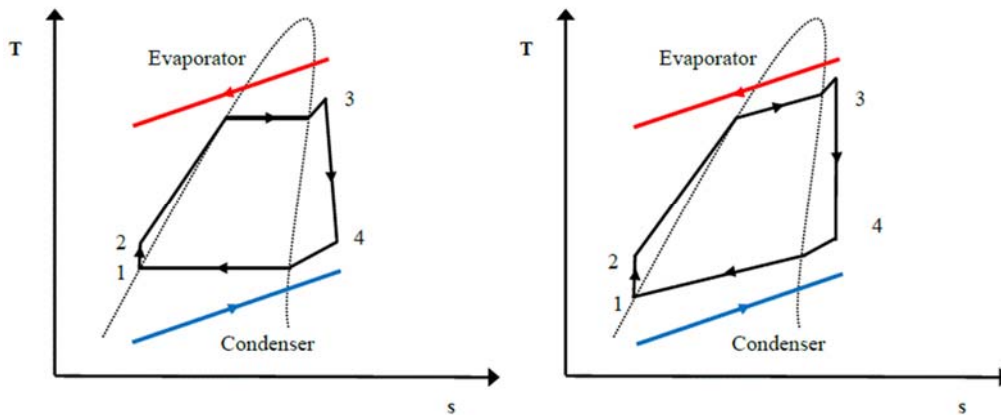

Figure 14 Principle temperature-entropy diagram of an RC with pure working fluid (left) and an RC with mixed working fluid (right) [13]

### 2.2.9 Other Rankine cycle architectures

Several other RC architectures and configurations exist, but are currently considered to be less relevant for the current applications. Some of the more established are discussed briefly in the following.

#### Cascade RC

In a cascade RC, shown in Figure 15, two RCs are combined through a common heat exchanger (cascade heat exchanger) that acts as the condenser of the top cycle and the evaporator of the bottom cycle. The cycle receives heat in the evaporator of the top cycle, and rejects heat in the condenser of the bottom cycle. The top and bottom cycles can use different fluids that are optimized for the heat source and heat sink, respectively, which improves cycle efficiency. However, an extra heat exchanger introduces additional heat exchanger exergy loss in the cycle, which may be high compared to the total exergy content in low-to-medium temperature heat sources.

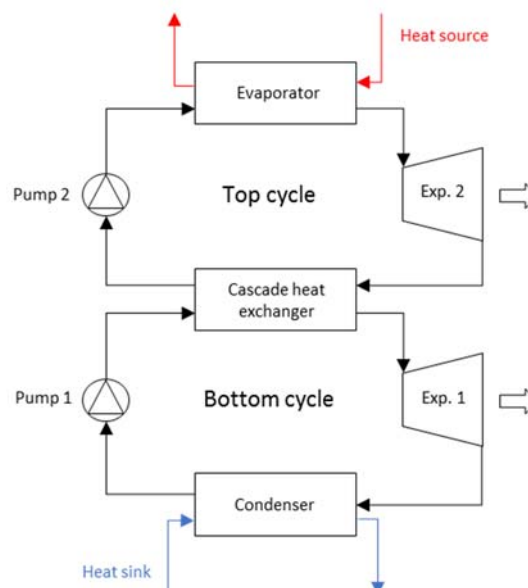

Figure 15 Principle sketch of a cascade RC

### Regenerative RC with turbine bleeding

Regenerative cycles with turbine bleeding are common implementations in Steam Rankine cycles, but can also be used in RCs. In the cycle, a fraction of the working fluid is extracted from the expander (point 8 in Figure 16) and used to preheat, or regenerate, the working fluid. The effect on cycle performance is similar to that of a recuperator, with possibility for improved performance when there is a lower limit on heat source outlet temperature [19]. A drawback of turbine bleeding compared to a recuperated cycle is additional process components, and a recuperator has been shown to result in a better thermodynamic performance for a low temperature heat source [20]. Turbine bleeding may be an efficient solution for combined heat and power cycles.

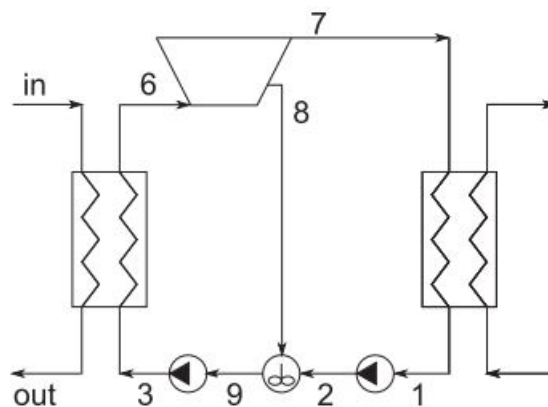

Figure 16 Principle sketch of a regenerative RC with turbine bleeding

### Regenerative RC with vapor injector

A vapor injector can be placed after the condenser and receive a fraction of working fluid from the expander to preheat/regenerate the working fluid. The benefit is similar to a recuperated or a regenerative RC. An RC with vapor injector has been shown to achieve slightly better thermal performance than an RC under certain operating conditions [21].

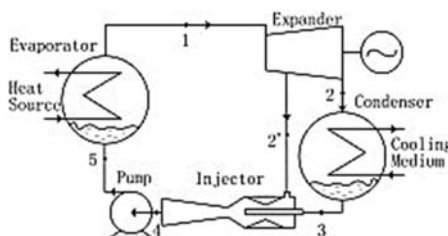

Figure 17 Principle sketch a regenerative RC with vapor injector [21]



## Supercritical cycle

In a fully supercritical cycle, also known as a Brayton cycle (very commonly used in combustion driven processes, e.g. gas turbines), both heat input and heat rejection takes place above critical pressure, as illustrated in Figure 18. As with a transcritical cycle, the evaporator in a basic RC is replaced with a heater (2-3). In addition, the condenser is replaced with a cooler (4-1), and the pump is replaced with a compressor (1-2). Like a transcritical cycle, temperature match is improved during heat input, which reduces heat exchanger exergy loss. Challenges are related to relatively large compressing power and high operating pressures, as well as unstable amounts of liquid and vapor in the supercritical phase. The latter might necessitate a two-phase expander [4].

Barber Nichols developed and tested a full-scale CO<sub>2</sub> Brayton cycle for high temperature heat sources of up to 700°C, and found that performance improved by 7-12 % compared to a traditional steam cycle [22].

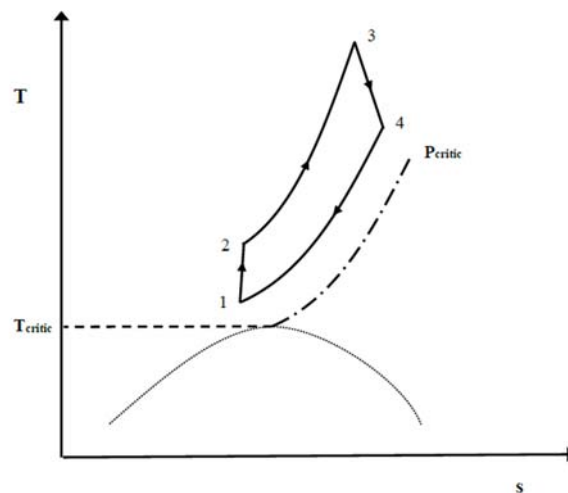

Figure 18 Principle temperature-entropy diagram of a supercritical cycle [13]

## 2.3 Absorption cycles

A principle sketch of an absorption cycle is given in Figure 19. In absorption cycles, one fluid is cyclically absorbed and desorbed into another fluid. The condenser is replaced by an absorber, where heat is released to the heat sink during absorption (10-11). Similarly, the evaporator is replaced by a desorber, where heat input separates the two working fluid components (2-4). After the fluids have been separated, one component enters the evaporator (5-6), and the other is cooled in a recuperator (7-8), and throttled down to the low-side pressure (8-9), where it is mixed with the other component (9-10). The use of two fluids, or a working fluid mixture, allows for improved temperature match in the heat exchangers.

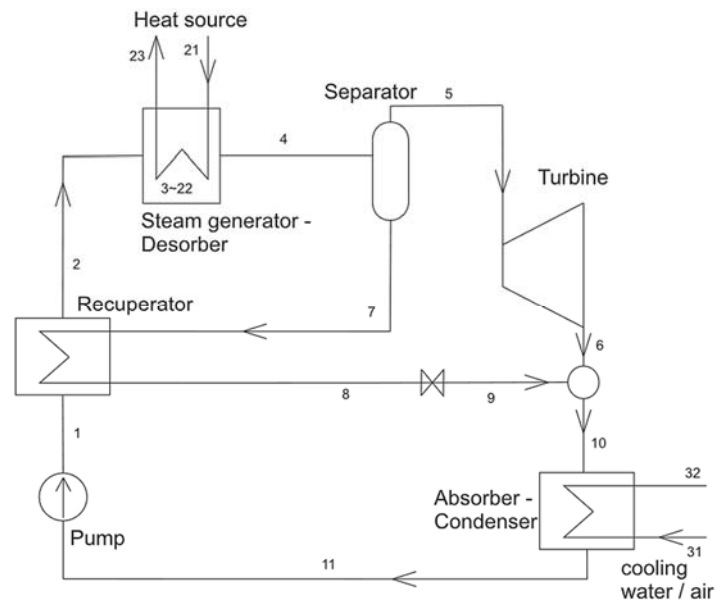

Figure 19 Principle sketch of an absorption cycle [23]

### 2.3.1 Kalina cycle

The Kalina cycle, sketched in Figure 20, is an absorption type cycle that uses a mixture of water and ammonia as working fluid. The condenser is replaced by an absorber where ammonia is absorbed into water, and the components are separated in a flash tank. For an explanation of how the process operates, see Ibrahim and Klein [24].

The Kalina cycle has a higher theoretical efficiency than the RC, but under certain operating condition, the Kalina cycle has been shown to perform poorer than the RC [19]. The cycle also requires several additional components and a relatively complex process compared to a basic RC, which results in a more costly system. There are also challenges related to ammonia as a working fluid due to its toxicity [4]. Several Kalina cycles have been installed in industry, but licencing conditions seem to have slowed down further implementation and independent research of the cycle.

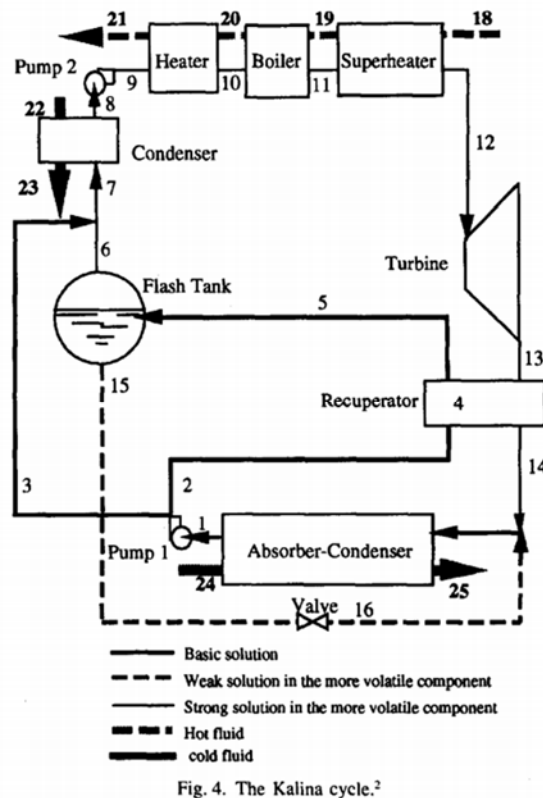

Figure 20 Principle sketch of the Kalina cycle [24]

### 2.3.2 Salt-water absorption cycle

Salt-water absorption cycles are in principle similar to Kalina cycles, but aqueous salt solutions are used instead of ammonia. Novotny and Kolovratnik [23] studied the performance salt-water absorption cycles and compared it to basic RCs with different working fluids for heat sources between 60°C and 160°C. Aqueous salt solutions of LiCl, LiBr and CaCl<sub>2</sub> were considered, and were found to outperform basic RCs for heat source temperatures of 120°C and lower. For heat sources below 80°C, the absorption cycles obtained as much as 150 % higher efficiency than the RCs. The authors indicate challenges with low operating pressures (vacuum) and corrosiveness of aqueous salts.

### 2.3.3 Carbon carrier cycle

Climeon has developed and patented a CO<sub>2</sub>-amine absorption cycle named Carbon carrier cycle (CCC). In the cycle, CO<sub>2</sub> is absorbed into an amine downstream of the turbine, which effectively lowers the turbine exit pressure and temperature. Climeon claims that the cycle can produce up to three times more electricity than currently available technologies for low-to-medium temperature heat-to-power conversion [25].

## 2.4 Stirling engine

The Stirling engine was patented by Robert Stirling in 1816, and is a relatively mature technology for heat-to-power conversion [4]. A possible arrangement of the engine is sketched in Figure 21, where gas is contained in two cylinders connected by an internal heat exchanger. The gas inside one of the cylinders expands as heat is received from the heat source, and the gas inside the other cylinder is compressed as heat is rejected to a heat sink. Exchange of heat between the hot and cold gas is realized through the internal heat exchanger. This arrangement allows cyclical expansion and compression of the gas, which rotates a flywheel and generates mechanical work.

The Stirling engine has relatively high energy efficiency in low-capacity power plants, and the engine is silent and vibration free [26]. However, the engine has a low power to weight ratio and is unsuited for plants on the order of 1 MW power output and higher, where the RC has superior efficiency [4, 27]. Moreover, the engine is not suited for sensible cooling, and several engines have to be placed in series to utilize sensible heat [4].

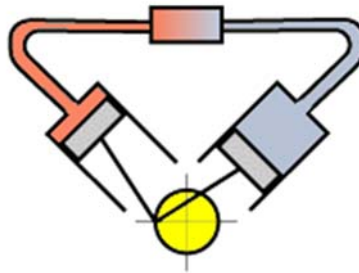

Figure 21 Principle sketch of a possible arrangement of the Stirling engine [28]

## 2.5 Thermoelectric generator

The thermoelectric generator (TEG) is a technology that directly converts heat into electricity, as opposed to Rankine cycles that first convert heat into mechanical energy. There are several such technologies, including thermoelectric, piezoelectric, thermionic and thermo-photovoltaic generation. Recently, the TEG has gained attention as a viable technology for low-to-medium temperature heat-to-power conversion.

The TEG is built up of thermoelectric modules, as sketched in Figure 22. A module consists of two semiconductors that conduct electricity when exposed to a temperature difference across their ends, which is created by a heat sink and a heat source. Negative charges move downwards in an n-type semiconductor (blue) and positive charges move downwards in a p-type semiconductor (yellow). When the two conductors are connected, an electric current is created and power is produced. Heat exchangers are installed on the hot and cold side to provide efficient heat exchange to and from the conductors.

The first TEG was used in a satellite as early as 1961, and TEGs are commonly installed in space probes due to their "extreme reliability" [29]. The main advantages of the TEG for waste heat recovery compared to RCs is lower weight and the absence of moving parts. The technology is also quiet, reliable and environmental friendly. However, wide application of the technology is slowed down by high material costs and low energy conversion efficiency, which is typically less than 10 % [2, 29]. Concepts demonstrating utilization of large capacity, finite industrial surplus heat has so far not shown promising results [4]. The TEG can be a viable option for waste heat recovery where conventional systems are difficult to implement or if less costly materials are developed [29]. In HighEFF, a dedicated report on TEG is planned to be published in December 2017; D3.1\_2017.03 *Evaluation of TEG on industrial scale implementation*.

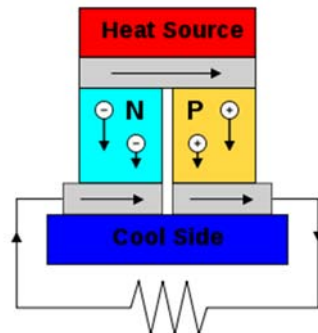

Figure 22 Principle sketch of the a thermoelectric module [30]

## 2.6 Membrane technology

TNO have developed and patented a membrane technology called MemPower<sup>®</sup>, which both desalinates saltwater and produces power from low-to-medium temperature heat. Power production is realized by expanding high pressure steam that is produced during desalination through a turbine. The technology is primarily intended for use in regions with a shortage of clean drinking water, and is particularly useful in areas with high availability of sun and lacking electricity infrastructure [31].

## 2.7 PCM technology

As heat is transferred to a phase change material (PCM), the material changes phase from liquid to solid, causing volume expansion that can be used to generate mechanical work. After the PCM has expanded, it is cooled by a heat sink, which causes its volume to decrease to the original value and allows for a cyclical power process. NASA and Exencotech have patented different types of PCM power technologies that are currently in the research and development phase. Exencotech have demonstrated an energy efficiency of 7.5 % for a heat source temperature of 95°C, as well as an electric output of 1 kW for a single "energy cell". The company is reportedly planning to develop systems that produce up to 1 MW electric output [4].

### 3 Evaluation and summary

The different technologies for heat-to-power conversion are described and evaluated in Table 1. Evaluation is performed in a HighEFF context, as explained in Section **Error! Reference source not found.** The evaluation is based on initial research into the field and is purely qualitative, and will serve as input to quantitative evaluations in future work.

The technologies are evaluated in the three categories "maturity", "complexity" and "performance", and ranked with the color codes given in Table 2. Green, or "high" ranking is the best score that a technology can achieve in a specific category. The meaning assigned to each category is explained below.

**Table 2 Description of color codes for ranking of technologies in the categories maturity, complexity and performance.**

LOW	MEDIUM	HIGH
-----	--------	------

#### Maturity

This category refers to the level of maturity of the technology within low-to-medium temperature waste heat recovery. Technologies in early stages of development are ranked as low, and commercialized technologies are ranked as high. Technologies with some installed plants or pilots with significant duration of operation are ranked as medium. High maturity can be correlated with high availability and low-cost components, but mature technologies are also likely to have lower potential for further improvements to costs and performance.

#### Simplicity

This category refers to the degree of complexity of the technology. Technologies with many and/or complex components and complex process layouts will score low in this category. High complexity is correlated with high costs and low robustness, and complex technologies will require longer time to reach maturity.

#### Performance

Performance refers to the maximum power output that a technology can produce from a given heat source, and is related to the exergy efficiency of the process. It is desirable to have the highest possible performance per unit cost or system size. Performance is evaluated for HighEFF heat sources in the temperature range 150-200°C. Other characteristics of HighEFF heat sources include high duty and sensible heat.

**Table 1 Evaluation of technologies for heat-to-power conversion from heat sources in temp. range 150-200°C**

Group	Technology	Maturity	Simplicity	Performance	Technology description and evaluation basis
Classic technologies	Steam Rankine cycle				Conventional technology for high temperature heat-to-power conversion. Power is produced by expanding pressurized water through an expander. Not mature and has low performance in relevant temperature range.
	Stirling engine				Cyclical expansion and compression of gas drives rotation of a flywheel. High efficiency for small scale plants, but has scale up challenges and is poorly suited for sensible cooling. Not mature and has low efficiency in large scale waste heat recovery.
RC family	Basic RC				Operating principles similar to the steam cycle, but working fluids are adapted for low-to-medium temperature heat recovery. Thermodynamic potential limited by low heat source temperatures. Simple system and mature for low-to-medium temperature heat sources.
	RC with mixture as working fluid				Pure working fluid in RC replaced with zeotropic working fluid mixture. Temperature match in evaporator and condenser improved. Does not add system complexity, but affects heat transfer. Maturity low due to absence of experiments and demonstration plants.
	Transcritical RC				RC with evaporation pressure above critical pressure, which improves temperature match with heat source. Simple system, only difference from basic RC is that evaporator is replaced with heater. Medium performance, as demonstrations plants have shown promising results.
	Trilateral flash cycle, TFC				Fluid expands from liquid into two-phase region, which requires two-phase expander and improves temperature match in heater. Two-phase expanders have low maturity and increase process complexity. Medium performance due to low expander efficiency and high pumping power.
	Partially evaporating cycle, PEC				Similar to TFC, but allows partial evaporation of working fluid. Reduces pumping power and size of heater compared to equivalent TFC, but also gives poorer temperature match in heater. Maturity, simplicity and performance similar to TFC.
	Flash cycle, FC				Similar to TFC, but separation of liquid and vapor prior to expansion eliminates two-phase expansion. Introduces additional throttling losses, and reduces mass flow through expander. More complex system than the TFC, but higher maturity as two-phase expander is not required.
	Dual pressure cycle				Evaporation of working fluid at two pressure levels. Heat recovery from heat source improves, resulting in improved performance compared to basic RC. Mature in geothermal sector, not implemented in industrial waste heat recovery. Complex system with multiple components.
	Absorption cycles				Kalina cycle, CCC and salt-water absorption cycle. Evaporator of RC replaced with desorber, and/or condenser replaced with absorber. Thermodynamic performance improves, relatively complex system. Kalina cycle is commercialized, but the other cycles have low maturity.
Other technologies	TEG				Produces electricity directly from heat with semiconductors that conduct electricity when exposed to temperature difference. Concepts utilizing larger, finite heat sources not demonstrated, but possible option where conventional cycles are difficult to implement. Relatively low efficiency
	Membrane technology				Developed for desalination of water, but also produces high pressure steam that is expanded through a turbine to produce power. Could be suitable for regions with lacking drinking water and electricity infrastructure. Not developed for industrial scale heat. Relatively complex.
	PCM technology				Cyclical expansion and contraction of phase change material realises production of mechanical work. Currently in early stages of development, but plans exist to develop a 1 MW system. A relatively low efficiency of 7.5 % has been demonstrated.

A range of technologies are available for heat-to-power conversion, where the most conventional technology is the Steam Rankine cycle. However, the steam cycle is adapted for heat sources above 450°C, and is not suited for low-to-medium temperature heat recovery. The basic RC is a mature technology in this temperature range, but its performance is limited due to low heat source temperatures. Several modified RC architectures have been developed to improve the performance of basic RCs.

Of the simpler RC technologies is the recuperated and the transcritical cycles. These systems have potential to increase performance with either a single extra component (recuperated cycle) or by replacing the evaporator with a heater (transcritical cycle). The cycles are relatively mature, and a pilot plant has already demonstrated successful operation of a transcritical RC. Other simple systems include the TFC and PEC, but these have challenges related to lack of research and availability of two-phase expanders. Of the two, previous studies indicate that the PEC has greater potential. FCs can eliminate the two-phase operation of TFCs, but modest analytical results for TFCs and the relative complexity of FCs indicate a low techno-economic performance of the FC. The dual pressure cycle is another complex technology, for which research has shown promising results. Other RC architectures have been briefly discussed, but are less relevant in a HighEFF context.

An interesting RC modification is the use of working fluid mixtures, which does not significantly alter the process, but improves temperature match in the heat exchangers. Mixtures have potential to increase performance with relatively low system costs, and can contribute to improved net annual performance with dynamic composition control. Possible innovative technologies include the use of mixtures in transcritical cycles or PECs, which can further improve performance of such cycles compared to basic RCs.

Absorption cycles are relatively complex, and research has demonstrated both poorer and improved performance compared to basic RCs. Both the Kalina and the Carbon Carrier cycles have licencing strategies that seem to slow down commercialization, and the salt-water absorption cycle may be a more promising technology for broader industrial implementation. Several other technologies for heat-to-power conversion exist, including the Stirling engine, TEG, membrane- and PCM technologies. These have advantages that favour certain applications, but are less relevant for large-scale industrial surplus heat.

Some researchers have performed comparative studies of different heat-to-power technologies, such as Becquina and Freund [32], who compared transcritical cycles, Kalina cycles and dual pressure cycles to the basic RC. The study found that the highest performing technology depends on the heat source temperature. Below ~120°C, the Kalina cycle had the highest work output and above, transcritical cycles performed highest. The transcritical cycle was closely followed by dual pressure cycles in the higher temperature range. The cycles outperformed the basic RC for most heat source temperatures, but the improvement reduced with heat source temperature, where the baseline performance of basic RCs is higher. The study compared technologies with similar heat exchanger pinch points, and thus different UA-values, or heat exchanger sizes. The authors tested two sets of pinch points, and concluded that differences in heat exchanger sizes is at least as important for performance as the choice of technology. Thus, comparing technologies with the same heat exchanger sizes is important in "fair" comparison. Choice of working fluid and optimization model also impact the optimum performance of different cycles, and are also important considerations.



## 4 Conclusions and future work

A number of heat-to-power technologies are available for heat-to-power conversion. The current evaluation of technologies will serve as basis for proposed activities in 2018, which includes a quantitative evaluation of promising technologies for prioritized HighEFF cases. Several conclusions and inputs for further evaluation are listed in the following.

- Rankine cycle based technologies and absorption cycles appear most suited in a low-to-medium temperature HighEFF context.

An evaluation of different technologies indicates that transcritical cycles, dual pressure cycles, absorption cycles and use of zeotropic mixtures as working fluid gives slightly higher thermodynamic performance than other technologies. Recuperated cycles are relevant for heat sources with lower limits on outlet temperature.

- Relevant technologies have different complexity and costs. Of the high performing cycles, transcritical cycles and use of zeotropic working fluid mixtures is relatively simple, while dual pressure cycles and absorption cycles are relatively complex and capital intensive.
- Heat exchanger size is at least as important for performance as choice of technology. Fair comparison between different technologies in terms of equal system size should be implemented to evaluate technologies on the same basis. This will be a step in the direction of evaluating technologies with similar heat exchanger costs.
- Heat source temperature and characteristics impact the choice of technology. For instance, relatively low heat source temperatures give poor baseline performance of basic RCs, and alternative architectures will provide more benefit.
- As performance depends on heat exchanger sizes and heat source temperature, technologies should be evaluated over a relevant range of UA-values (heat exchanger size) and heat source temperatures.

## References

1. Reddy, V., et al., *An Approach to Analyse Energy and Exergy Analysis of Thermal Power Plants: A Review*. Smart Grid and Renewable Energy, 2010. **1**(3): p. 143-152.
  2. Quoilin, S., et al., *Techno-economic survey of Organic Rankine Cycle (ORC) systems*. Renewable and Sustainable Energy Reviews, 2013. **22**: p. 168-186.
  3. Guzović, Z., P. Rašković, and Z. Blatarić, *The comparison of a basic and a dual-pressure ORC (Organic Rankine Cycle): Geothermal Power Plant Velika Ciglena case study*. Energy, 2014. **76**(Supplement C): p. 175-186.
  4. Christophersen, E.B., N. Houbak, and M.M. Ragnøy, *Kraftgjenvinning fra lavtemperatur spillvarme*. 2014, Rambøll.
  5. Lecompte, S., et al., *Review of organic Rankine cycle (ORC) architectures for waste heat recovery*. Renewable and Sustainable Energy Reviews, 2015. **47**: p. 448-461.
  6. Agromayor, R., *Turbomachinery design for Rankine cycles in waste heat recovery application*, in *Institute of Energy and Process*. 2017, NTNU.
  7. Astolfi, M., et al. *Testing of a new supercritical ORC technology for efficient power generation from geothermal low temperature resources*. in *ASME ORC 2013, 2nd international seminar on ORC power systems*. 2013. De Doelen, Rotterdam, The Netherlands.
  8. Welch, P. and P. Boyle, *New Turbines to Enable Efficient Geothermal Power Plants*. Geothermal Resources Council Transactions, 2009. **33**: p. 765-772.
  9. Rohde, D., et al. *Comparison of ORC and TFC for power production from low temperature waste heat sources (Submitted)*. in *13th Gustav Lorentzen conference on natural refrigerants*. 2018. Valencia , Spain.
  10. Boyle, P., et al. *Performance of Variable Phase Cycle in Geothermal and Waste Heat Recovery Applications*. in *GRC Annual Meeting*. 2013. Emergent Corporation.
  11. Lecompte, S., M.v.d. Broek, and M.D. Paepe. *Thermodynamic analysis of the partially evaporating trilateral cycle*. in *2nd International Seminar on ORC Power Systems*. 2013. Rotterdam, Netherlands.
  12. Trædal, S., D. Rohde, and T.M. Eikevik. *Analysis of the trilateral flash cycle and the partially evaporating cycle for power production from low temperature heat sources*. in *Proceedings of the 11th IIR-Gustav Lorentzen Conference on Natural Refrigerants GL2014*. 2014.
  13. Shahrooz, M. and P.P. Lundqvist, *Literature survey on potential working fluids and mixtures for low temperature power cycles*. 2016, KTH Royal Institute of Technology
- SINTEF Energy Research Center.
14. Edrisi, B.H. and E.E. Michaelides, *Effect of the working fluid on the optimum work of binary-flashing geothermal power plants*. Energy, 2013. **50**: p. 389-394.
  15. Astolfi, M., *3 - Technical options for Organic Rankine Cycle systems*, in *Organic Rankine Cycle (ORC) Power Systems*. 2017, Woodhead Publishing. p. 67-89.
  16. *Analysis of organic Rankine cycle as application for waste heat utilization in cogeneration units with combustion engines*. [cited 07.12.17]; Available from: [http://www.hs-bremen.de/internet/de/forschung/projekte/detail/index\\_15628.html](http://www.hs-bremen.de/internet/de/forschung/projekte/detail/index_15628.html).
  17. Collings, P., Z. Yu, and E. Wang, *A dynamic organic Rankine cycle using a zeotropic mixture as the working fluid with composition tuning to match changing ambient conditions*. Applied Energy, 2016. **171**: p. 581-591.
  18. Wang, J.L., L. Zhao, and X.D. Wang, *A comparative study of pure and zeotropic mixtures in low-temperature solar Rankine cycle*. Applied Energy, 2010. **87**(11): p. 3366-3373.

19. Walraven, D., B. Laenen, and W. D'haeseleer, *Comparison of thermodynamic cycles for power production from low-temperature geothermal heat sources*. Energy Conversion and Management, 2013. **66**(Supplement C): p. 220-233.
20. Yari, M. and S.M.S. Mahmoudi, *A thermodynamic study of waste heat recovery from GT-MHR using organic Rankine cycles*. Heat and Mass Transfer, 2011. **47**(2): p. 181-196.
21. Xu, R.-J. and Y.-L. He, *A vapor injector-based novel regenerative organic Rankine cycle*. Applied Thermal Engineering, 2011. **31**(6): p. 1238-1243.
22. *Supercritical CO2 Power Cycle Technology Development*. [cited 30.01.17]; Available from: <https://www.barber-nichols.com/case-studies/supercritical-co2-power-cycle-technology-development>.
23. Novotny, V. and M. Kolovratnik, *Absorption power cycles for low-temperature heat sources using aqueous salt solutions as working fluids*. International Journal of Energy Research, 2017. **41**(7): p. 952-975.
24. Ibrahim, O.M. and S.A. Klein, *Absorption power cycles*. Energy, 1996. **21**(1): p. 21-27.
25. KARTHÄUSER, J. and T. ÖSTRÖM, *Method for conversion of low temperature heat to electricity and cooling, and system therefore*. 2012, CLIMEON AB.
26. *Appendix C: The Stirling Engine*, in *Integration of Alternative Sources of Energy*. 2006, John Wiley & Sons, Inc. p. 438-446.
27. Group, T.L. *Natural Refrigerants*. 2017 [cited 30.10.17]; Available from: [http://www.linde-gas.com/en/products\\_and\\_supply/refrigerants/natural\\_refrigerants/index.html](http://www.linde-gas.com/en/products_and_supply/refrigerants/natural_refrigerants/index.html).
28. Council, I.C. *Flammable Refrigerants, The Evolving Impact on Codes*. [cited 30.10.17]; Available from: <http://media.iccsafe.org/Annual/2016/Flammable-Refrigerants-The-Evolving-Impact-on-Codes.pdf>.
29. Champier, D., *Thermoelectric generators: A review of applications*. Energy Conversion and Management, 2017. **140**(Supplement C): p. 167-181.
30. *Thermoelectric Generator Diagram*. [cited 30.11.17]; Available from: [https://en.wikipedia.org/wiki/File:Thermoelectric\\_Generator\\_Diagram.svg](https://en.wikipedia.org/wiki/File:Thermoelectric_Generator_Diagram.svg).
31. TNO. *Pure water and electricity with MemPower®*. [cited 2017 20.09]; Available from: <https://time.tno.nl/en/articles/pure-water-and-electricity-with-mempower/>.
32. Becquina, G. and S. Freund. *Comparative Performance of Advanced Power Cycles for Low-Temperature Heat Sources in ECOS 2012 The 25th international conference on efficiency, cost, optimization, simulation and environmental impact of energy systems*. 2012. Perugia, Italy.

## Appendix A Framework for evaluating heat-to-power technologies

The purpose of this section is to describe some general considerations and rules that shall apply in all technology evaluations and case studies involving surplus heat-to-power technologies. The intention of defining such a common framework is to enable better comparisons of technologies, from evaluations performed by different parties and over the centre duration. This is very much in line with the overall vision of HighEFF.

The framework parameters and KPI's defined below should always be included in HighEFF-evaluations, but the work does naturally not have to be limited to these constraints.

1. Evaluations are performed for a real or hypothetical *industrial scale implementations* with high potential impact. This implies a main focus on:
  - a. Considering significant heat sources from the investigated industry or industrial process
  - b. Concepts with significant utilization of the available energy in the heat source

2. The concept of *exergy* shall be the basis of a main KPI

- a. Exergy efficiency (fraction of net power produced to the available exergy in the heat source)
- b. For limited, sensible, and constrained heat sources, the available exergy is:

$$Exergy_{Sensible,Constr} = 1 - \frac{T_{Ambient}}{(T_{Heatsource} - T_{Constraint})} \cdot \ln\left(\frac{T_{Constraint}}{T_{Heatsource}}\right)$$

Where  $T_{Heatsource}$  is the initial temperature of the heat source, and  $T_{Constraint}$  is the minimum allowable temperature for the heat source (e.g. to maintain downstream process)

3. Energy and mass balances shall be fulfilled
4. *Sensible engineering practice* should be applied to all aspects that are not sufficiently modelled in both performance and cost. (Example: defining a reasonable temperature difference or pinch in a heat exchanger)
5. Fan/pump work (or penalties to), when applicable:
  - a. Pressure drop in Heat Exchangers
  - b. Cooling water pump (and similar) work: setting 1 bar nominal friction pressure loss if not modelled in detail. Use pump isentropic efficiency of 70% if not known.

$$W_{pump} = \eta_{pump} * \Delta P_{water} * V_{water}$$

$$W_{pump} = 0.7 * 1E6 Pa * V_{water}$$

- b. Fan work (or penalties to):

$$W_{fan} = \eta_{fan} * \Delta P_{fan} * V_{actual}$$