

Direct Methanol Fuel Cells (DMFCs)

DMFCs convert methanol directly into DC power, which makes them **more compact and simpler** than using a reformer with hydrogen cells; they also start up faster and do not involve high temperatures. Their applications are mainly **mobile power supplies and electronics**.



Methanol is an **excellent energy carrier**, with 30–40 times the energy density of Li-ion batteries and liquid in any environmental condition. The objective of this study is **integrating coolers and separators** in DMFC systems to make them even lighter and simpler, to quantify any negative implications for operation and efficiency, and to identify the appropriate application areas for the new integrated system.

The Fuel Cell Systems

Reference System

Each ancillary unit performs one task on one flow. Methanol is delivered to the cells in a **very weak solution** (1 M, only 3% by weight), to reduce parasitic reactions.

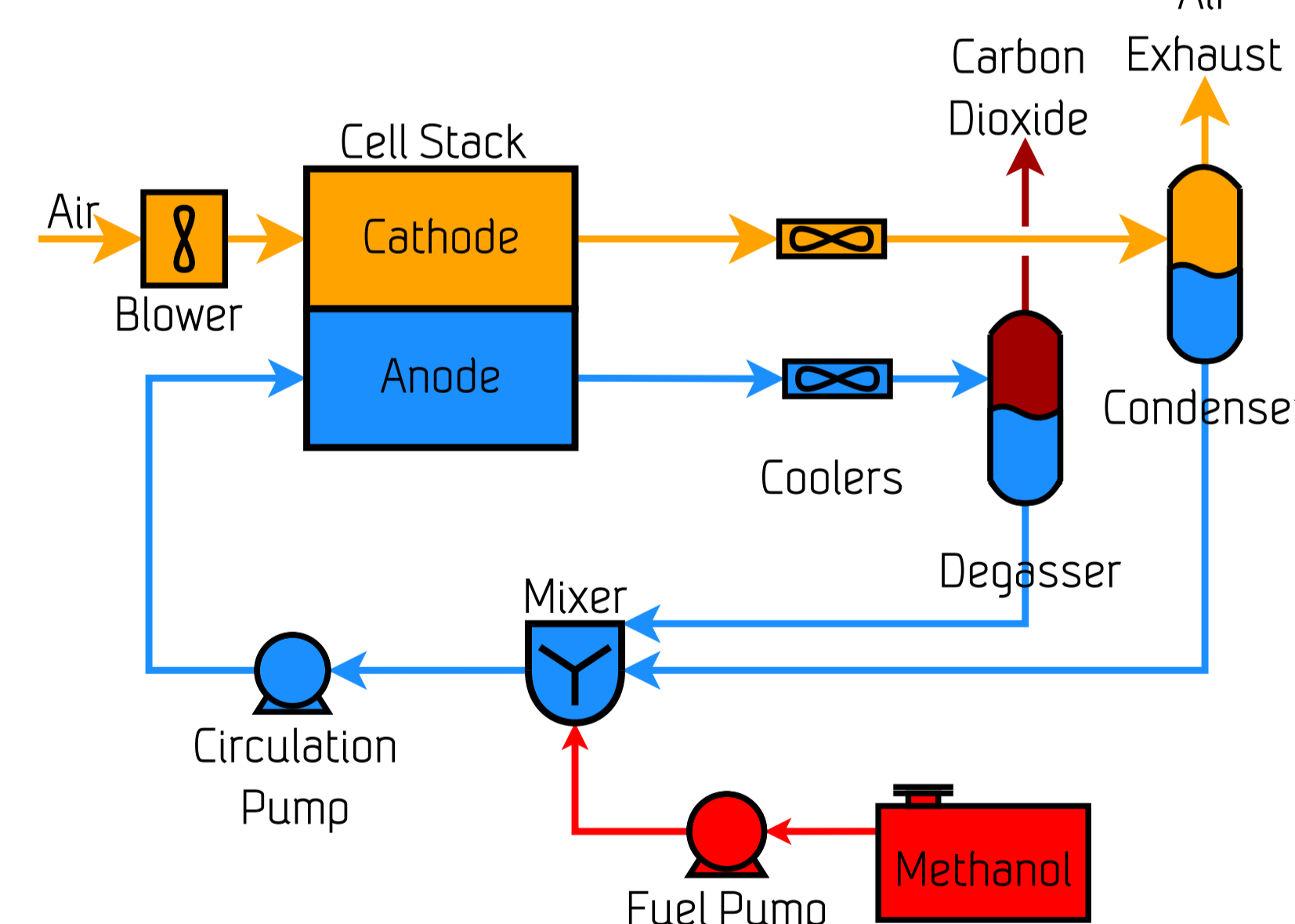

Integrated System

Two of the larger units, a separator and a cooler, are removed. Space and weight are saved for **more methanol**, storing more energy in the same size.

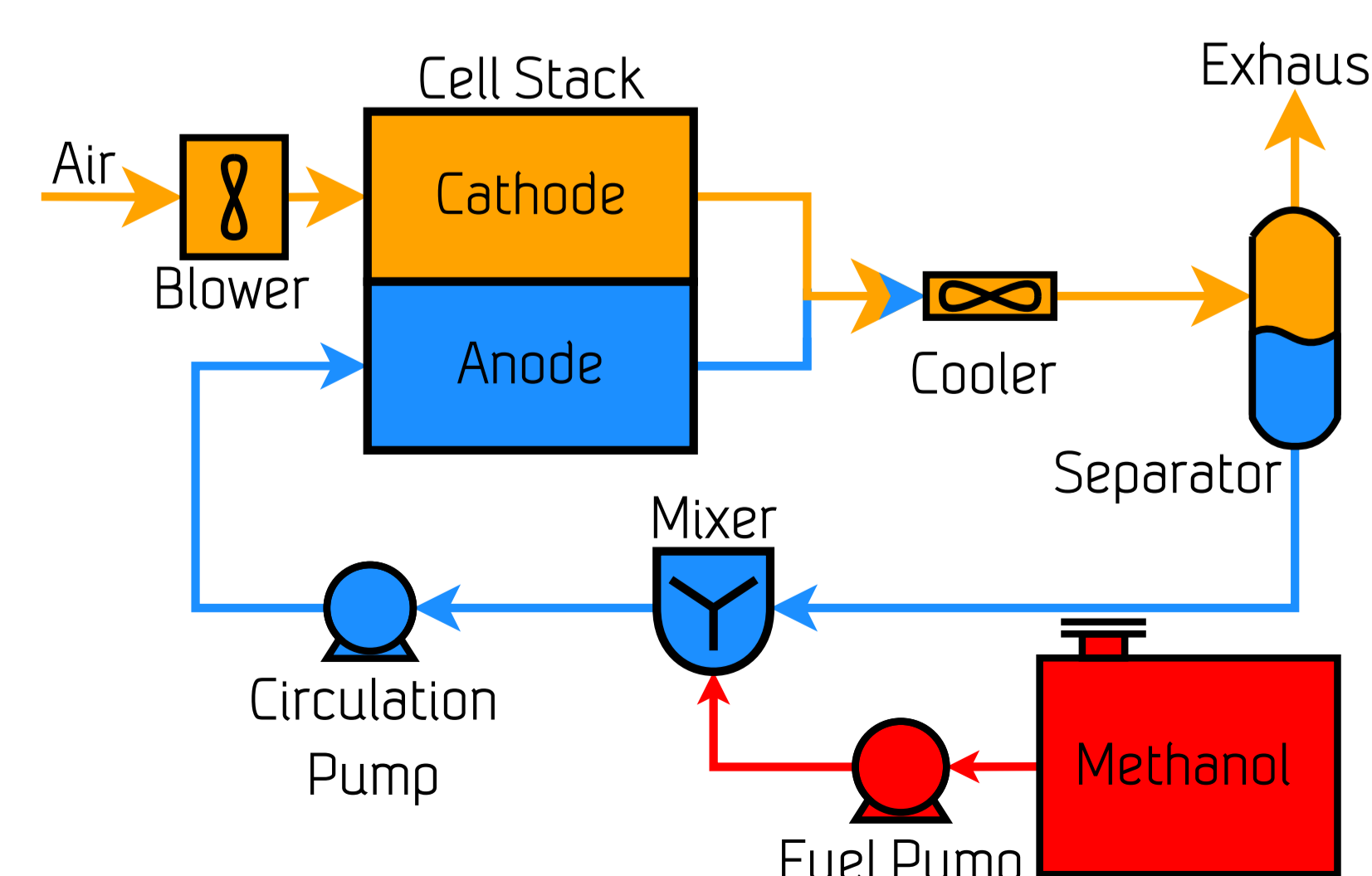

Control Strategy

Methanol concentration can be controlled without a dedicated measurement using the **methanol feed**. The **amount of solution** is regulated recovering water with the **air cooler**. In the reference system, stack temperature is feedback-controlled with the **solution cooler**. The integrated system has no **solution cooler** anymore, so stack temperature is controlled with the **circulation pump** (hybridly with λ control); also, **concentration control** must be adjusted to compensate for the increased loss of unreacted methanol in the separator.

Both control layouts enable stable and dynamically responsive operation, and removing one input variable does not degrade performance.

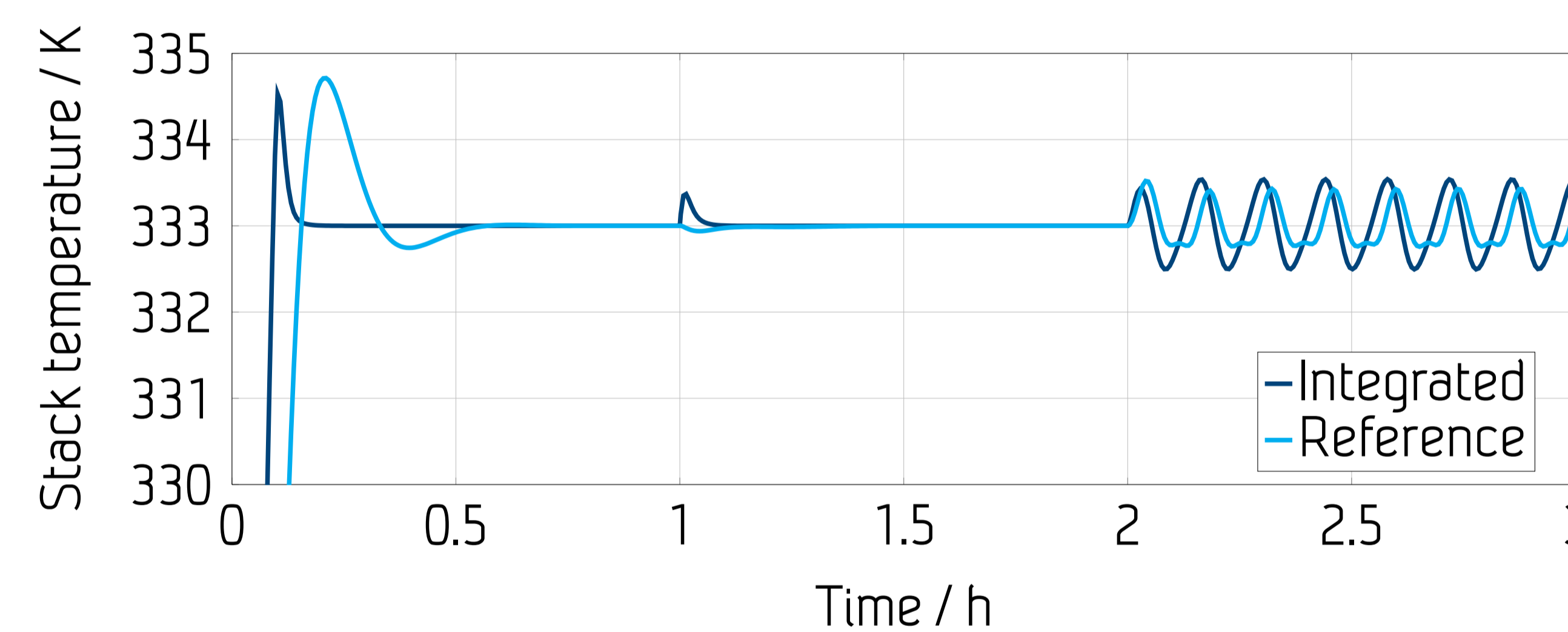

Integration of Heat Exchangers

Coolers are **sized** according to their maximum loads; these do in general *not* occur at the same operating conditions. The integrated cooler is sized according to the maximum *total* load, which may occur at yet another operating condition.

Theoretical considerations indicate that maximum cooling loads always occur at maximum design current and environmental temperature. There, at zero humidity, the total and **air** cooling loads are maximum; at 100% humidity, the **solution** cooling load is maximum.

As a result, the reference system's coolers are **oversized by about 25%** compared to the integrated system. This factor increases if higher **air excess ratios** or **lower methanol concentrations** are used.

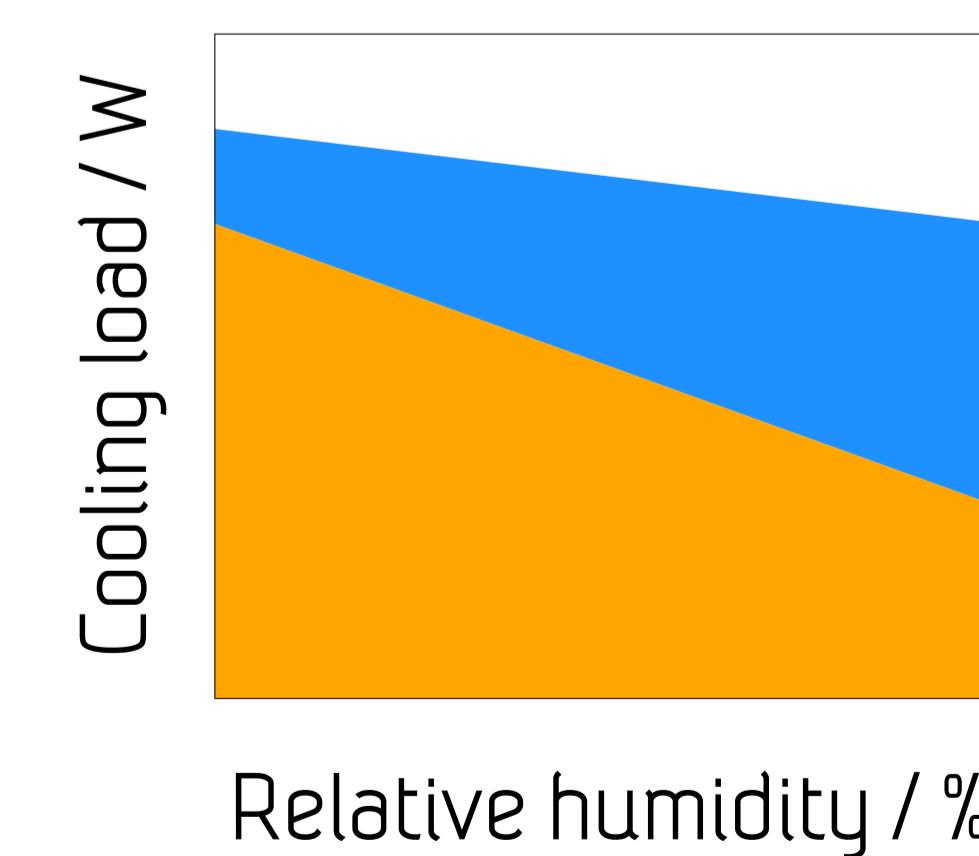

Methanol Loss

In the integrated system, the methanol solution is in contact with large amounts of air. **20–30 times more methanol is lost** as gas from the integrated system compared to the reference system.

This loss is equivalent to a **lower efficiency** in methanol conversion compared to the reference system. As shown below in a simulated dynamic test, the methanol loss for the reference system is negligible, but it is significant for the integrated system.

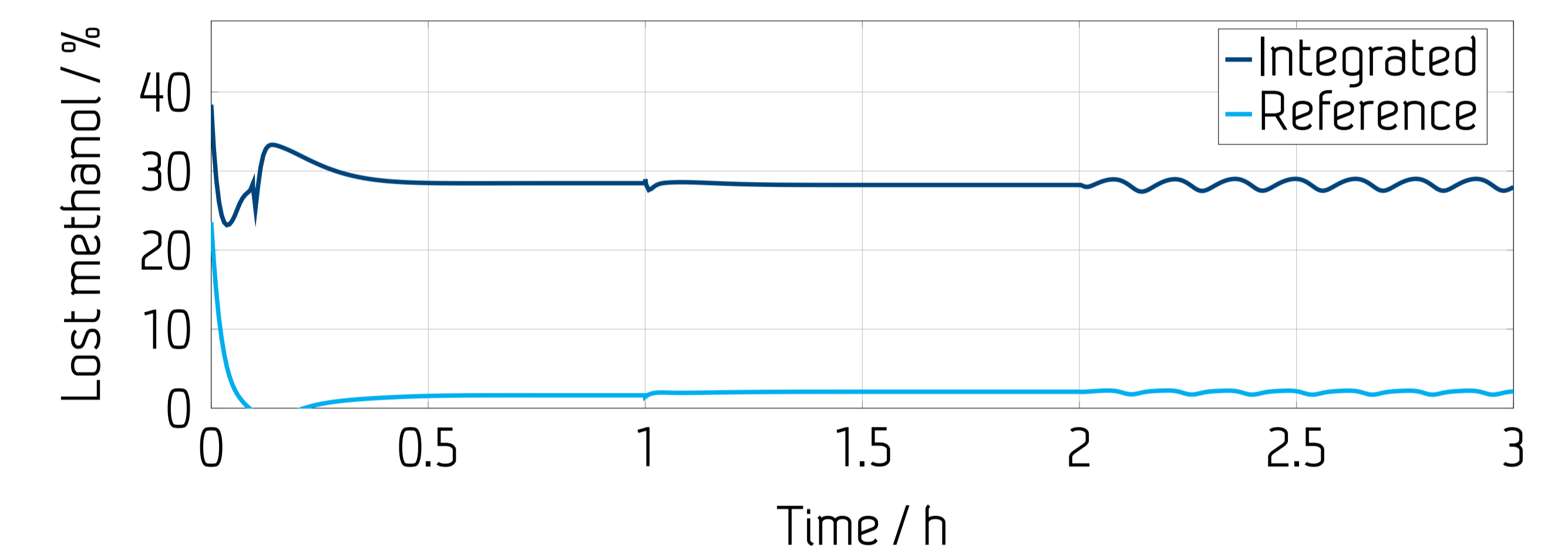

Also, methanol loss represents a **health hazard**: concentrations over 260 mg/m³ are considered unsafe for exposure. An integrated system providing power to a laptop computer in a 100 m³ room reaches this threshold in 3 hours.

Conclusion

The integrated DMFC system has a **lighter** methanol conversion plant, allowing more fuel to be stored; integration does not compromise controllability. However, fuel conversion **efficiency will be lower** by 20–30%, and methanol emissions make the system **unfit for indoor** operation.

The integrated design is appropriate for **low-power systems for outdoor usage**, for example portable communications systems with requirements on long autonomy and low weight, such as mountaineering equipment.



Publications in Journals

- Federico Zenith, Youngseung Na and Ulrike Krewer. *Effects of Process Integration in an Active Direct Methanol Fuel-Cell System*. In preparation.
- Federico Zenith, Maik Kraus and Ulrike Krewer. *Model-based analysis of ... for portable direct methanol fuel-cell systems*. Computers and Chemical Engineering, in review.
- Federico Zenith and Ulrike Krewer. *A simple and reliable model for estimation of methanol cross-over in direct methanol fuel cells and its application to methanol-concentration control*. Energy and Environmental Science, 4(2):519–527, 2011.
- Federico Zenith, Christine Weinzierl, and Ulrike Krewer. *Model-based analysis of the feasibility envelope for autonomous operation of a portable direct methanol fuel-cell system*. Chemical Engineering Science, 65(15):4411–4419, August 2010.
- Federico Zenith and Ulrike Krewer. *Modelling, dynamics and control of a portable DMFC system*. Journal of Process Control, 20(5):630–642, June 2010.