

SINTEF Building and Infrastructure Anja Birgitta Estensen Klausen

Steel fibres in load – carrying concrete structures. Guideline survey and practical examples

COIN Project report 17 - 2009



SINTEF Building and Infrastructure

Anja Birgitta Estensen Klausen

Steel fibres in load – carrying concrete structures Guideline survey and practical examples

COIN Project report 17 – 2009

COIN Project report no 17

Anja Birgitta Estensen Klausen

Steel fibres in load – carrying concrete structures

Guideline survey and practical examples

Keywords:

Materials technology, concrete, fibre

Photo, cover: Architekt, Jarmund Vignæs as arkitekter

ISSN 1891-1978 (online)

ISBN 978-82-536-1127-3 (pdf)

© Copyright SINTEF Building and Infrastructure 2009

The material in this publication is covered by the provisions of the Norwegian Copyright Act. Without any special agreement with SINTEF Building and Infrastructure, any copying and making available of the material is only allowed to the extent that this is permitted by law or allowed through an agreement with Kopinor, the Reproduction Rights Organisation for Norway. Any use contrary to legislation or an agreement may lead to a liability for damages and confiscation, and may be punished by fines or imprisonment.

Address: Forskningsveien 3 B
POBox 124 Blindern
N-0314 OSLO

Tel: +47 22 96 55 55

Fax: +47 22 69 94 38 and 22 96 55 08

www.sintef.no/byggforsk

www.coinweb.no

Cooperation partners / Consortium Concrete Innovation Centre (COIN)

Aker Solutions

Contact: Jan-Diederik Advocaat

Email: jan-diederik.advocaat@akersolutions.com

Tel: +47 67595050

NTNU

Contact: Terje Kanstad

Email: terje.kanstad@ntnu.no

Tel: +47 73594700

Spenncon AS

Contact: Ingrid Dahl Hovland

Email: ingrid.dahl.hovland@spenncon.no

Tel: +47 67573900

Borregaard Ligno Tech

Contact: Kåre Reknes

Email: kare.reknes@borregaard.com

Tel: +47 69118000

Rescon Mapei AS

Contact: Trond Hagerud

Email: trond.hagerud@resconmapei.no

Tel: +47 69972000

Norwegian Public Roads Administration

Contact: Kjersti K. Dunham

Email: kjersti.kvalheim.dunham@vegvesen.no

Tel: +47 22073940

mæxit Group AB

Contact: Geir Norden

Email: geir.norden@mæxit.no

Tel: +47 22887700

SINTEF Building and Infrastructure

Contact: Tor Arne Hammer

Email: tor.hammer@sintef.no

Tel: +47 73596856

Unicon AS

Contact: Stein Tosterud

Email: stto@unicon.no

Tel: +47 22309035

Norcem AS

Contact: Terje Rønning

Email: terje.ronning@norcem.no

Tel: +47 35572000

Skanska Norge AS

Contact: Sverre Smeplass

Email: sverre.smeplass@skanska.no

Tel: +47 40013660

Veidekke Entreprenør ASA

Contact: Christine Hauck

Email: christine.hauck@veidekke.no

Tel: +47 21055000

Preface

This study has been carried out within COIN - Concrete Innovation Centre - one of presently 14 Centres for Research based Innovation (CRI), which is an initiative by the Research Council of Norway. The main objective for the CRIs is to enhance the capability of the business sector to innovate by focusing on long-term research based on forging close alliances between research-intensive enterprises and prominent research groups.

The vision of COIN is creation of more attractive concrete buildings and constructions. Attractiveness implies aesthetics, functionality, sustainability, energy efficiency, indoor climate, industrialized construction, improved work environment, and cost efficiency during the whole service life. The primary goal is to fulfil this vision by bringing the development a major leap forward by more fundamental understanding of the mechanisms in order to develop advanced materials, efficient construction techniques and new design concepts combined with more environmentally friendly material production.

The corporate partners are leading multinational companies in the cement and building industry and the aim of COIN is to increase their value creation and strengthen their research activities in Norway. Our over-all ambition is to establish COIN as the display window for concrete innovation in Europe.

About 25 researchers from SINTEF (host), the Norwegian University of Science and Technology - NTNU (research partner) and industry partners, 15 - 20 PhD-students, 5 - 10 MSc-students every year and a number of international guest researchers, work on presently 5 projects:

- Advanced cementing materials and admixtures
- Improved construction techniques
- Innovative construction concepts
- Operational service life design
- Energy efficiency and comfort of concrete structures

COIN has presently a budget of NOK 200 mill over 8 years (from 2007), and is financed by the Research Council of Norway (approx. 40 %), industrial partners (approx 45 %) and by SINTEF Building and Infrastructure and NTNU (in all approx 15 %).

For more information, see www.coinweb.no

Tor Arne Hammer
Centre Manager

Summary

The main objective of this report is to identify the current state of the art within design of steel fibre reinforced concrete (SFRC) in Europe. The report contains a short overview of the theoretical background of SFRC in the form of a guideline survey, followed by practical examples demonstrating the design of a concrete structure with conventional bar reinforcement, compared with partly and total fibre reinforcement of the various structure elements. The structural elements included in the practical examples are foundations, walls, columns and slabs. Calculations due to deflections and cracking are omitted due to the present lack of calculation methods.

In the guideline survey, the following design guidelines are included;

- Norwegian preliminary guideline for steel fibre reinforced concrete (NPG for SFRC), Several contributors, Norway, 2006.
- Guidance for the Design of Steel-Fibre-Reinforced Concrete (GD of SFRC), Concrete Society, UK, 2007.
- Test and design methods for steel fibre reinforced concrete. σ - ϵ design method. Final Recommendation, RILEM TC 162-TDF, 2003.

According to both RILEM and GD of SFRC, the residual flexural strength of SFRC is to be determined experimentally. The NPG, on the other hand, opens for theoretical calculations to determine the residual flexural strength. The preferable method for comparing the above mentioned guidelines would be to perform a design of a given 'beam in bending'-situation for each of the different guidelines, leading to accurate comparable results. This is however complicated due to the requirement for an experimental determination of the residual flexural strength in RILEM and GD of SFRC.

The design of the different structural elements in the practical examples shows that adding steel fibre to concrete has a favourable effect on the concrete's moment capacity. For structural parts with a limited variation in moment and shear forces, fibre reinforcement is competitive. For e.g. flat slabs, with large moment and shear gradients, a relatively large dosage of steel fibre is required to totally avoid conventional bar reinforcement. With respect to the shear capacity, adding steel fibre to the concrete has a very favourable effect. Hence, it can be propitious to use a combination of steel fibre reinforcement and bar reinforcement, where the steel fibres carry shear forces and parts of the moment. Consequently, adding 1 vol.-% steel fibre to concrete does have a significant effect on the concrete's capacity, and a combination of bars and fibres is the most realistic approach.

For a more thorough comparison of the guidelines in question, appurtenant prescribed bending test ought to be performed. With that, calculations for a given 'beam in bending'-situation can be performed for each of the different guidelines, leading to accurate comparable results. Incorporating design by additional guidelines for comparison should be considered. In addition, design with more focus on SLS should be performed, i.e. where even effects due to deflections and cracking are considered.

An evaluation of steel fibre reinforcement versus conventional bar reinforcement with respect to building costs would be of big relevance due to future use of steel fibre reinforcement.

Table of contents

PREFACE	3
SUMMARY	4
TABLE OF CONTENTS	5
1 SUMMARY AND CONCLUSIONS	7
1.1 GUIDELINE SURVEY	7
1.2 EXAMPLE	7
1.3 FURTHER WORK	8
2 INTRODUCTION	9
2.1 BACKGROUND	9
2.2 OBJECTIVES	9
3 DESIGN CRITERIA	10
3.1 FIBRE BEHAVIOUR	10
3.2 NORWEGIAN PRELIMINARY GUIDELINES	12
3.2.1 <i>General</i>	12
3.2.2 <i>Material qualities</i>	13
3.2.3 <i>Ultimate Limit State (ULS)</i>	14
3.2.4 <i>Serviceability Limit State (SLS)</i>	16
3.3 GUIDANCE FOR THE DESIGN OF STEEL-FIBRE-REINFORCED CONCRETE - UK	18
3.3.1 <i>General</i>	18
3.3.2 <i>Material qualities</i>	18
3.3.3 <i>Ultimate Limit State (ULS)</i>	20
3.3.4 <i>Serviceability Limit State (SLS)</i>	23
3.4 RILEM	24
3.4.1 <i>General</i>	24
3.4.2 <i>Material qualities</i>	24
3.4.3 <i>Ultimate Limit State (ULS)</i>	25
3.4.4 <i>Serviceability Limit State (SLS)</i>	27
3.5 GUIDELINE COMPARISON	28
4 CONSEQUENCES ON A CONCRETE BUILDING	30
4.1 DESIGN PREMISES	30
4.1.1 <i>General</i>	30
4.1.2 <i>Geometry</i>	30
4.1.3 <i>Materials</i>	30
4.1.4 <i>Load and dimensions</i>	31
4.2 TRADITIONAL DESIGN	36
4.2.1 <i>Foundations</i>	36
4.2.2 <i>Walls</i>	37
4.2.3 <i>Columns</i>	38
4.2.4 <i>Slabs</i>	38
4.3 DESIGN AND CONSTRUCTION WITH A MANAGEABLE FIBRE CONTENT	39
4.3.1 <i>General</i>	39
4.3.2 <i>Foundations</i>	39
4.3.3 <i>Walls</i>	40
4.3.4 <i>Columns</i>	40
4.3.5 <i>Slabs</i>	41
4.4 DESIGN AND CONSTRUCTION WITH FIBRES AS SOLE REINFORCEMENT	41
4.4.1 <i>Foundations</i>	41
4.4.2 <i>Walls</i>	42
4.4.3 <i>Columns</i>	42
4.4.4 <i>Slabs</i>	43

4.5	COMPARISON.....	44
4.5.1	<i>Foundations</i>	44
4.5.2	<i>Walls</i>	45
4.5.3	<i>Columns</i>	45
4.5.4	<i>Slabs</i>	46
REFERENCES		47
APPENDIX		48
APPENDIX A,	THEORETICAL MODEL FOR FIBRE ORIENTATION	
APPENDIX B,	MINIMUM REQUIRED REINFORCEMENT	
APPENDIX C,	CALCULATIONS – TRADITIONAL DESIGN	
APPENDIX D,	CALCULATIONS – MANAGEABLE FIBRE CONTENT	
APPENDIX E,	CALCULATIONS – SOLE FIBRE REINFORCEMENT	
APPENDIX F,	CALCULATIONS – DESIGN MOMENT, SLAB	

1 Summary and conclusions

1.1 Guideline survey

In this guideline survey, the following design guidelines have been included;

- Norwegian preliminary guideline for steel fibre reinforced concrete (NPG for SFRC) [Several contributors, 2006]
- Guidance for the Design of Steel-Fibre-Reinforced Concrete (GD of SFRC) [Concrete society, 2007]
- Test and design methods for steel fibre reinforced concrete. σ - ϵ design method. Final Recommendation [RILEM TC 162-TDF, 2003]

The GD of SFRC defines an upper volume percent of fibre, approximately 80 kg/m³, in its scope of work. In the NPG and RILEM, on the other hand, no such upper limit seems to be defined.

NPG for SFRC states that steel fibre can be used as sole reinforcement only for structures with safety level 1. Structures with safety level 2 or higher are to have conventional bar reinforcement to transfer all external forces in addition to the fibre reinforcement.

In the GD of SFRC the design ultimate moment of resistance M_p is, among other factors, dependent on the design compressive strength of concrete f_{cd} . In the NPG, the design compressive strength of concrete f_{cd} is not included in the calculations of the design ultimate moment of resistance unless the residual stress $f_{tk,res}$ exceeds 2.5 N/mm².

While the NPG for SFRC and DG of SFRC contains specific expressions describing the design ultimate moment of resistance, RILEM describes a stress-strain diagram, providing a basis for derivation of the ultimate moment of resistance.

According to both RILEM and GD of SFRC, the residual flexural strength of SFRC is to be determined experimentally. The NPG, on the other hand, opens for theoretical calculations to determine the residual flexural strength, possible combined with fibre pull-out tests. The preferable method for comparing the previous mentioned guidelines would be to perform a design of a given 'beam in bending'-situation for each of the different guidelines, leading to accurate comparable results. This is however complicated due to the previous mentioned requirement for an experimentally determination of the residual flexural strength in RILEM and the GD of SFRC.

1.2 Example

Adding steel fibre to concrete has a favourable effect on the concrete's capacity. However, the design results show that a relatively large dosage of steel fibre is required to totally avoid conventional bar reinforcement in the different structural parts. For the current structure and load situation, when conventional reinforcement is omitted, the basement wall is found to be the structure part with the least required volume content steel fibre. Although in this report a content of 1 vol.-% steel fibre is said to be a manageable steel fibre content, the literature indicates that the critical steel fibre content is 2-4 vol.-%. It is found that the design and construction of the current wall with steel fibre as sole reinforcement requires a steel fibre content equal to 1.3 vol.-%, i.e. within the limits of acceptance. Consequently, for the current example, the walls are the structure parts most likely to be constructed with steel fibre as sole reinforcement. For comparison, with steel fibre as sole reinforcement, the

required steel fibre content for foundations and slabs are 2.4 vol.-% and 5.2 vol.-% respectively.

The design and construction of the current flat slab with fibres as sole reinforcement requires a steel fibre content equal to as much as 5.2 vol.-%. The moment distribution over a slab consists of concentrated peaks over the bearing points. These concentrated moment peaks are much higher than the field moments. Steel fibre reinforcement is evenly distributed throughout the slab. Consequently, when using steel fibre as sole reinforcement, the whole slab is reinforced due to the concentrated and limited moment peaks over the bearing points. As a result, a very high dosage of steel fibre is required, and thus most of the slab is provided with much more reinforcement than required. Consequently, the design and construction of a slab with steel fibres as sole reinforcement seems to be ineffective with respect to costs and manageability of the concrete.

With respect to the shear capacity, adding steel fibre to the concrete has a very favourable effect. By adding 1 vol.-% steel fibre, the shear reinforcement requirement for the current foundation, at its critical section d , is reduced from 2396 mm² to 0 mm². Hence, for foundations and slabs it can be propitious to use a combination of steel fibre reinforcement and bar reinforcement, where the steel fibres carry shear forces and parts of the moment.

By adding 1 vol.-% steel fibre to the concrete, the required bar reinforcement for the columns is reduced with 84 %. The main reason for this considerable reinforcement reduction is that the NPG for SFRC [Several contributors, 2006] has no requirements for minimum reinforcement when it comes to steel fibre reinforced columns. On the other hand, design and construction of the column in question with fibres as sole reinforcement is not possible due to the large axial compression forces. A possible approach is to increase the column dimensions and let the concrete carry the compression forces.

Consequently, adding 1 vol.-% steel fibre to concrete does have a significant effect on the concrete's capacity, and a combination of bars and fibres is the most realistic approach. At the same time, with a combination of bars and fibres, more attention should be given to the execution, as reinforcement bars tend to act as obstacles, preventing the fibres from an even distribution.

1.3 Further work

For a more thorough comparison of the guidelines in question, appurtenant prescribed bending tests ought to be performed. With that, calculations for a given 'beam in bending'-situation can be performed for each of the different guidelines, leading to accurate comparable results. Incorporating design by additional guidelines for comparison should also be considered. Further, design rules in SLS should be improved, allowing effects due to deflections and cracking to be considered.

An evaluation of steel fibre reinforcement versus conventional bar reinforcement with respect to building costs would also be of big relevance due to future use of steel fibre reinforcement.

When considering a combination of bars and fibres, further investigations should be performed with respect to the casting performance and fibre distribution, as reinforcement bars tend to act as obstacles, preventing the fibres from an even distribution.

2 Introduction

2.1 Background

Concrete is strong in compression, but has a low tensile strength. In structural applications, this is overcome by providing steel reinforcing bars to carry the tensile forces once the concrete has cracked, or by prestressing the concrete so that it remains largely in compression when subjected to loading.

As an alternative to conventional steel bar reinforcement, steel fibres can be mixed into the concrete. When subjected to external loading, micro cracks start forming in the concrete. The initial cracks will then start to grow, and eventually lead to a macro crack covering several micro cracks. Fibres bridging over the cracks lead to increased shear, moment and punching resistance, increased dowel effect, reduced crack spacing and crack widths, increased flexural stiffness and increased ductility in compression [Døssland, 2008].

The use of fibre reinforcement instead of conventional bar reinforcement causes improved efficiency and working conditions on construction sites and in the prefabrication industry. The reduced handling of reinforcement bars on the construction site will cause health and safety benefits, as well as it meets the problem of future shortage of skilled workers. The reduced labour, when replacing conventional bar reinforcement with fibre reinforcement, can in some cases compensate the increased material costs. Another benefit of fibre reinforcement is the avoidance of problems caused by misplacement of conventional steel in the depth of the slab, leading e.g. to reduced strength or low concrete cover causing decreased durability.

Fibre reinforcement in combination with self compacting concrete (SCC) has shown to further improve the structural strength as well as the working conditions during production, as compared with vibrator compacted concrete (VCC).

The use of fibre reinforcement for structural applications is in Norway mainly limited to slabs on ground and sprayed concrete for rock support. The main reasons for this limited use of fibre reinforced concrete seem to be; the lack of accepted guidelines, the challenge of achieving the desired fibre distribution during casting, as well as the limited experience with the use of steel fibre reinforced concrete.

Norwegian preliminary guideline for steel fibre reinforced concrete (NPG for SFRC) [Several contributors, 2006] encourages limited use of fibre reinforced concrete, which will help gain experience and form the basis of further development.

2.2 Objectives

The main objective of this report is to identify the current state of the art within design of steel fibre reinforced concrete (SFRC).

The report contains a short overview of the theoretical background of SFRC, followed by practical examples demonstrating the design of a concrete structure with conventional bar reinforcement, compared with partly and total fibre reinforcement of the given concrete structure.

3 Design criteria

3.1 Fibre behaviour

Steel fibres, being randomly distributed in the concrete, intercept micro-cracks as they form, and hence inhibit the tendency for the micro-cracks to form into larger cracks. After cracking, the fibres spanning the crack will provide a degree of residual load-carrying capacity, defined as the residual strength of the SFRC. The concrete's residual load-carrying capacity can be considerable, depending on the dosage and the type of fibres used, and can be used in plastic design approaches, Guidance for the Design of Steel-Fibre-Reinforced Concrete (GD of SFRC) [Concrete society, 2007].

A wide range of fibres exist. Fibres made from steel, plastic, glass and natural materials are available in a variety of shapes, sizes and thicknesses. A selection of steel fibres with different shapes and sizes are shown in *Figure 3.1*.

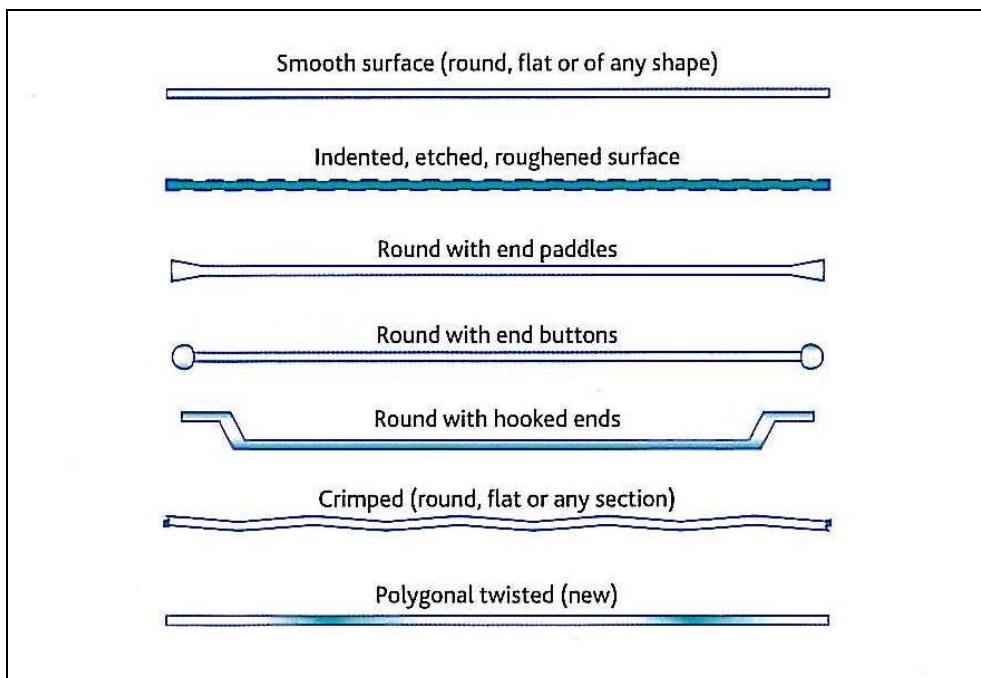

Figure 3.1: Types of steel fibre [Concrete society, 2007].

The main factors that control the performance of the composite material are physical properties of fibres and matrix, and the strength of bond between fibres and matrix [Vikan, 2007]. According to GD of SFRC [Concrete society, 2007], the physical properties of fibres which are considered to have the strongest influence on the performance of a steel fibre in concrete are:

- Bond and anchorage mechanism
- Fibre length and diameter
- Dosage (kg/m^3)
- Fibre count (number of fibres per kg of fibre)
- Tensile strength
- Elastic modulus

The amount of fibres added to a concrete mix is measured as a percentage of the total volume of the composite (concrete and fibres), termed volume fraction, V_f . The aspect ratio, l/d_f , is calculated by dividing fibre length, l , by its diameter, d . Fibres with a non-circular

cross section use an equivalent diameter when calculating the aspect ratio. Steel fibres are short, discrete lengths of steel with an aspect ratio from about 20 to 100. The fibre length varies, in general, from 13 mm to 64 mm. The most common fibre diameters are in the range of 0.45 mm to 1 mm. The usual amount of steel fibres is from 0.25 vol.-% (20 kg/m³) to 2 vol.-% (157 kg/m³). Volumes of more than 2 % steel fibres generally reduce workability and fibre dispersion and require special mix design or concrete placement techniques [Vikan, 2007].

To improve the ability to transfer forces between concrete and steel fibres, a high aspect ratio is desired. However, there is a limit, and very slender fibres with aspect ratio, $l_f/d_f > 100$ tend to cling together in balls, thus reducing workability and possibly also reducing the mechanical properties of the hardened steel fibre reinforced concrete, the latter due to an uneven dispersion of fibres. To improve the bond, steel fibres are nowadays manufactured in a number of different shape and types [Jansson, 2008].

The tensile strength of the steel fibre may be in the range 200-2600 MPa and ultimate elongations between 0.5 and 5 %. The elastic modulus is around 200 GPa, thus greatly exceeding the elastic modulus of the concrete [Jansson, 2008].

After cracking, the fibres transmit tensile forces over the crack into the surrounding concrete. To avoid brittle failure, fibre pull-out has to be the dominating mechanism. Hence, it is important that the yield capacity of the fibre is sufficient so that fibre rupture is avoided. Fibre rupture, causing a brittle breakage, is not desirable. The possibility for fibre rupture depends mainly on the fibre strength, matrix strength, embedment length, fibre geometry and the inclination angle to the crack plane [Døssland, 2008].

The post-crack tensile strength of fibre reinforced concrete (FRC) is very much dependent on the distribution and orientation of fibres, which again is governed by the casting process, the concrete mix, the size and geometry of the specimen, its boundaries and potential obstacles like reinforcement bars [Døssland, 2008]. Poorly dispersed fibres provide little or no reinforcement in some regions, which then act as flaws in the composite material. Controlling fibre dispersion characteristics is generally difficult and new methods are required [Vikan, 2007].

The composition and workability of the concrete affects the orientation and distributions of fibres. For SCC, the fibre orientation depends strongly on the flow of the concrete during casting, whereas the vibration is the main influence factor with VCC. The use of immersion vibrator for compaction is not recommended since the fibres disperse where the vibrator is placed into the concrete, which can cause weakness zones where almost no fibres are present [Døssland, 2008].

According to the test method proposed in the NPG for SFRC [Several contributors, 2006], the fibre orientation factor can be estimated by counting fibres on a sawn block taken near the cracked section of a beam exposed to 4-point bending [Døssland, 2008]. Another approach suggested, is to count the fibres on three sections perpendicular to each other to estimate the fibre volume [Døssland, 2008]. The latter approach is based on an assumption that all fibre orientations can be described as a combination between three ideal orientation situations, *Figure 3.2*. In this report, the theoretical model for fibre orientation according to [Thorenfeldt, 2003] is used. The theoretical model is derived in *Appendix A*, and the results are described below.

The section ratio, ρ , of a concrete cross-section is defined as the area of fibres per unit concrete area, $\rho = n \cdot A_f / L^2$, where n is numbers of fibres in the concrete section, A_f is the cross-section of a singular fibre and L^2 is the concrete cross-section area. If the fibre orientation is isotropic, the section ratio in each direction is $\rho_1 = \rho_2 = \rho_3 = \rho / 2$, with a

corresponding plastic normal force resultant per unit concrete area equal to $F_{xp}/A_c = v_f \cdot \sigma_f/3$, where $v_f = V_f/V_c$ is the fibre volume ratio, F_{xp} is the plastic normal force resultant in the given direction, A_c is the cross-section of the concrete in the given direction, and σ_f is the stress in the steel fibres. If fibres are horizontally orientated in plane 1-2, the section ratio in the two directions will be $\rho_1 = \rho_2 = (2/\pi) \cdot v_f = 0.64 v_f$ ($\rho_3 = 0$) with a corresponding plastic normal force resultant per unit concrete area equal to $F_{xp2}/A_c = v_f \cdot \sigma_f/2$. If all fibres are uniformly directed, the share of fibres in this direction would be $\rho_1 = v_f$ ($\rho_2 = \rho_3 = 0$), with a corresponding plastic normal force resultant per unit concrete area equal to $F_{xp1}/A_c = v_f \cdot \sigma_f$.

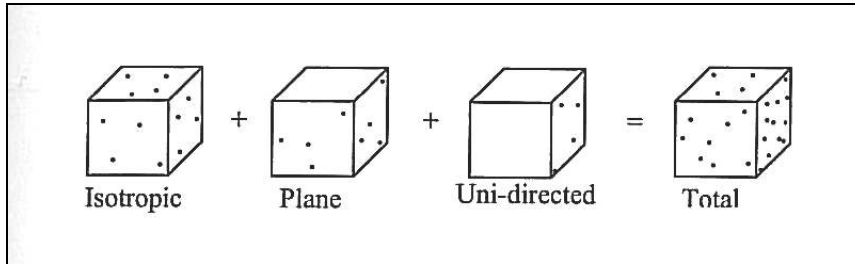

Figure 3.2: Share of fibres in each direction [Døssland, 2008].

Fibres tend to orientate parallel to the boundaries, inducing an orientation which is increasingly two-dimensional with decreasing thickness of the element [Døssland, 2008].

Tests made by [Døssland, 2008] found that SCC is to be preferred over VCC. SCC showed a more uniform fibre distribution as well as a higher average residual stress in the fibres than for VCC.

3.2 Norwegian preliminary guidelines

3.2.1 General

Due to the Norwegian lack of accepted guidelines treating FRC, a Norwegian preliminary guideline (NPG), based on a 3 year research and development project “Stålfiberarmering i betong” (“Steel fibre reinforced concrete”), was composed. The guideline was meant to act as a supplement to the Norwegian design codes NS 3473, NS-EN 206-1 with national addendum, and NS3465. The NPG encourages limited use of FRC, which will help gain experience and form the basis of further development.

Typical constructional elements covered by the NPG are foundations, walls, plates and shells, slabs, pipes, culverts and beams. The guideline can also be used for ground-supported slabs and sprayed concrete (shotcrete).

Execution and control are essential factors when utilizing steel fibres as concrete reinforcement. Mixing, transport and casting of steel fibre reinforced concrete demand extended control in accordance with NS3465, and in addition, the NPG has established supplementary requirements in its chapter 11 and 12. It is important to protect oneself from serious mistakes, e.g. cold joints leading to no fibres bridging a plane in the structure. The supplier of fibres has to document the pull-out resistance of the fibres for the concrete in question.

Because of the limited experience with FRC, the NPG demands all structures with safety level 2 or higher to have conventional bars to transfer all external forces in addition to the fibres.

3.2.2 Material qualities

SFRC is classified by its compressive strength in the same manner as for plain concrete, based on an assumption that the compressive and tensile strength ratio is the same. In addition, SFRC is classified due to its residual flexural strength.

The residual stress of SFRC is given by;

$$f_{tk, res} = \eta_0 v_f \eta_1 \sigma_{fk, max} = \eta_0 v_f \sigma_{fk, mid} \quad (\text{Eq. 3-1})$$

where	v_f	Fibre volume ratio = V_f/V_c = (fibre volume)/(concrete volume)
	$\sigma_{fk, max}$	Maximum stress of fibre with anchorage length $l_b = l_f/2$ at a crack, decided by bond and upper yield limit
	$\sigma_{fk, mid}$	Average stress in all fibres bridging a crack, with random embedded length and orientation
	η_1	Aspect ratio, $\sigma_{fk, mid} / \sigma_{fk, max}$, can be set to approximately 0.5 for fibres with a constant adhesion between fibre and matrix, and will normally be higher for fibres with end hooks
	η_0	Relationship between the resultant force of fibres with a randomly distributed direction and the resultant force of uniform directional fibres with the same stress

η_0 is a capacity factor which indicates how much of the fibre forces that are effective normal to the crack plane. The capacity factor η_0 can be assumed to be 1/3 for concrete with a randomly 3D distribution and orientation of fibres, 1/2 for fibres in planes parallel to tension direction, and 1.0 for uniform directional fibres, *Appendix A*.

(Eq. 3-1) describes the residual stress of SFRC based on the assumption that steel fibres crossing a concrete crack contributes to the tension capacity of the reinforced concrete in the same way as for reinforcement bars. The steel fibres contribute force only in their direction, and there is no main change of direction of the fibre at the crack. It is also assumed that maximum force in a steel fibre at a crack is defined by the fibre's anchorage capacity, and that it is virtually independent of the fibre direction in proportion to the crack normal. Typical tension behaviour for SFRC is shown in *Figure 3.3*.

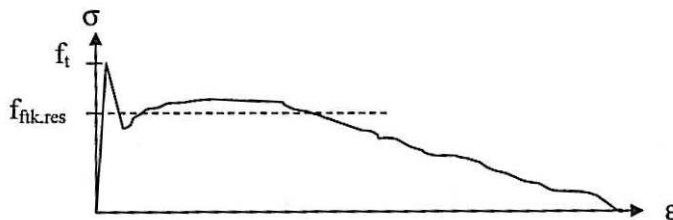

Figure 3.3: Typical tension behaviour for SFRC [Døssland, 2008]

3.2.3 Ultimate Limit State (ULS)

3.2.3.1 Material safety factor

The material partial safety factor for the residual strength of FRC, $f_{tk,res}$, is given as;

$$\gamma_m = 1.55$$

3.2.3.2 Bending

The load carrying capacity of SFRC is dimension dependent, and consequently a scale factor is required;

$$p = 1.1 - 0.7h > 0.75 \quad (\text{Eq. 3-2})$$

where h is the depth of the beam [m].

For self-compacting concrete elements, the residual strength can be scaled with a yield factor e .

In upper parts of the element; $e=0.9$

In lower parts of the element; $e=1.2$

If the residual strength is determined by bending tests of beams made of SCC, the yield factor should be set to $e=1.0$.

Concrete reinforced with steel fibre only

The moment capacity of SFRC is derived from a consideration of equilibrium of forces over the concrete cross-section, as well as the assumption that the residual stress is working over an area $0.8h$ of the cross-section, with an inner level arm equal to $0.5h$, *Figure 3.4*.

$$\begin{aligned} M_{fd} &= (0.8h \cdot f_{fd,res} \cdot p \cdot e) \cdot b \cdot 0.5h \\ M_{fd} &= 0.4 f_{fd,res} b h^2 p e \end{aligned} \quad (\text{Eq. 3-3})$$

where $f_{fd,res} = f_{tk,res}/\gamma_m$, b is the section width of the beam, while the other factors are defined in the chapters above.

For SFRC with a residual stress $f_{tk,res}$ larger than 2.5 N/mm^2 , the cross-section's compression zone height must be determined. The cross-section's compression zone height can be found by considering axial equilibrium with a stress block f_{cd} in the compression zone.

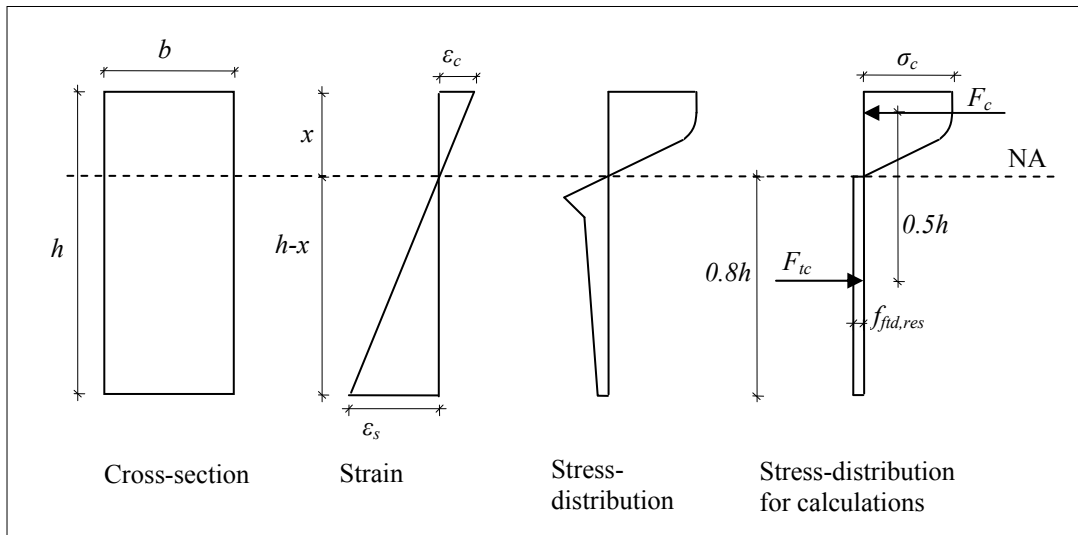

Figure 3.4: Strain and stress distribution over a SFRC cross-section.

Concrete reinforced with both steel fibre and reinforcement bars

For concrete reinforced with reinforcement bars as well as steel fibres, the moment capacity is to be determined as follows;

- the working diagram for the conventional reinforcement is assumed to follow the guidelines given in NS3473:2003 11.3, but with a maximum strain $< 2.5\%$.
- The compression zone of the concrete cross-section is to be characterized due to the guidelines given by NS3473:2003 11.3
- When calculating the capacity due to steel fibres, the concrete's compression zone height is to be equal or higher than the compression zone height when calculating capacity with conventional reinforcement only

For a fibre reinforced concrete structure with safety level 2 or higher, all parts of the structure have got to have conventional steel bars sufficient to carry all external forces. When calculating required amount of conventional steel bars, all material safety factors can be set to $\gamma_m = 1.0$.

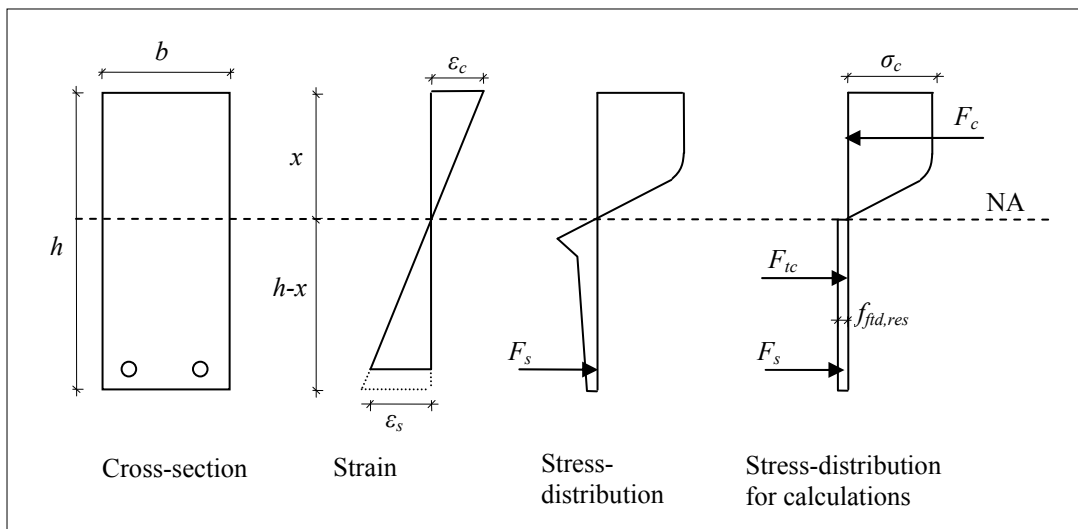

Figure 3.5: Strain and stress distribution over a cross-section reinforced with both steel fibres and reinforcement bars.

When cross-sections reinforced with both bars and steel fibres are subjected to a combination of bending and axial forces, the design is performed due to a M-N diagram.

3.2.3.3 Shear

Steel fibres increase the concrete's shear strength with a contribution V_{fd} .

$$V_d = V_{cd} + V_{fd} + V_{sd} \quad (\text{Eq. 3-4})$$

where V_{cd} is the shear strength of the concrete
 V_{fd} is shear strength because of the steel fibres
 V_{sd} is shear strength because of conventional reinforcement

The steel fibre's contribution to the shear strength is in the NPG for SFRC [Several distributors, 2006] given by;

$$V_{fd} = 0.8 \cdot f_{fd, res} bdp \quad (\text{Eq. 3-5})$$

(Eq. 3-5) can be derived from the shear capacity contribution stated in the Norwegian Standard code NS3473 [NS3473 Norges Standardiseringsråd, 2003];

$$V_{sd} = \frac{f_{sd} \cdot A_{sv}}{s} \cdot z \cdot (\cot \theta + \cot \alpha) \cdot \sin \alpha \quad (\text{Eq. 3-6})$$

when replacing the reinforcement bars in V_{sd} with steel fibres, assuming $z = 0.8d$, cracking angle 45° , $\alpha = \pi/2 - \theta$, and isotropic oriented fibres, i.e. that the force component normal to any section is $v_f \cdot \sigma_f / 3$ (Chapter 3.1 Fibre behaviour), Figure 3.6.

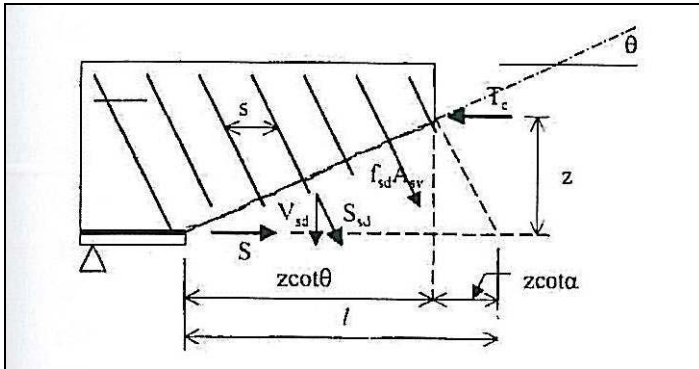

Figure 3.6: Beam with stirrups [Døssland, 2008].

3.2.4 Serviceability Limit State (SLS)

3.2.4.1 Minimum reinforcement

Calculations of the required minimum amount of reinforcement are based on the assumption that the tension-zone of a cross-section should have the same capacity after cracking as immediately before cracking.

In the NPG for SFRC, [Several distributors, 2006], demands defining the minimum amount of reinforcement bars required in special parts of the structure is given. Structural elements included in these minimum required reinforcement definitions are plates, slabs, beams, columns, walls and shells, foundations and structures exposed to torsion. The practical examples in this report include foundations, walls, columns and slabs, hence minimum amounts of reinforcement required for these structural parts, as defined in the NPG, are given below.

When the equations defined below result in a minimum reinforcement equal to zero or less, no reinforcement bars are required, and further control of crack widths can be omitted.

-Foundations

Foundations with no reinforcement bars are to have a thickness equal to 200 mm or more.

For foundations containing reinforcement bars as well as steel fibres, the minimum required bar reinforcement is the same as for slabs;

$$A_s \geq 0.25k_w A_c (f_{tk} - 2.7f_{tk,res}) / f_{sk} \quad (\text{Eq. 3-7})$$

where k_w is $1.5 - h / h_1 \geq 1.0$
 h is the total height of the cross-section, and h_1 is 1.0 m

(Eq. 3-7) is derived in *Appendix B*.

-Walls

Steel fibre reinforced walls with a height up to 3 m are to have a thickness equal to 120 mm or more. For higher walls, the minimum thickness is to be increased with 30mm. Slenderness rules as for columns apply.

Walls reinforced with both steel fibres and conventional bars are to have bar reinforcement in the main direction with a cross-section area equal to;

$$A_s = 0.6A_c (f_{tk} - 2f_{tk,res}) / f_{sk} \quad \text{horizontally in outer walls} \quad (\text{Eq. 3-8})$$

$$A_s = 0.3A_c (f_{tk} - 2.7f_{tk,res}) / f_{sk} \quad \text{in remaining walls} \quad (\text{Eq. 3-9})$$

-Columns

Columns can be constructed without bar reinforcement if it is proven that the chosen fibre amount is sufficient to carry forces caused by load, shrinkage and temperature changes.

Columns reinforced with steel fibres only are to have a cross-sectional dimension equal to 200 mm or more.

-Slabs

On the tension side of a slab in span and over support, the cross-section area of the reinforcement bars in the two main directions is to be;

$$A_{sv} \geq 0.25k_w A_c (f_{tk} - 2.7f_{tk,res}) / f_{sk} \quad (\text{Eq. 3-10})$$

where k_w is $1.5 - h/h_1 \geq 1.0$
 h is the total height of the cross-section, and h_1 is 1.0 m

3.2.4.2 Cracking

Calculations in the cracking state of SFRC are based on a stabilized crack pattern.

For SFRC, the concrete's cracking state can be determined due to NS 3473 A15.6 [NS3473 Norges Standardiseringsråd, 2003]. Steel fibres reduce the concrete's crack widths, as the fibres transport stresses over the cracks. The presence of steel fibres is allowed for by calculating the reinforcement stress based on the stress-strain relation with a uniform residual stress in the tension zone of the cross-section.

For a given load situation, steel fibres cause an increased height of the cross-section's compression zone as well as reduced stress in the reinforcement bars. The NPG for SFRC, [Several distributors, 2006], provides a simplified method for calculating the height of the compression zone and the reinforcement stresses in its Appendix A.9.2.

The calculation method given in Appendix A.9.2 includes;

- Calculation of the compression zone height for the given load
- Calculation of the tension in the reinforcement bars
- Calculation of the crack widths based on strains in reinforcement bars according to NS 3473 A.15.6.

3.2.4.3 Deflection

Deflection in SLS is not mentioned in the NPG for SFRC.

3.3 Guidance for the Design of Steel-Fibre-Reinforced Concrete - UK

3.3.1 General

The GD of SFRC is published by The Concrete Society in the United Kingdom. The report reviews the methods currently used for FRC, with the aim of promoting an understanding of the technical issues involved, and act as guidance for the design of SFRC.

The GD of SFRC summarises the range of current applications for SFRC, including ground-supported and pile-supported slabs, sprayed concrete, composite slabs on steel decking and pre-cast units.

Although steel fibres are widely used in the UK and elsewhere, clear information is still lacking about the nature, use and properties of FRC, and there are no agreed design approaches for many of the current applications. The GD of SFRC is intended to provide an introduction to this type of reinforcement, with guidelines on design and report [Concrete society, -07].

3.3.2 Material qualities

In general, the concrete in the applications covered by the GD of SFRC has a fibre content of around 40kg/m^3 (~0.5 vol.-%), and in the current report's scope of work, an upper fibre content limit of 80kg/m^3 is defined. According to the GD of SFRC, the fibres have no effect

on the mechanical properties of plain concrete before cracking if the fibre content is below the previous defined upper limit. Consequently, material properties of uncracked SFRC, such as axial tensile strength and flexural strength, can be estimated by treating the SFRC as plain concrete.

The residual flexural strength of SFRC can, on the other hand, not be calculated reliably in terms of the properties of the plain concrete matrix and the steel fibres, and is consequently to be determined experimentally. Standard test methods are available to determine the residual strength in bending and tension and its toughness.

The Japanese beam test JCI-SF4, proposed by the Japanese Concrete Institute (JCI), is currently the most used beam test among steel fibre manufacturers in the UK. In this test, a minimum of six 150x150x600 beams are loaded to failure under third point loading across a span of 450mm. The test is only valid if specimens fail due to the formation of a flexural crack in the middle third of the beam. The outputs from the JCI test are toughness and equivalent flexural strength. The equivalent flexural strength is calculated from the average failure up to a deflection of 3mm. The toughness T_{JCI} , which corresponds to the energy absorbed by the beam, is given by the area under the load displacement diagram up to a prescribed mid-point deflection of $\delta_{150} = \text{span}/150 = 3\text{mm}$. The equivalent flexural strength at a deflection of 3mm ($f_{cf\text{fleq}3}$) is defined as;

$$f_{cf\text{fleq}3} = T_{JCI} L / (\delta_{150} b h^2) \quad (\text{Eq. 3-11})$$

where L test span
 b section width
 h section depth

A disadvantage of the JCI beam test is that the load is not related to the crack width. Therefore, the crack width corresponding to a given mid-span deflection of 3mm can vary significantly dependent on the position of the crack. Although JCI-SF4 is the most used beam test at the present time, it is likely to be superseded by BS EN 14651:2005 in due course.

BS EN 14651 specifies a method for measuring the flexural tensile strength of metallic fibre reinforced concrete in moulded test specimens. The testing method is intended for metallic fibres no longer than 60mm. The 150x150mm beams are centrally loaded over a 500mm simple supported span. The specimens are notched at mid-span, which has the advantage that the crack forms in a predefined position and not the weakest section. The performance is specified in terms of the relationship between applied load and the crack opening displacement (CMOD), which can either be measured directly or calculated in terms of the central deflection. The LOP is defined as the highest load (F_L) up to a CMOD of 0.05mm. The centre-point load is also recorded at a CMOD of 0.5mm, 1.5mm, 2.5mm and 3.5mm. The flexural strength of the SFRC test beam, f_L , is calculated in terms of the centre-span load, F_L , as follows;

$$f_L = 6M_L / b h_{sp}^2 = 3F_L L / 2b h_{sp}^2 \quad (\text{Eq. 3-12})$$

where h_{sp} depth of the beam above the notch = 125±1mm
 b section width
 L span

The residual flexural strengths of the SFRC test beam are calculated in terms of the centre-span load, F_{Ri} , as follows;

$$f_{Ri} = 6M_L / bh_{sp}^2 = 3F_{Ri}L / 2bh_{sp}^2 \quad (\text{Eq. 3-13})$$

The BS EN 14651 beam test is originally developed by RILEM, and hence similar to the RILEM beam test. The RILEM beam test forms the basis of the RILEM stress-crack width (σ -w) design method and stress-strain (σ - ϵ) design method, see *Chapter 3.4*.

3.3.3 Ultimate Limit State (ULS)

3.3.3.1 General

To be consistent with the factors in Eurocode 2 [British Standards Institution, 2004] for concrete without fibres, the material partial safety factor for the residual strength of FRC, $f_{tk,res}$, is given as;

$$\gamma_m = 1.5$$

3.3.3.2 Bending

The simplified stress block in *Figure 3.7* is used when deriving the design ultimate moment of resistance for concrete sections without conventional steel reinforcement.

By assuming axial equilibrium, the following expression for the cross-section compression height x is derived;

$$\begin{aligned} f_{cd} \cdot 0.8x \cdot b &= f_{td} \cdot (h - x) \cdot b \\ f_{cd} \cdot 0.8x + f_{td} \cdot x &= f_{td} \cdot h \\ x \cdot (0.8f_{cd} + f_{td}) &= f_{td} \cdot h \\ x &= \frac{f_{td} \cdot h}{(0.8f_{cd} + f_{td})} \end{aligned} \quad (\text{Eq. 3-14})$$

Further, the design ultimate moment of resistance M_p is found by assuming moment equilibrium, i.e. multiplying the compression force with the arm between the tension and compression force.

$$\begin{aligned} M_p &= f_{cd} \cdot b \cdot 0.8x \cdot (h - 0.4x - 0.5 \cdot (h - x)) \\ M_p &= f_{cd} \cdot b \cdot 0.8x \cdot (0.5h + 0.1x) \\ M_p &= f_{cd} \cdot b \cdot 0.8 \cdot \frac{f_{td} \cdot h}{(0.8f_{cd} + f_{td})} \cdot (0.5h + 0.1 \cdot \frac{f_{td} \cdot h}{(0.8f_{cd} + f_{td})}) \end{aligned}$$

$$M_p = 0.8f_{cd}f_{td}bh^2 \frac{(0.5 + \frac{0.1f_{td}}{(0.8f_{cd} + f_{td})})}{(0.8f_{cd} + f_{td})} \quad (\text{Eq. 3-15})$$

where	f_{cd}	= design compressive strength of concrete
	$f_{td} = 0.37R_{e,3}f_{ctk,fl} / \gamma_c$	= design residual strength of the concrete
	$f_{ctk,fl}$	= characteristic flexural strength
	γ_c	= material partial safety factor, set to 1.5 in ULS
	$R_{e,3}$	= equivalent flexural strength ratio, determined by performance testing up to a deflection of 3mm

$R_{e,3}$ is derived in the Japanese beam test, or it can be estimated from the results of the BS EN 14651:2005 or the RILEM notched beam test. According to the GD of SFRC, $R_{e,3}$ can not be derived theoretically, and one is therefore dependent on performing beam tests to be able to calculate the design ultimate moment of resistance.

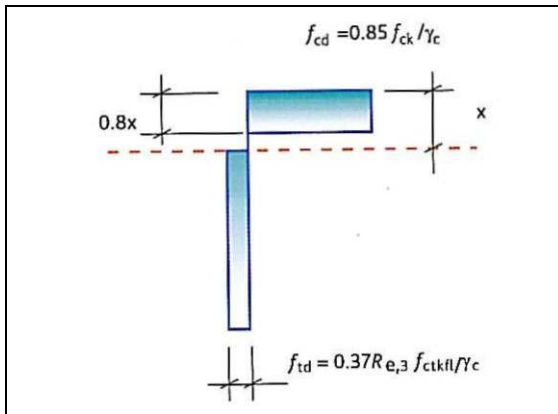

Figure 3.7: Simplified stress block for SFRC, [Concrete society, 2007].

The equation describing the design ultimate moment of resistance is highly dependent on the design compressive strength of the concrete, i.e. the concrete quality.

For sections with supplementary conventional steel reinforcement bars, the above defined expression for the design ultimate moment, M_p , is modified to incorporate the effect of the conventional reinforcement. The only difference from the analysis for conventional reinforced concrete is that the tensile stress in the concrete is assumed to be f_{td} . The depth to the neutral axis is found by considering axial equilibrium and the design moment of resistance is found by taking moments about the tension reinforcement, Figure 3.8.

Axial equilibrium, Figure 3.8;

$$C_c + C_s = T + b(h - x)f_{td} \quad (\text{Eq. 3-16})$$

where	$C_c = 0.8bxf_{cd}$	force resultant of the concrete in its compression zone
	$C_s = f_{sc}A_{sc}$	force resultant of the reinforcement bar in the compression zone
	$T = A_s f_{yd}$	force resultant of the tension reinforcement bar

Assuming moment equilibrium about the tension reinforcement, the moment of resistance for sections with supplementary reinforcement is derived to be;

$$M = C_c (d - 0.4x) + C_s (d - d') - b(h - x)f_{td} (d - 0.5h - 0.5x) \quad (\text{Eq. 3-17})$$

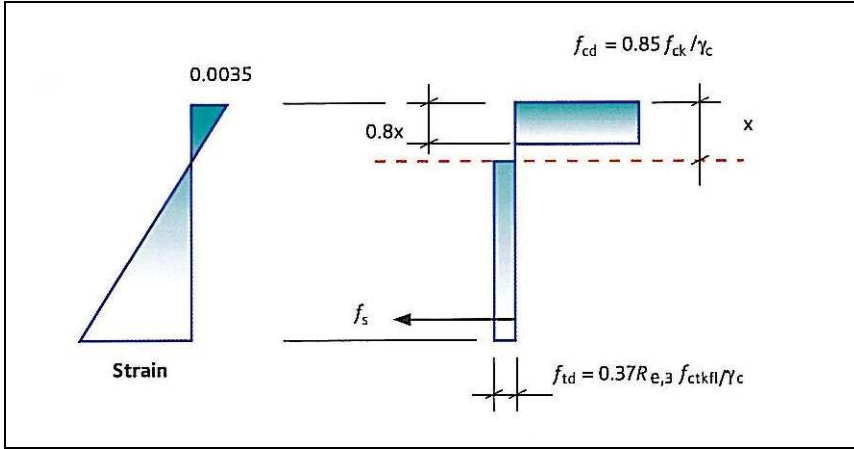

Figure 3.8: Simplified stress block for SFRC with supplementary reinforcement.

3.3.3.3 Shear

There is no agreed method for calculating the design shear strength of FRC without conventional reinforcement. Fibres increase the shear strength if longitudinal reinforcement bars are provided. The RILEM design recommendations are broadly adopted in GD of SFRC, but have been updated to be in line with Eurocode 2. The design shear strength of SFRC with supplementary steel flexural reinforcement is given by:

$$V_{Rd,c} = (C_{Rd,c} k (100 \rho_l f_{ck})^{1/3} + k_1 \sigma_{cp} + v_{fd}) b_w d + V_{wd} \quad (\text{Eq. 3-18})$$

where $C_{Rd,c}$ and k_1 are nationally determined parameters with recommended values of $0.18/\gamma_c$ and 0.15 respectively

$\rho_l = A_s / b_w d \leq 0.02$ where A_s is the area of tensile flexural reinforcement

b_w = width of web

d = effective depth

$\sigma_{cp} = N_{ed} / A_c \leq 0.2 f_{cd}$

N_{ed} = axial force due to load or prestress

$k = 1 + \sqrt{(200/d)} \leq 2$ with d in mm

$v_{fd} = 0.7 k_f k \tau_{fd}$

k_f = factor taking into account the contribution of flanges in a T-section

τ_{fd} = design value of the increase in shear strength due to steel fibres

V_{wd} = contribution of the stirrups to shear strength

The GD of SFRC adopts the RILEM σ - ϵ guideline's statement that minimum shear reinforcement is not required in steel fibre reinforced beams, but that it must be guaranteed that the fibres have a significant influence on the shear strength.

3.3.4 Serviceability Limit State (SLS)

3.3.4.1 Minimum reinforcement

Design codes for reinforced concrete require a minimum amount of reinforcement to be provided in all members to ensure multiple cracking. The minimum area of reinforcement for SFRC is similar to that of conventional reinforced concrete, but the minimum area of reinforcement, and crack widths, are reduced by the fibres that bridge cracks, and consequently increase the residual tensile stress in the concrete after cracking. The GD of SFRC has adopted its design method for minimum reinforcement from the RILEM σ - ϵ design method, and updated it to be consistent with Eurocode 2. For calculating the minimum area of reinforcement required to limit the design crack width to approximately 0.25mm, the following equation is given;

$$A_s / A_{ct} = (kk_c f_{ctef} - 0.45 f_{Rm1} / 1.4) / (f_{yk} / 1.4) \quad (\text{Eq. 3-19})$$

- where
- f_{Rm1} average residual tensile strength of the SFRC at the moment when a crack is expected to occur.
 - A_s area of reinforcement within the tensile zone which satisfies the design crack width.
 - A_{ct} area of concrete in the tensile zone.
 - f_{ctef} tensile strength of the concrete at the time cracks are first expected to occur.
 - k_c coefficient which takes account of the shape of the stress distribution in the concrete immediately before cracking.
 - k coefficient that allows for the effect of non-uniform self-equilibrating stresses as defined in Eurocode 2.
 - f_{yk} characteristic yield strength of reinforcement (MPa).

3.3.4.2 Cracking

Crack control is required in all structures. At the same time, the GD of SFRC states that crack widths cannot be controlled in statically determinate members reinforced with only steel fibres unless sufficient fibres (typically more than 80kg/m³) are provided to give a strain hardening response. The design of such composites is outside the aforesaid guideline's scope of work, and thus it is suggested that statically determinate steel fibre reinforced beams and slabs should not be designed using the recommendations in the GD of SFRC unless supplementary steel reinforcement bars are provided for flexure.

No calculation method is mentioned in the GD of SFRC for estimating crack widths, however it is referred to the RILEM σ - ϵ design guideline for crack width estimation.

3.3.4.3 Deflection

Steel fibres bridging the concrete cracks enhances tension stiffening in cracked concrete, hence deflections will be less in SFRC than reinforced concrete slabs with the same area of bar reinforcement. The GD of SFRC states that for uncracked concrete slabs, an elastic analysis using an effective elastic modulus to account for creep can be used for estimating deflections, while a more complex non-linear analysis is required to calculate deflections in cracked steel fibre reinforced slabs without longitudinal reinforcement.

3.4 RILEM

3.4.1 General

The design of SFRC according to the σ - ε design method is based on the same fundamentals as the design of normal reinforced concrete [RILEM, 2003]. The method is valid for concrete with compressive strengths of up to C50/60. As a general framework for the design method proposed, the European pre-standard ENV 1992-1-1 (Eurocode 2) is used. The current RILEM guideline is intended for cases in which steel fibres are used for structural purposes, and not e.g. for slabs on grade.

The RILEM σ - ε design method defines a load-deflection or load-CMOD (crack mouth opening displacement) relationship, where the load at predefined deflections/CMODs is the base for determining the concrete's residual or equivalent flexural strengths.

3.4.2 Material qualities

The compressive strength of SFRC should be determined by means of standard tests, either on concrete cylinders or concrete cubes. Further, when bending tests are not performed, the estimated mean and characteristic flexural tensile strength of the steel fibre concrete may be derived from the determined compressive strength.

The residual flexural tensile strength is determined in terms of areas under the load-deflection curve obtained by the CMOD or deflection controlled bending test. According to the current test method, a minimum of three concrete beams with a 150x150mm cross-section are used as standard test specimens. The specimens are to have a minimum length of 550mm and a sawn notch at mid-span. The testing method is intended for metallic fibres no longer than 60mm and aggregate less than 32mm. The span length of the three-point loading test is 500mm, and the load is applied at mid-span through one roller with a diameter of 30mm. During testing, the value of the load and net-deflection at mid-span are recorded continuously. The deflection is to be measured at both sides of the specimen ($\delta = (\delta_I + \delta_{II})/2$), while the measurement of the CMOD is optional. If the crack starts outside the notch, the test has to be rejected. The residual flexural tensile strengths, $f_{R,I}$ and $f_{R,4}$, respectively, are defined at the following crack mouth opening displacement (CMOD_{*i*}) or mid span deflections ($\delta_{R,i}$);

$$\begin{array}{ll} CMOD_I = 0.5 \text{ mm} & - \quad \delta_{R,I} = 0.46 \text{ mm} \\ CMOD_4 = 3.5 \text{ mm} & - \quad \delta_{R,4} = 3.00 \text{ mm} \end{array}$$

and can be determined by means of the following expression;

$$f_{R,i} = \frac{3F_{R,i}L}{2bh_{sp}^2} \quad (\text{Eq. 3-20})$$

where b = width of specimen
 h_{sp} = distance between tip of the notch and top of cross-section
 L = span of the specimen
 $F_{R,i}$ = load recorded at CMOD_{*i*} or $\delta_{R,i}$

The relation between "characteristic" and "mean" residual flexural tensile strength is given as;

$$f_{fctk,L} = f_{fctm,L} - k_x S_p \quad (\text{Eq. 3-21})$$

where k_x = factor dependent on the number of specimens
 s_p = standard deviation

3.4.3 Ultimate Limit State (ULS)

3.4.3.1 Bending

The stresses in the SFRC in tension as well as in compression are derived from the stress-strain diagram shown in *Figure 3.9* and explained below.

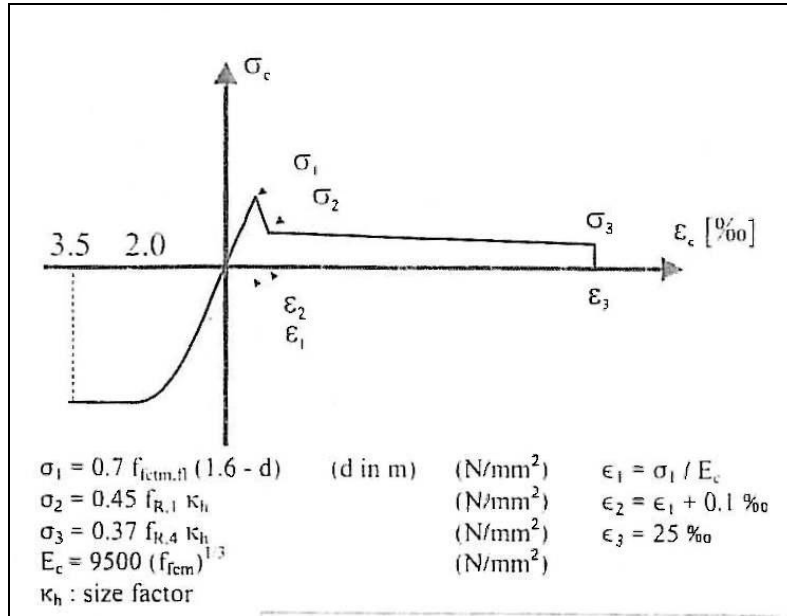

Figure 3.9: Stress-strain diagram [RILEM, 2003].

The residual flexural tensile strengths $f_{R,1}$ and $f_{R,4}$ are calculated considering a linear elastic stress distribution in the section, *Figure 3.10 a*. However, in reality, the stress distribution will be different, *Figure 3.10 b*. To calculate a more realistic stress in the cracked part of the section, the following assumptions have been made; the tensile stress in the cracked part of the steel fibre concrete section is constant, and the cracked height is equal to $\pm 0.66 \cdot h_{sp}$ at $F_{R,1}$ and to $\pm 0.90 \cdot h_{sp}$ at $F_{R,4}$ respectively. Requiring $M_1 = M_2$, σ_f can be expressed as;

$$\sigma_2 = \sigma_{f,1} = 0.45 f_{R,1}$$

$$\sigma_3 = \sigma_{f,4} = 0.37 f_{R,4}$$

To ensure sufficient anchor capacity for the steel fibres, the maximum CMOD in ULS is restricted to 3.5 mm, i.e. failure is defined at crack width 3.5 mm (residual flexural tensile strength $f_{R,4}$).

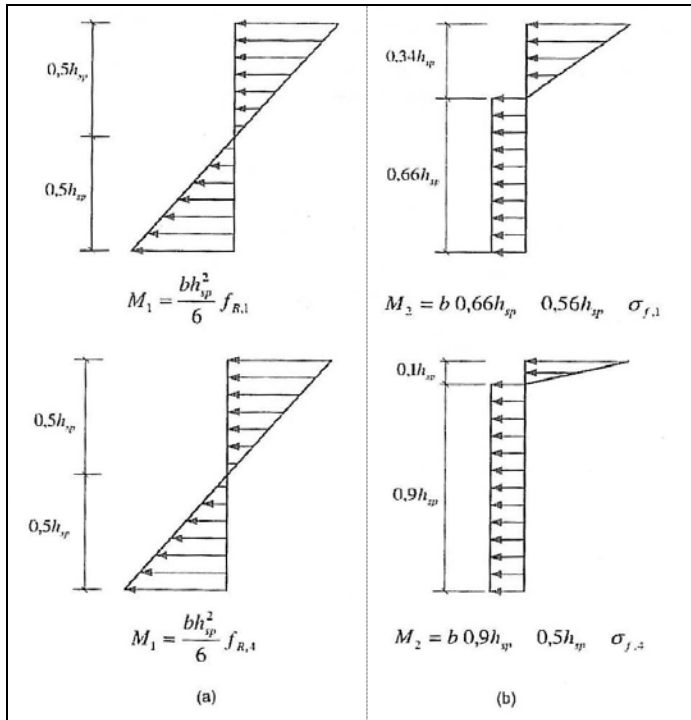

Figure 3.10: Stress distribution [RILEM, 2003].

Due to comparison between design method results and experimental results, [RILEM, 2003] has introduced a size-dependent safety factor given as;

$$\kappa_h = 1.0 - 0.6 \cdot \frac{h[cm] - 12.5}{47.5} \quad | \quad 12.5 \leq h \leq 60[cm] \quad (\text{Eq. 3-22})$$

The design ultimate moment of resistance for a section without conventional bar reinforcement is to be derived due to axial equilibrium of the cross-section in question. A clear definition of which stress value to use on such derivation (σ_2 , σ_3 , or an average value) is vainly sought for.

For sections with supplementary conventional steel reinforcement bars, the derivation of the design ultimate moment M is to be modified to incorporate the effect of the conventional reinforcement. The depth to the neutral axis can be found by considering axial equilibrium and the design moment of resistance can be found by taking moments about the tension reinforcement. The stresses in the reinforcement bars are derived from an idealized bi-linear stress-strain diagram. The strain is limited to 25‰ at the position of the reinforcement.

3.4.3.2 Shear

In [RILEM, 2003], the design shear resistance of a section of a beam, reinforced with both shear reinforcement and steel fibres, is given by the equation;

$$V_{Rd,3} = V_{cd} + V_{fd} + V_{wd} \quad (\text{Eq. 3-23})$$

where V_{cd} = shear resistance of the member without shear reinforcement
 V_{fd} = shear resistance contribution due to steel fibre
 V_{wd} = shear resistance contribution due to stirrups and/or inclined bars

The steel fibre's contribution to the shear resistance is given by;

$$V_{fd} = 0.7k_f k_l \tau_{fd} b_w d \quad (\text{Eq. 3-24})$$

where k_f = factor for taking into account the contribution of the flanges in a T-section
 $k_l = 1 + \sqrt{(200/d)} \leq 2$ with d in mm
 τ_{fd} = design value of the increase in shear strength due to steel fibres
 b_w = width of web
 d = effective depth

3.4.4 Serviceability Limit State (SLS)

3.4.4.1 General

When an uncracked section is used, the full SFRC section is assumed to be active, and both concrete and steel are assumed to be elastic in tension as well as in compression. When a cracked section is used, the SFRC is assumed to be elastic in compression, and capable of sustaining a tensile stress equal to $0.45 \cdot f_{R,I}$ [RILEM, 2003].

3.4.4.2 Minimum reinforcement

In [RILEM, 2003], the following formula is proposed for calculating the minimum reinforcement A_s in order to obtain controlled crack formation:

$$A_s = (k_c k k_p f_{fct,ef} - 0.45 f_{Rm,I}) \frac{A_{ct}}{\sigma_s} \quad (\text{Eq. 3-25})$$

where $f_{Rm,I}$ average residual flexural tensile strength of the SFRC at the moment when a crack is expected to occur
 A_s area of reinforcement within tensile zone
 A_{ct} area of concrete within tensile zone
 σ_s maximum stress permitted in the reinforcement immediately after formation of the crack
 $f_{fct,ef}$ the tensile strength of the concrete effective at the time when the cracks may first be expected to occur
 k_c stress distribution coefficient
 k coefficient which allows for the effect of non-uniform self-equilibrating stresses
 k_p coefficient which takes account of the prestressing effect

3.4.4.3 Cracking

In the absence of specific requirements, the criteria for the maximum design crack width (w_d) under the quasi-permanent combination (***) of loads, which are mentioned in *Table 3.1* for different exposure classes, may be assumed, [RILEM, 2003].

RILEM states that crack control is required in all structures, and that the crack control can be satisfied by at least one of the following conditions;

- presence of conventional steel bars
- presence of normal compressive forces (compression – prestressing)

- crack control maintained by the structural system itself (redistribution of internal moments and forces limited by the rotation capacity)

Criteria for crack width				
Exposure class (*)	Steel fibres	Steel fibres + ordinary reinforcement	steel fibres +	
			post-tensioning	pre-tensioning
1	(****)	(****)	0.2 mm	0.2 mm
2	0.3 mm	0.3 mm	0.2 mm	decompression (**)
3	Special crack limitations dependent upon the nature of the aggressive environment involved have to be taken.			
4				
5				

(*): see Appendix 2
 (**): the decompression limit requires that, under the frequent combination (***) of loads, all parts of the tendons or ducts lie at least 25 mm within concrete in compression
 (***): see ENV 1992-1-1 [1]
 (****): for exposure class 1, crack width has no influence on durability and the limit could be relaxed or deleted unless there are other reasons for its inclusion.

Table 3.1: Criteria for crack width.

In structures with both conventional bar reinforcement and steel fibre reinforcement, the calculation of the crack width corresponds to that of normal reinforced concrete. However, the stress in the steel bars has to be calculated, taking into account the beneficial effect of the steel fibres, i.e. a part of the tensile force $F_{f,t}$ which is taken up by the steel fibres.

The formula describing minimum reinforcement required (Chapter 3.4.4.2) can be used to calculate the reinforcement A_{sr} which satisfies the crack width limit.

3.4.4.4 Deflection

No specific calculation methods for deflection in SLS are mentioned in [RILEM, 2003].

3.5 Guideline comparison

The GD of SFRC defines an upper volume percent of fibre, approximately 80 kg/m³, in its scope of work. In the NPG and RILEM, on the other hand, no such upper limit seems to be defined.

The NPG and RILEM do not seem to mention deflections of concrete structure parts. The GD of SFRC states that deflections are to be estimated in the SLS.

The GD of SFRC has based many of its statements on the RILEM guideline, and updated them to be consistent with Eurocode 2.

NPG for SFRC states that steel fibre can be used as sole reinforcement only for structures with safety level 1. Structures with safety level 2 or higher are to have conventional bar reinforcement to transfer all external forces in addition to the fibre reinforcement.

In the GD of SFRC, the design ultimate moment of resistance, M_p , is, among other factors, dependent on the design compressive strength of concrete, f_{cd} . In the NPG, the design compressive strength of concrete, f_{cd} , is not included in the calculations of the design ultimate moment of resistance unless the residual stress $f_{tk,res}$ exceeds 2.5 N/mm^2 .

While the NPG for SFRC and DG of SFRC contains specific expressions describing the design ultimate moment of resistance, RILEM describes a stress-strain diagram, providing a basis for derivation of the ultimate moment of resistance.

According to both RILEM and GD of SFRC, the residual flexural strength of SFRC is to be determined experimentally. The NPG, on the other hand, opens for theoretical calculations to determine the residual flexural strength, possible combined with fibre pull-out tests. The demand for an experimental determination of the residual flexural strength in RILEM and the GD of SFRC, complicates a comparison of bending and shear resistance for a given structure between the two guidelines in question.

The preferable method for comparing the previous mentioned guidelines would be to perform a calculation for a given 'beam in bending'-situation, and then show the different guideline's results in the same diagram. This is however complicated due to the previous mentioned requirement for an experimental determination of the residual flexural strength in RILEM and the GD of SFRC.

4 Consequences on a concrete building

4.1 Design premises

4.1.1 General

In this chapter, a chosen concrete building with a given load situation is designed. The different structural elements, i.e. foundations, walls, columns and slabs, are designed and reinforced due to their moment- and shear capacity. Three different design approaches are used;

- design and construction due to traditional methods
- design and construction with a given steel fibre content equal to 1 vol.-%
- design and construction with steel fibres as sole reinforcement.

The first design approach is presented in *Chapter 4.2*, and consists of the traditional design method with conventional bar reinforcement due to NS3473. In the second design approach, *Chapter 4.3*, 1 vol.-% steel fibre is added to the concrete, and the additional bar reinforcement required is calculated based on the NPG [Several contributors, 2006], and NS3473. The third design approach is based on sole steel fibre reinforcement, and thus necessary fibre volume ratio required to avoid conventional bar reinforcement is calculated based on the NPG [Several contributors, 2006], *Chapter 4.4*.

Effects and calculations due to deflections and cracking are disregarded.

4.1.2 Geometry

The structure chosen for these calculations is a small business building consisting of 3 floors and a basement. The floors are made of in-situ cast concrete, with a typical span of 6 meters. The roof consists of isolated in-situ cast concrete, also with a typical span of 6 meters. The floors are carried by rectangular concrete columns, which again are carried by quadratic concrete foundations. A foundation is typically carrying a load expanse of $6 \cdot 6 = 36 \text{ m}^2$ from each of the floors above. It is assumed office premises on all floors. The floor height, and consequently the column's buckling length, is set to 2.8 m. In the basement, the outer walls are made of in-situ cast concrete.

The foundations' size and geometry are decided based on the calculated design load in the Ultimate Limit State (ULS) and the allowed ground pressure beneath the foundations. Allowed ground pressure beneath the foundations is assumed to be 250 kN/m^2 .

4.1.3 Materials

A concrete quality B30 is assumed for all structure parts, which according to NS3473:2003 [NS3473 Norges Standardiseringsråd, 2003] gives the following material properties;

- Characteristic compression strength (cube); $f_{ck} = 37.0 \text{ N/mm}^2$
- Tensile structure strength; $f_m = 1.8 \text{ N/mm}^2$
- Compressive structure strength; $f_{cn} = 23.8 \text{ N/mm}^2$

NS3473:2003 [NS3473 Norges Standardiseringsråd, 2003] defines the following material safety factors;

- Material safety factor concrete; $\gamma_c = 1.4$
- Material safety factor bar reinforcement; $\gamma_s = 1.25$

- Material safety factor steel fibre; $\gamma_{sf} = 1.55$

In this report, the steel fibres are assumed to have an average stress, $\sigma_{fk,mid}$ equal to 500 N/mm². η_0 , the relationship between the resultant force of fibres with a randomly distributed direction and the resultant force of uniform directional fibres with the same stress, is assumed to be 1/3.

The quality of the steel reinforcement bars is B500C.

4.1.4 Load and dimensions

4.1.4.1 General

In the serviceability limit state, the slabs and the roof in the building are subjected to permanent and variable loads as described in the tables beneath, *Table 4.1 –Table 4.4*. A concrete floor thickness equal to 200mm is assumed in the following load estimations.

Table 4.1: Permanent load roof

Self-weight roof	Concrete slab, 25·0.2 kN/m ²	5.0
	Roofing/ceiling	1.0
		6.0 kN/m²

Table 4.2: Permanent load floors

Self-weight floor	Concrete slab, 25·0.2 kN/m ²	5.0
	Roofing/ceiling/walls	1.0
		6.0 kN/m²

Table 4.3: Variable load roof

Load on roof	Snow load	2.8
	Ground load=3.5 , $\mu=0.8$	
		2.8 kN/m²

Table 4.4: Variable load floors

Load on floor	Field load	3.0
	category B	
		3.0 kN/m²

Load combinations due to NS 3490:2004 [NS3473 Norges Standardiseringsråd, 2004] 9.4.2, equation 12 and 13, result in a combination of load safety factors as shown in *Table 4.5*.

Table 4.5: Load combinations due to NS 3490:2004

	Permanent load	Dominant variable load	Other variable loads
Serviceability Limit State	1.0	1.0	1.0
Ultimate Limit State - B1 (12)	1.35	1.05	1.05
Ultimate Limit State - B2 (13)	1.2	1.5	1.05

4.1.4.2 Foundations

The total permanent load onto the foundation, carrying $6.6 \text{ m}^2 = 36 \text{ m}^2$ slab expanse from each floor, is;

$$G = 6.0 \cdot 4 \cdot 36 = \underline{864} \text{ kN}$$

From *Table 4.1 – Table 4.5*, the design load in ULS onto a foundation, carrying 36 m^2 slab expanse from each floor, is as follows:

$$N_{\gamma B1} = 1.35 \cdot 864 + 1.05 \cdot (2.8 + 3 + 3 + 3) \cdot 36 = 1166 + 446 = \underline{1612} \text{ kN}$$

$$N_{\gamma B2} = 1.2 \cdot 864 + 1.5 \cdot (3 + 3 + 3) \cdot 36 + 1.05 \cdot 2.8 \cdot 36 = 1037 + 486 + 106 = \underline{1629} \text{ kN}$$

Consequently, load combination B2, due to NS 3490:2004 9.4.2 equation 13, gives the maximum design load in ULS.

The allowed response pressure in the ground is set to be 250 kN/m^2 , consequently, necessary foundation area is;

$$A_{\text{Foundation}} = \frac{1629}{250} = \underline{6.52} \text{ m}^2$$

A foundation dimension $2.7 \cdot 2.7 = 7.29 \text{ m}^2$ is chosen, giving an actual response pressure on the foundation;

$$q = \frac{1629}{7.29} = \underline{223.5} \text{ kN/m}^2$$

The moment at the edge of a 300mm wide column is accordingly;

$$M_{\gamma} = \frac{q \cdot l^2}{2} = \frac{223.4 \cdot 1.2^2}{2} = \underline{160.8} \text{ kNm/m}$$

In order to avoid shear reinforcement at a section $2d$ from the edge of the column, a foundation height equal to 400mm is chosen, and d is assumed to be 344mm. The shear force at the critical section, at a distance d from the edge of column, is found to be;

$$V_{\gamma,d} = 1628.6 - (0.300 + 2 \cdot 0.344)^2 \cdot 223.4 = \underline{1411} \text{ kN}$$

Further, the shear force at the distance $2d$ from the edge of the column is;

$$V_{\gamma,2d} = 1628.6 - (0.300 + 4 \cdot 0.344)^2 \cdot 223.4 = \underline{1001} \text{ kN}$$

4.1.4.3 Walls

For the current walls, two different load situations are to be considered;

- Load situation L1 - vertical forces are dominant due to structure failure
- Load situation L2 - horizontal forces are dominant due to structure failure

Load situation L1 - vertical forces are dominant due to structure failure

The total permanent load onto a basement wall, carrying $6 \cdot 0.5 = 3 \text{ m}^2/\text{m}$ slab from each floor, is;

$$G = (6.0 \cdot 4) \cdot 3 = \underline{72} \text{ kN/m}$$

From *Table 4.1 – Table 4.5*, the vertical design load in ULS onto a basement wall is as follows:

$$N_{\gamma B1} = 1.35 \cdot 72 + 1.05 \cdot (2.8 + 3 + 3 + 3) \cdot 3 = 97.2 + 37.2 = \underline{134.4} \text{ kN/m}$$

$$N_{\gamma B2} = 1.2 \cdot 72 + 1.5 \cdot (3 + 3 + 3) \cdot 3 + 1.05 \cdot 2.8 \cdot 3 = 86.4 + 40.5 + 8.8 = \underline{135.7} \text{ kN/m}$$

Load combination B2, due to NS 3490:2004 9.4.2 equation 13, gives the maximal vertical design load in ULS.

NS 3473:2003 12.1.2 requires a minimum load eccentricity in the unfavourable direction of the cross-section. For the basement walls, the eccentricity can be set to 20mm, which gives an eccentricity-moment equal to;

$$M_e = N_{\gamma B2} \cdot 0.02 = 135.7 \cdot 0.02 = \underline{2.7} \text{ kNm/m}$$

The basement concrete walls are also assumed to be subjected to horizontal loads due to ground pressure, P_γ , and terrain load, P_q , *Figure 4.1*.

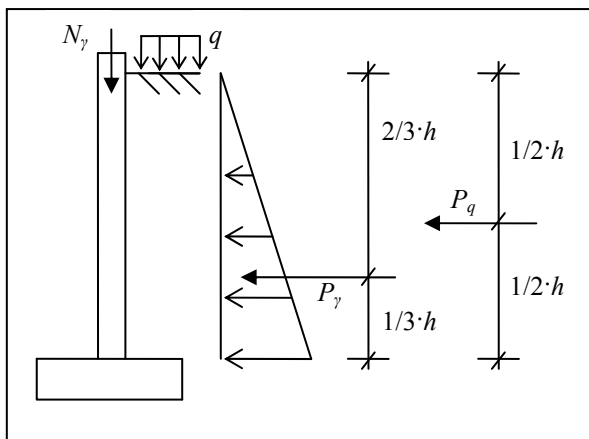

Figure 4.1: Basement wall subjected to horizontal load.

The horizontal design loads in ULS onto a basement wall are as follows:

$$P_\gamma = \frac{1}{2} \cdot K \cdot \gamma \cdot h^2$$

$$P_q = q \cdot \gamma_f \cdot h \cdot K$$

where $K = 0.5$

$$\begin{aligned}\gamma &= 20 \text{ kN/m}^3 \\ h &= 2.5 \text{ m} \\ q &= 3 \text{ kN/m}^3 \\ \gamma_f &= 1.05\end{aligned}$$

$$P_\gamma = \frac{1}{2} \cdot 0.5 \cdot 20 \cdot 2.5^2 = \underline{31.2} \text{ kN/m}$$

$$P_q = 3 \cdot 1.05 \cdot 2.5 \cdot 0.5 = \underline{3.9} \text{ kN/m}$$

The design moment in the critical section due to the horizontal loads is;

$$M_h = P_\gamma \cdot \frac{2 \cdot h}{9} + P_q \cdot \frac{h}{4} = 17.3 + 2.4 = \underline{19.7} \text{ kNm/m}$$

The design forces at the critical section of the concrete wall for load situation L1 are;

$$\text{Moment - L1; } M_{\gamma L1} = M_h + M_e = 19.7 + 2.7 = \underline{22.4} \text{ kNm/m}$$

$$\text{Vertical load - L1; } N_{\gamma L1} = \underline{135.7} \text{ kN/m}$$

Load situation L2 - horizontal forces are dominant due to structure failure

When the horizontal forces are considered dominant due to structure failure, the vertical forces are defined to be favourable, and therefore only the vertical load self weight, with a load factor 1.0, is included. Hence, the vertical design load for load situation L2 is;

$$N_{\gamma B1} = 1.0 \cdot 72 = \underline{72.0} \text{ kN/m}$$

NS 3473:2003 12.1 gives an eccentricity-moment equal to;

$$M_e = N_{\gamma B} \cdot 0.02 = 72.0 \cdot 0.02 = \underline{1.4} \text{ kNm/m}$$

As described above, the basement concrete walls are also assumed to be subjected to horizontal loads due to ground pressure, P_γ , and terrain load, P_q . When horizontal forces are defined dominating due to structure failure, the horizontal load due to terrain load is to have a load factor $\gamma_f = 1.5$. This gives;

$$P_\gamma = \frac{1}{2} \cdot 0.5 \cdot 20 \cdot 2.5^2 = \underline{31.2} \text{ kN/m}$$

$$P_q = 3 \cdot 1.5 \cdot 2.5 \cdot 0.5 = \underline{5.6} \text{ kN/m}$$

The design moment in the critical section due to the horizontal loads is;

$$M_h = P_\gamma \cdot \frac{2 \cdot h}{9} + P_q \cdot \frac{h}{4} = 17.3 + 3.5 = \underline{20.8} \text{ kNm/m}$$

The design forces at the critical section of the concrete wall for load situation L2 are;

$$\text{Moment – L2; } M_{\gamma L2} = M_h + M_e = 20.8 + 1.4 = \underline{22.2} \text{ kNm/m}$$

$$\text{Vertical load – L2; } N_{\gamma L2} = \underline{72.0} \text{ kN/m}$$

A wall thickness equal to 180 mm is chosen, and d is assumed to be 140mm.

4.1.4.4 Columns

The total permanent load onto a basement column, carrying $6 \cdot 6 = 36 \text{ m}^2$ slab expanse on each floor, is;

$$G = (6.0 \cdot 4) \cdot 36 = \underline{864} \text{ kN}$$

From *Table 4.1 – Table 4.5*, the design load in ULS onto a basement column is:

$$N_{\gamma B1} = 1.35 \cdot 864 + 1.05 \cdot (2.8 + 3 + 3 + 3) \cdot 36 = 1166 + 446 = \underline{1612} \text{ kN}$$

$$N_{\gamma B2} = 1.2 \cdot 864 + 1.5 \cdot (3 + 3 + 3) \cdot 36 + 1.05 \cdot 2.8 \cdot 36 = 1037 + 486 + 106 = \underline{1629} \text{ kN}$$

Load combination B2, due to NS 3490:2004 9.4.2 equation 13, gives the maximal design load in ULS.

NS 3473:2003 12.1.2 requires a minimum load eccentricity in the unfavourable direction of the cross-section. For the basement columns, the eccentricity can be set to 20mm, which gives an eccentricity-moment equal to;

$$M_e = N_{\gamma B2} \cdot 0.02 = 1628.6 \cdot 0.02 = \underline{32.6} \text{ kNm}$$

Basement columns with dimension 300x350 are chosen, and d in the critical direction is assumed to be 260 mm.

4.1.4.5 Slabs

The self-weight of the slab is;

$$g = \underline{6.0} \text{ kN/m}^2$$

From *Table 4.1 – Table 4.5*, the design load in ULS onto a slab is:

$$n_{\gamma B1} = 1.35 \cdot 6.0 + 1.05 \cdot 3.0 = 8.1 + 3.2 = \underline{11.3} \text{ kN/m}^2$$

$$n_{\gamma B2} = 1.2 \cdot 6.0 + 1.5 \cdot 3.0 = 7.2 + 4.5 = \underline{11.7} \text{ kN/m}^2$$

Load combination B2, due to NS 3490:2004 9.4.2 equation 13, gives the maximal design load in ULS.

Due to calculations in the program Flatedekke [Sletten, 2001], *Appendix F*, the design moment is found above the column support;

$$M_{\gamma} = \underline{85.2} \text{ kNm/m}$$

Slabs with thickness 200 mm are chosen, and d is assumed to be 160 mm

The total axial force to be transferred from a slab to a column is;

$$N_{\gamma} = n_{\gamma B2} \cdot 36 = 11.7 \cdot 36 = \underline{421} \text{ kN}$$

The shear force at the critical section, at a distance d from the edge of column, is therefore found to be;

$$V_{\gamma,d} = 421.2 - (0.300 + 2 \cdot 0.140) \cdot (0.400 + 2 \cdot 0.140) \cdot 11.7 = \underline{417} \text{ kN}$$

Further, the shear force at the distance $2d$ from the edge of the column is;

$$V_{\gamma,2d} = 421.2 - (0.300 + 4 \cdot 0.140) \cdot (0.400 + 4 \cdot 0.140) \cdot 11.7 = \underline{412} \text{ kN}$$

4.1.4.6 Load situation - summary

A summary of the design loads for the different structure parts in question is given in *Table 4.6*.

Table 4.6: Design loads for the different structure parts in question

	Foundation	Wall – L1	Wall – L2	Column	Slab
Design moment [kNm]	160.8*	22.4*	22.2*	32.6	85.2*
Design axial force [kN]	-	135.7*	72.0*	1629	-
Design shear at d [kN]	1411	35.1*	36.8*	-	417
Design shear at $2d$ [kN]	1001	-	-	-	412

*⁾ [Load/m]

4.2 Traditional design

4.2.1 Foundations

The foundation's moment capacity, shear capacity and required reinforcement due to traditional design are calculated in *Appendix C*.

Moment capacity: $M_{cd} = \underline{553.2} \text{ kNm/m}$

Shear capacity: $V_{cd,d} = \underline{185.4} \text{ kN/m}$

Total longitudinal bar reinforcement required in the lower edge of the 2.7m foundation is found to be:

$$A_s = 1229 \cdot 2.7 = \underline{3319} \text{ mm}^2 \text{ in each direction}$$

17 $\emptyset 16$ gives a bar reinforcement area equal to $A_s = 3418 \text{ mm}^2$

Total required shear reinforcement along the whole critical section, at distance d from the column edge, is;

$$A_{sv,d} = \underline{2396} \text{ mm}^2$$

8 $\emptyset 10$ reinforcement bars with a 45° inclination angle, on each side along the critical section, are chosen. This gives a total shear reinforcement equal to $(4 \cdot 8 \emptyset 10) = 2513 \text{ mm}^2$. Calculations in *Appendix C* found no requirement for shear reinforcement at section $2d$ from the edge of the column.

4.2.2 Walls

The basement walls are subjected to combined moment and axial forces, and hence the design is to be performed according to an M-N diagram. An M-N diagram for the current wall is established in an Excel spreadsheet by defining 7 different failure situations for the cross-section. The shape of the M-N diagram is also dependent on the amount of reinforcement bars in the cross-section, and hence the reinforcement bar amount is varied in the Excel spreadsheet until the boundaries of the M-N diagram enclose the current load situation.

The Excel calculations for the current wall are shown in *Appendix C*.

The total reinforcement bar areas necessary for the current cross-section and load situations are;

$$\text{Load situation L1; } A_{sL1} = \underline{500} \text{ mm}^2/\text{m}$$

$$\text{Load situation L2; } A_{sL2} = \underline{650} \text{ mm}^2/\text{m}$$

Vertical reinforcement $\emptyset 10c240$ on the outer as well as the inner side of the wall gives a total bar-reinforcement area equal to $A_s = 654 \text{ mm}^2/\text{m}$.

$$\text{Horizontal reinforcement; } A_{s,\min} \geq \underline{389} \text{ mm}^2$$

Horizontal reinforcement $\emptyset 8c300$ on the outer as well as the inner side of the wall gives a total bar-reinforcement area equal to $A_s = 402 \text{ mm}^2/\text{m}$.

The basement wall's capacity for shear along its critical section, at the lower edge at the wall, is in *Appendix C* found to be;

$$V_{cd,d} = \underline{85.9} \text{ kN/m}$$

Total shear force capacity of the concrete along the critical section, at the lower edge at the wall, is sufficient to carry the external horizontal forces.

4.2.3 Columns

Analogous to the basement walls, also the basement columns are subjected to combined moment and axial forces, and hence the design is to be performed according to an M-N diagram. An M-N diagram for the current column is established in an Excel spreadsheet by defining 7 different failure situations for the cross-section. The shape of the M-N diagram is also dependent on the amount of reinforcement bars in the cross-section, and hence the reinforcement bar amount is varied in the Excel spreadsheet until the boundaries of the M-N diagram enclose the current load situation.

The Excel calculation for the current column is shown in *Appendix C*.

The total reinforcement-bar area necessary for the current cross-section and load situation is;

$$A_s = \underline{500} \text{ mm}^2$$

According to *Appendix C*, NS3473:2003 defines the following required minimum amount of reinforcement for columns;

$$A_{s,\min} \geq 1050 \text{ mm}^2$$

$$A_s < A_{s,\min}$$

6Ø16 gives a bar-reinforcement-area equal to $A_s = 1206 \text{ mm}^2$

4.2.4 Slabs

The slab's moment capacity, shear capacity and required reinforcement due to traditional design are calculated in *Appendix C*.

Moment capacity: $M_{cd} = \underline{119.7} \text{ kNm/m}$

Shear capacity: $V_{cd,d} = \underline{128.9} \text{ kN/m}$

Necessary longitudinal bar reinforcement in the slab's upper edge over the support is:

$$A_s = \underline{1511} \text{ mm}^2/\text{m}$$

8Ø16c130 gives a bar-reinforcement-area equal to $A_s = 1547 \text{ mm}^2/\text{m}$.

Total required shear reinforcement along the whole critical section, at distance d from the column edge, is;

$$A_{sv,d} = \underline{251} \text{ mm}^2$$

2Ø8 reinforcement bars with a 45° inclination angle, on each side along the critical section, are chosen. This gives a total shear reinforcement area equal to $(4 \cdot 2 \cdot 08) = 402 \text{ mm}^2$.

Calculations in *Appendix C* found no requirement for shear reinforcement at section $2d$ from the edge of the column.

4.3 Design and construction with a manageable fibre content

4.3.1 General

In this report, a manageable fibre content is defined to be a fibre volume fraction equal to 1 %, which gives the following residual stress for the concrete;

$$f_{tk,res} = \eta_0 \cdot v_f \cdot \sigma_{fk,mid}$$

Where

$$\eta_0 = 1/3$$

$$\sigma_{fk,mid} = 500 \text{ N/mm}^2$$

$$v_f = 1 \text{ vol.-%} = 0.01$$

$$f_{tk,res} = 0.333 \cdot 0.01 \cdot 500 = \underline{1.67} \text{ N/mm}^2$$

4.3.2 Foundations

As shown in *Appendix D*, calculations due to the NPG [Several contributors, 2006] gives the following total moment capacity for the current foundation made of SFRC:

$$M_{fid} = \underline{68.0} \text{ kNm/m}$$

In *Chapter 4.1.4.2*, the design moment in the critical section of the foundation is found to be;

$$M_\gamma = \underline{160.8} \geq M_{fid}$$

The foundation's moment capacity is not sufficient to carry the design load, and accordingly, the foundation has to be reinforced with conventional reinforcement bars as well as steel fibre.

As described in *Chapter 3.2.3.2*, the moment capacity for the foundation in question, reinforced with both reinforcement bars and steel fibres, is determined as follows; For a given reinforcement situation, axial equilibrium over the cross-section is demanded, and with that the depth to the neutral axis is found. Further, the design moment of resistance is found by taking moments about the neutral axis. The tensile stress in the concrete is assumed to be f_{td} , including the steel fibres' contribution to the cross-section's capacity. A spreadsheet performing the above described operation is established in Excel, and the amount of reinforcement bars is varied until the desired moment of resistance is reached. The calculations in Excel for the current foundation are shown in *Appendix D*. To obtain a moment of resistance equal to 160.8 kNm, the following amount of reinforcement bars are necessary;

$$A_s = \underline{710} \text{ mm}^2/\text{m}$$

Consequently, the total necessary longitudinal bar reinforcement in the foundation is:

$$A_s = 710 \cdot 2.7 = \underline{1917} \text{ mm}^2$$

10 $\emptyset 16$ gives a total reinforcement bar area equal to $A_s = 2010 \text{ mm}^2$

For the current foundation, calculations due to NS 3473:2003 13.3.5.6 and NPG [Several contributors, 2006] performed in *Appendix D*, gives the following shear force capacity for the SFRC section;

$$V_d = V_{cd} + V_{fd} = \underline{1609.6} > V\gamma$$

As seen above, the total shear force capacity of the foundation is larger than the design shear force affecting the foundation, and consequently, there is no requirement for additional shear reinforcement.

4.3.3 Walls

The basement walls are subjected to a combination of bending and axial forces, and as described in *Chapter 3.2.3.2*, the design of the cross-section is to be performed according to an M-N diagram. An M-N diagram for the current wall is established in an Excel spreadsheet by defining 7 different failure situations for the cross-section. The shape of the M-N diagram is also dependent on the amount of reinforcement bars in the cross-section, and hence the reinforcement bar amount is varied until the boundaries of the M-N diagram enclose the current load situation.

The Excel calculations for the current wall are shown in *Appendix D*.

The total reinforcement bar areas necessary for the current cross-section and load situations are;

$$\text{Load situation L1; } A_{sL1} = \underline{0} \text{ mm}^2/\text{m}$$

$$\text{Load situation L2; } A_{sL2} = \underline{150} \text{ mm}^2/\text{m}$$

1 $\emptyset 10$ on the outer as well as the inner side of the wall gives a total bar-reinforcement area equal to $A_s = 157 \text{ mm}^2$.

$$\text{Horizontal reinforcement; } A_{s,\min} \geq \underline{-586} \text{ mm}^2$$

Hence, for the current situation no horizontal wall reinforcement is required.

4.3.4 Columns

Analogous to the basement walls, also the basement columns are subjected to combined moment and axial forces, and hence the design is to be performed according to an M-N diagram. An M-N diagram for the current column is established in an Excel spreadsheet by defining 7 different failure situations for the cross-section. The shape of the M-N diagram is also dependent on the amount of reinforcement bars in the cross-section, and hence the reinforcement bar amount is varied in the Excel spreadsheet until the boundaries of the M-N diagram enclose the current load situation.

The Excel calculation for the current column is shown in *Appendix D*.

The total reinforcement bar area necessary for the current cross-section and load situation is;

$$A_s = \underline{500} \text{ mm}^2$$

6ø12 gives a bar-reinforcement-area equal to $A_s=679 \text{ mm}^2$

As stated in *Chapter 3.2.4.1*, the NPG for SFRC [Several contributors, 2006] defines that columns can be constructed without bar reinforcement if it is proven that the chosen fibre amount is sufficient to carry forces caused by load, shrinkage and temperature changes.

4.3.5 Slabs

As described in *Chapter 3.2.3.2*, the moment capacity for the slab in question, reinforced with both reinforcement bars and steel fibres, is determined as follows; For a given reinforcement situation, axial equilibrium over the cross-section is demanded, and with that the depth to the neutral axis is found. Further, the design moment of resistance is found by taking moments about the neutral axis. The tensile stress in the concrete is assumed to be f_{td} , including the steel fibres contribution to the cross-section's capacity. A spreadsheet performing the above described operation is established in Excel, and the amount of reinforcement bars is varied until the desired moment of resistance is reached. The calculations in Excel for the current slab are shown in *Appendix D*. To obtain a moment of resistance equal to 85.2 kNm, the following amount of reinforcement bars are necessary;

$$A_s = 1220 \text{ mm}^2/\text{m}$$

6ø16c160 gives a reinforcement bar area equal to $A_s=1257 \text{ mm}^2$

For the current foundation, calculations due to NS 3473:2003 13.3.5.6 and NPG [Several contributors, 2006] performed in *Appendix D*, gives the following shear force capacity for the SFRC section;

$$V_d = V_{cd} + V_{fd} = \underline{675.3} > V\gamma$$

As seen above, the total shear force capacity of the foundation is larger than the design shear force affecting the slab, and consequently, there is no requirement for additional shear reinforcement.

4.4 Design and construction with fibres as sole reinforcement

4.4.1 Foundations

The calculations of the current foundation with fibres as sole reinforcement are shown in *Appendix E*. Due to NPG [Several contributors, 2006], the total moment capacity of the current foundation made of SFRC is:

$$M_{fd} = \underline{6760} \cdot v_f \text{ [kNm/m]}$$

By requiring the moment capacity to exceed the design moment, the following volume of steel fibres is necessary;

$$v_f \geq \underline{2.38} \text{ vol.-%}$$

Hence, with a fibre content more than 2.38 vol.-%, no additional conventional bar reinforcement is required.

In *Chapter 4.3.2* it was found that with a fibre content of 1 vol.-%, no shear reinforcement was required. Consequently, no shear reinforcement is required with a fibre content equal to, or more than, 2.38 vol.-%.

The design of the current foundation with fibres as sole reinforcement requires a necessary steel fibre content equal to 2.4 vol.-%.

4.4.2 Walls

The basement walls are subjected to a combination of bending and axial forces, and as described in *Chapter 3.2.3.2*, the design of the cross-section is to be performed according to an M-N diagram. An M-N diagram for the current wall is established in an Excel spreadsheet by defining 7 different failure situations for the cross-section. The shape of the M-N diagram is also dependent on the amount of reinforcement bars in the cross-section, as well as the residual strength of the steel fibre volume. The amount of reinforcement bars is set to 0, and the residual strength of the steel fibre is varied until the boundaries of the M-N diagram enclose the given load situation.

For the current cross-section and load situation, the M-N diagram gives the following necessary residual strength;

$$f_{tk,res} = 2.2 \text{ N/mm}^2$$

For the current wall, calculations given in *Appendix E* show a required fibre volume;

$$v_f \geq \underline{1.3} \text{ vol.-%}$$

Hence, with a fibre content more than 1.3 vol.-%, no additional conventional bar reinforcement is required.

The designing and constructing of the current wall with fibres as sole reinforcement requires a necessary steel fibre content equal to 1.3 vol.-%.

4.4.3 Columns

Analogous to the basement walls, also the basement columns are subjected to a combination of bending and axial forces, and hence, the design of the cross-section is to be performed according to an M-N diagram. In the M-N-diagram established in *Chapter 4.2.3*, the amount of reinforcement bars is set to 0, and the residual strength of the steel fibre is then varied until the boundaries of the M-N diagram enclose the given load situation.

The M-N diagram in *Appendix E* shows that it is not possible to design and construct the current column for the given load situation with fibres as sole reinforcement. The column is

subjected to such large axial compression forces, that compression bar reinforcement is necessary regardless of increased steel fibre volume content.

4.4.4 Slabs

The calculations of the current slab with fibres as sole reinforcement are shown in *Appendix E*. Due to NPG [Several contributors, 2006], the total moment capacity of the current slab made of SFRC can be expressed as:

$$M_{fd} = \underline{1650 \cdot v_f} \text{ [kNm/m]}$$

By requiring the moment capacity to exceed the design moment, the following volume of steel fibres is necessary;

$$v_f \geq \underline{5.2} \text{ vol.-%}$$

Hence, with a fibre content more than 5.2 vol.-%, no additional conventional bar reinforcement is required.

In *Chapter 4.3.5*, it was found that with a fibre content of 1 vol.-%, no shear reinforcement was required. Consequently, no shear reinforcement is required with a fibre content equal to, or more than, 5.2 vol.-%.

The designing and constructing of the current slab with fibres as sole reinforcement requires a necessary steel fibre content equal to 5.2 vol.-%.

4.5 Comparison

4.5.1 Foundations

Table 4.7 summarizes the resulting reinforcement requirements for the current foundation for the three different design approaches. The table shows that when adding 1 vol.-% steel fibres to the concrete, the required bar reinforcement for the current foundation is reduced with 42%, and at the same time, the requirement for shear reinforcement disappears. The design and construction of the current foundation with fibres as sole reinforcement requires a necessary steel fibre content equal to 2.4 vol.-%.

Table 4.7: Foundation reinforcement requirements for the three different design approaches

	Conventional reinforcement	1 vol.-% steel fibre and bar reinforcement	Sole steel fibre
Longitudinal bar reinforcement [mm ²]	3319	1917	0
Shear reinforcement at section <i>d</i> [mm ²]	2396	0	0
Volume ratio steel fibre [vol.-%]	0	1	2.4

Figure 4.2 shows the fibre and bar reinforcement necessary for the different design approaches over a foundation height variation for the current foundation. The foundation area is 2.7·2.7m², the design load is 1629 kN, and the allowed design sole pressure is 250N/mm². The current figure shows that for a fibre volume ratio equal to 1%, a foundation height of 620 mm is required to avoid conventional bar reinforcement. For comparison, with a fibre volume ratio equal to 2%, a foundation height of 440 mm is required to avoid conventional bar reinforcement.

Figure 4.2: Fibre and bar reinforcement over a foundation height variation.

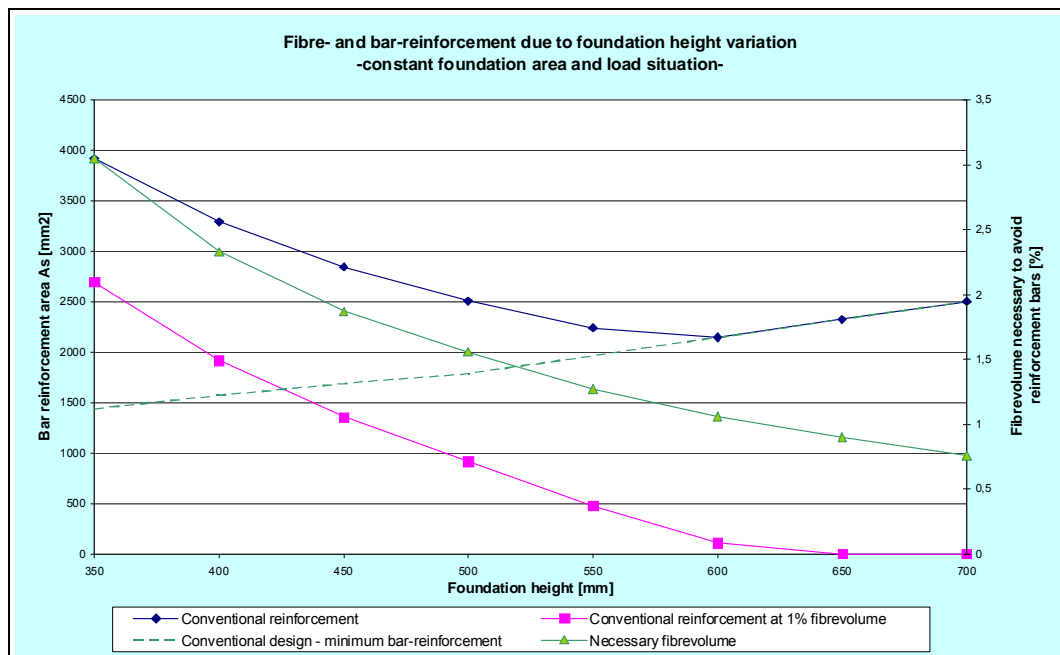
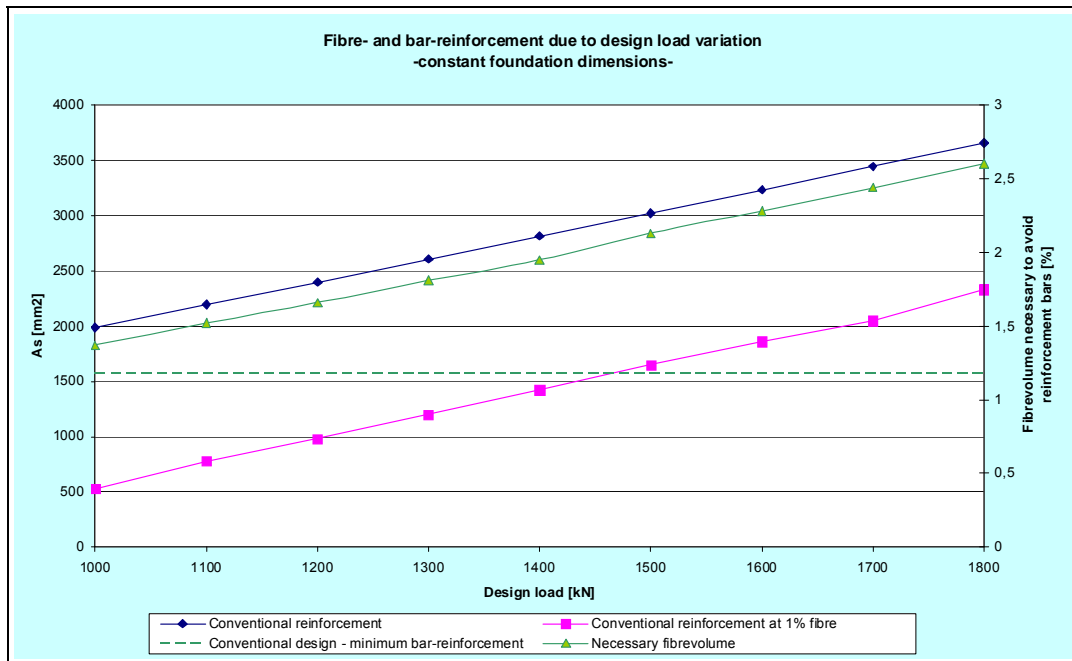

Figure 4.3 shows the reinforcement necessary, due to the different design approaches over a design load variation for the current foundation.

Figure 4.3: Fibre and bar reinforcement over a design load variation.



4.5.2 Walls

Table 4.8 summarizes the resulting reinforcement requirements for the current wall for the three different design approaches. The table shows that when adding 1 vol.-% steel fibres to the concrete, the required vertical bar reinforcement for the current wall is reduced with 77%. At the same time, the requirement for horizontal reinforcement disappears. The design and construction of the current wall with fibres as sole reinforcement requires a necessary steel fibre content equal to 1.3 vol.-%.

Table 4.8: Wall reinforcement requirements for the three different design approaches

	Conventional reinforcement	1 vol.-% steel fibre and bar reinforcement	Sole steel fibre
Vertical bar reinforcement [mm ²]	650	150	-
Horizontal bar reinforcement [mm ²]	389	-	-
Volume ratio steel fibre [vol.-%]	-	1	1.3

4.5.3 Columns

Table 4.9 summarizes the resulting reinforcement requirements for the current column for the three different design approaches. The table shows that when adding 1 vol.-% steel fibres to the concrete, the required bar reinforcement for the current column is reduced with 52%. The main reason for this considerable reduction is the lack of requirements for minimum bar reinforcement when it comes to steel fibre reinforced columns in the NPG for SFRC [Several

contributors, 2006]. Design and construction of the current column with fibres as sole reinforcement is not possible due to the large axial compression forces. A possible approach is to increase the column dimensions and let the concrete carry the compression forces.

Table 4.9: Column reinforcement requirements for the three different design approaches

	Conventional reinforcement	1 vol.-% steel fibre and bar reinforcement	Sole steel fibre
Vertical bar reinforcement [mm ²]	1050	500	-
Volume ratio steel fibre [vol.-%]	-	1	-

4.5.4 Slabs

Table 4.10 summarizes the resulting reinforcement requirements for the current slab for the three different design approaches. The table shows that when adding 1 vol.-% steel fibres to the concrete, the required bar reinforcement for the current slab is reduced with 20%. The design and construction of the current slab with fibres as sole reinforcement requires a necessary steel fibre content equal to 5.2 vol.-%.

Table 4.10: Slab reinforcement requirements for the three different design approaches

	Conventional reinforcement	1 vol.-% steel fibre and bar reinforcement	Sole steel fibre
Longitudinal bar reinforcement [mm ²]	1511	1220	-
Shear reinforcement at section <i>d</i> [mm ²]	251	-	-
Volume ratio steel fibre [vol.-%]	-	1	5.2

References

British Standards Institution, BS EN 1992, *Eurocode 2, Design of concrete structures*, Part 1-1: *General rules and rules for buildings*. BSI, London, 2004.

Concrete society (2007): *Guidance for the Design of Steel-Fibre-Reinforced Concrete*, Technical Report No. 63. The Concrete Society, UK, Camberley, March 2007.

Døssland, Åse Lyslo (2008): *Fibre Reinforcement in Load Carrying Concrete Structures*. PhD Thesis. The Norwegian University of Science and Technology (NTNU), Trondheim, Norway, 2008.

Jansson, Anette (2008): *Fibres in reinforced concrete structures – analysis, experiments and design*. Thesis for the degree of licentiate. Chalmers University of Technology, Göteborg, Sweden, 2008.

NS3473 Norges Standardiseringsråd (2003): *Prosjektering av betongkonstruksjoner. Beregnings og konstruksjonsregler*. (In Norwegian). Norwegian Standards Institution, 2003.

NS3490 Norges Standardiseringsråd (2004): *Prosjektering av konstruksjoner. Krav til pålitelighet*. (In Norwegian). Norwegian Standards Institution, 2004.

RILEM TC 162-TDF (2003): *Test and design methods for steel fibre reinforced concrete. s-e design method Final Recommendation*. (Chairlady L. Vanderwalle). Materials and Structures 36, pp. 560-567.

Sletten, Ove (2001): *Flatedekke, Versjon 3.6*. (In Norwegian). Ove Sletten, Trondheim.

Thorenfeldt E., Fjeld S., et. al (2006): *Stålfiberarmering I betong. Veiledning for prosjektering, utførelse og kontroll*. (In Norwegian) Draft, 2006. In this report referred to as the 'Norwegian preliminary guideline'.

Vikan, Hedda (2007): *COIN – Concrete Innovation Centre; Concrete workability and fibre content*. SINTEF report no. SBF BK A07029, 2007.

Appendix

- APPENDIX A, THEORETICAL MODEL FOR FIBRE ORIENTATION**
- APPENDIX B, MINIMUM REQUIRED BAR REINFORCEMENT**
- APPENDIX C, CALCULATIONS – TRADITIONAL DESIGN**
- APPENDIX D, CALCULATIONS – MANAGEABLE FIBRE CONTENT**
- APPENDIX E, CALCULATIONS – SOLE FIBRE REINFORCEMENT**
- APPENDIX F, CALCULATIONS – DESIGN MOMENT, SLAB**

APPENDIX A, THEORETICAL MODEL FOR FIBRE ORIENTATION

In this report, the theoretical model for fibre orientation according to [Thorenfeldt, 2003] is used.

In figure A1, the horizontal plane represents an area of the crack plane, while the hemisphere represents the directions in which the fibres will be evenly distributed if isotropic conditions are assumed [Døssland, 2008]. A fibre fraction with the angle $(\phi \pm \Delta\phi/2)$ is given as the relation between the area of the ring bounded by the angle $(\phi \pm \Delta\phi/2)$ on the surface in figure A1 and the total area of the hemisphere $2\pi r^2$ [Thorenfeldt, 2003];

$$(2\pi r \sin \phi \cdot r \Delta\phi) / 2\pi r^2 = \sin \phi \cdot \Delta\phi \quad (\text{Eq. A-1})$$

The corresponding volume ratio for the current fibre fraction with an angle $(\phi \pm \Delta\phi/2)$ is consequently;

$$v_{f\Delta\phi} = v_f \sin \phi \cdot \Delta\phi \quad (\text{Eq. A-2})$$

where v_f is the total fibre volume ratio.

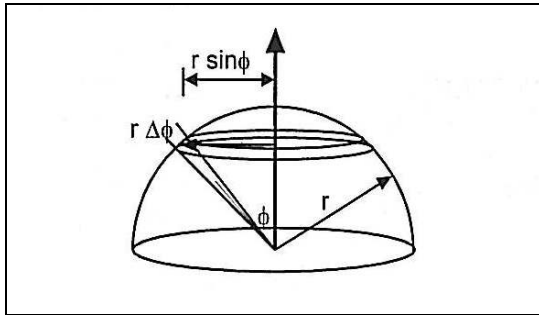

Figure A1. Directional model for fibres evenly distributed in all directions.

The section ratio, ρ , of a concrete cross-section is defined as the area of fibres per unit concrete area. Figure A2 illustrates subgroups of fibres with equal angle ϕ to a unit concrete section normal. For an isotropic fibre distribution, the section ratio is found by integrating all fibres with a direction angle between 0 and $\pi/2$;

$$\rho_x = v_f \int \sin \phi \cos \phi d\phi = v_f [(1/2) \sin^2 \phi] = v_f / 2 \quad (\text{Eq. A-3})$$

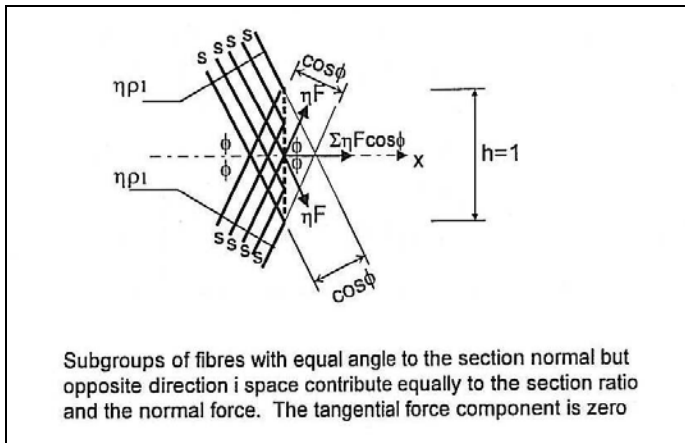

Figure A2. Subgroups of fibres with equal angle ϕ to a unit concrete section normal.

Due to figure A3, the normal force resultant (plastic) is found to be;

$$F_{xp} / A_c = v_f \sigma_F \int \sin \phi \cos^2 \phi d\phi = -v_f \sigma_F \left[\cos^3 \phi / (2 + 1) \right] = v_f \sigma_F / 3 \quad (\text{Eq. A-4})$$

Consequently, if the fibre orientation is isotropic, the section ratio in each direction is $\rho_1 = \rho_2 = \rho_3 = v_f / 2$, with a corresponding plastic normal force resultant per unit concrete area equal to $F_{xp} / A_c = v_f \cdot \sigma_F / 3$, where $v_f = V_f / V_c$ is the fibre volume ratio, F_{xp} is the plastic normal force resultant in the given direction, A_c is the cross-section of the concrete in the given direction, and σ_F is the stress in the steel-fibres.

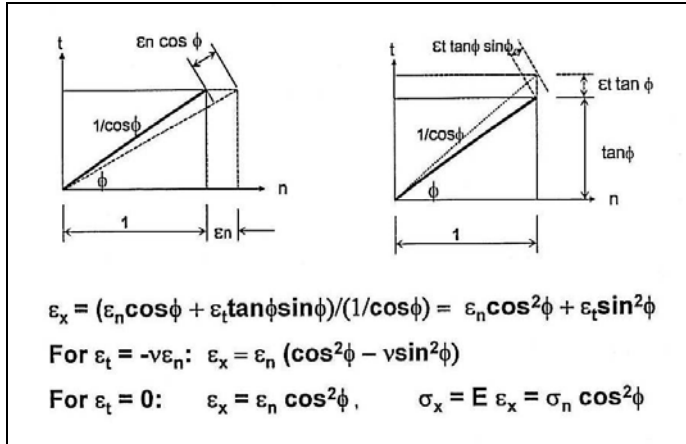

Figure A3. Strain in fibre with direction angle ϕ to the principal strain direction.

If fibres are horizontally orientated in plane 1-2, the section ratio is found by integrating all fibres with a direction angle between 0 and $\pi/2$;

$$\rho_{x2} = v_f \int \cos \phi d\phi / \int d\phi = v_f [\sin \phi] / [\phi] = 0,637 v_f \quad (\text{Eq. A-5})$$

with a corresponding normal force resultant (plastic) equal to;

$$F_{xp2} / A_c = v_f \sigma_F \int \cos^2 \phi d\phi / \int d\phi = v_f \sigma_F [\phi / 2 + (1/4) \sin 2\phi] / [\phi] = v_f \sigma_F / 2 \quad (\text{Eq. A-6})$$

Hence, if fibres are horizontally orientated in plane 1-2, the section ratio in the two directions will be $\rho_1 = \rho_2 = (2/\pi) \cdot v_f = 0.64 v_f$ ($\rho_3 = 0$) with a corresponding plastic normal force resultant per unit concrete area equal to $F_{xp2} / A_c = v_f \cdot \sigma_f / 2$.

If all fibres are uniformly directed, the share of fibres in this direction would be $\rho_1 = v_f$ ($\rho_2 = \rho_3 = 0$), with a corresponding plastic normal force resultant per unit concrete area equal to $F_{xp1} / A_c = v_f \cdot \sigma_f$.

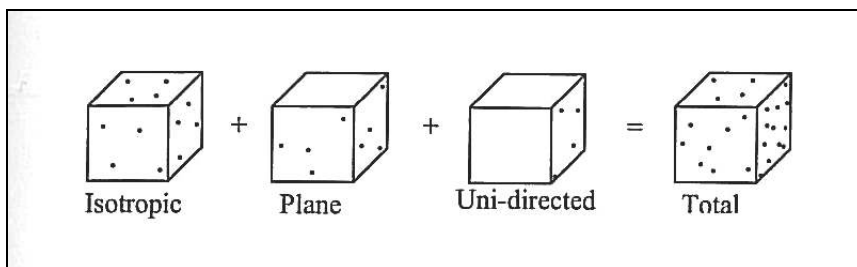

Figure A4. Share of fibres in each direction [Døssland, 2008].

APPENDIX B, MINIMUM REQUIRED REINFORCEMENT

The minimum area of reinforcement required to develop multiple cracking in reinforced concrete tension members is found by equating the yield capacity of the reinforcement to the cracking load. If less reinforcement than the specified minimum area of reinforcement is provided, only a single crack forms. For SFRC, the minimum area of reinforcement, as well as the crack widths, are reduced by the fibres that bridge cracks, and, consequently, increase the residual tensile stress in the concrete after cracking.

Sections without conventional reinforcement

Immediate before cracking, the cross-section shown in figure B1 will be in the following stress situation;

$$\sigma = \frac{M_{cr}}{W_{el}} = f_{tk} \Rightarrow M_{cr} = W_{el} \cdot f_{tk} = \frac{bh^2}{6} \cdot f_{tk} \quad (\text{Eq. B-1})$$

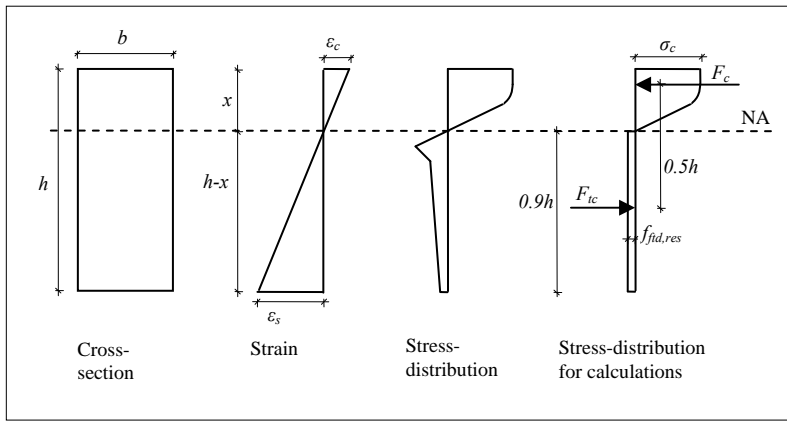

Figure B1. Strain and stress distribution over a steel-fibre reinforced concrete cross-section.

After cracking, the stress situation of the cross-section is;

$$M_{steel} = f_{f_{tk,res}} \cdot h_{tension} \cdot b \cdot z = f_{f_{tk,res}} \cdot 0.9hb \cdot 0.5h \quad (\text{Eq. B-2})$$

Immediate before cracking, the capacity of the steel fibres just exceeds the tension in the concrete;

$$f_{f_{tk,res}} \cdot 0.9hb \cdot 0.5h > \frac{bh^2}{6} \cdot f_{tk} \quad (\text{Eq. B-3})$$

By inserting the expression for the residual stress in Eq. B-3, an expression describing the minimum amount of fibres necessary to avoid uncontrolled cracking of the cross-section is derived;

$$\eta_0 v_f \sigma_{f_{t,mid}} \cdot 0.9hb \cdot 0.5h > \frac{bh^2}{6} \cdot f_{tk}$$

$$v_f > \frac{1}{6} \cdot bh^2 f_{tk} \cdot \frac{1}{\eta_0 \sigma_{f_{t,mid}} 0.45bh^2}$$

$$v_f > 0.37 \frac{f_{tk}}{\eta_0 \sigma_{f_{t,mid}}} \quad (\text{Eq. B-4})$$

Sections with conventional reinforcement

For sections with conventional reinforcement as well as steel fibres, the cross-section's moment capacity is set to be the sum of the capacity contribution from the bar reinforcement and the steel fibres. To avoid cracks, this capacity is to be larger than the crack moment.

$$M_{cr} \leq M_{bar} + M_{fibre} \quad (\text{Eq. B-5})$$

By assuming the same stress situation as described above, the inner level arm for the two different reinforcements are as follows;

$$z_{bar} = \frac{2}{6}h + \frac{2}{6}h = \frac{2}{3}h \quad z_{fibre} = 0.5h \quad (\text{Eq. B-6})$$

Consequently, the minimum bar reinforcement required is as follows;

$$A_s f_{sk} z_{bar} + 0.9bh f_{f_{tk,res}} z_{fibre} \geq \frac{1}{6}bh^2 f_{tk}$$

$$A_s f_{sk} \frac{2}{3}h + 0.45bh^2 f_{f_{tk,res}} \geq \frac{1}{6}bh^2 f_{tk}$$

$$A_s \geq \frac{\frac{1}{6}bh^2 f_{tk} - 0.45bh^2 f_{f_{tk,res}}}{f_{sk} \frac{2}{3}h} = \frac{0.25bh f_{tk} - 0.675bh f_{f_{tk,res}}}{f_{sk}}$$

$$A_s \geq 0.25bh \left(\frac{f_{tk} - 2.7 f_{f_{tk,res}}}{f_{sk}} \right) \quad (\text{Eq. B-7})$$

APPENDIX C, CALCULATIONS – TRADITIONAL DESIGN

- 1.1 FOUNDATIONS 2
 - 1.1.1 *Design* 2
 - 1.1.2 *Design by program; ‘Ove Sletten’* 4
- 1.2 WALLS 5
- 1.3 COLUMNS 7
- 1.4 SLABS 8

1.1 Foundations

1.1.1 Design

The foundation's moment capacity is:

$$M_{cd} = K \cdot f_{cd} \cdot b \cdot d^2$$

where

$$K = 0.275$$

$$f_{cd} = f_{cn} / \gamma_c = 23.8 / 1.4 = 17.0 \text{ N/mm}^2$$

$$d = 344 \text{ mm}$$

$$M_{cd} = 0.275 \cdot 17.0 \cdot 1000 \cdot 344^2 = \underline{553.2} \text{ kNm/m}$$

In *Chapter 4.1.4.2*, the design moment in the critical section of the foundation is found to be;

$$M_\gamma = \underline{160.8} \text{ kNm/m}$$

The necessary bar reinforcement area for the foundation is given as:

$$A_s = \frac{M_\gamma}{f_{sd} \cdot z}$$

where z , the inner level arm of the section, is defined as;

$$z = \left(1 - c \cdot \frac{M_\gamma}{M_{cd}}\right) \cdot d$$

For concrete quality B30 and reinforcement quality B500C, c can be set to 0.17:

$$z = \left(1 - c \cdot \frac{M_\gamma}{M_{cd}}\right) \cdot d = \left(1 - 0.17 \cdot \frac{160.8}{553.2}\right) \cdot 344 = \underline{327} \text{ mm}$$

Necessary longitudinal bar reinforcement per meter in each direction of the foundation is:

$$A_s = \frac{M_\gamma}{f_{sd} \cdot z} = \frac{160.8}{400 \cdot 327} = \underline{1229} \text{ mm}^2/\text{m}$$

The total bar reinforcement required for the foundation is consequently:

$$A_s = 1229 \cdot 2.7 = \underline{3319} \text{ mm}^2$$

From NS 3473:2003 18.6.2, the minimum required bar reinforcement is given as;

$$A_{s,\min} \geq 0.25k_w A_c f_{tk} / f_{sk}$$

$$A_{s,\min} \geq 0.25 \cdot 1.1 \cdot 2700 \cdot 400 \cdot 1.8 / 500$$

$$A_{s,\min} \geq \underline{1069} \text{ mm}^2$$

$$A_s \geq A_{s,\min}$$

17 $\emptyset 16$ gives a bar reinforcement area equal to $A_s = 3418 \text{ mm}^2$

The foundation's capacity for shear along its critical section, at distance d from the edge of column, is given by NS 3473:2003 13.3.5.6:

$$V_{cd,d} = 0.3 \cdot \left(f_{td} + \frac{k_A \cdot \rho}{\gamma_c} \right) \cdot d \cdot k_v \leq 0.6 \cdot f_{td} \cdot d \cdot k_v$$

where

$$f_{td} = f_m / \gamma_c = 1.8 / 1.4 = 1.29 \text{ N/mm}^2$$

$$k_A = 100 \text{ N/mm}^2$$

$$d = 344 \text{ mm}$$

$$\rho = A_s / (b \cdot d) = 3418 / (2700 \cdot 344) = 0.0037$$

$$\gamma_c = 1.4$$

$$k_v = 1.5 - d / d_1 = 1.5 - 0.344 = 1.156$$

$$V_{cd,d} = 0.3 \cdot \left(1.29 + \frac{100 \cdot 0.0037}{1.4} \right) \cdot 344 \cdot 1.156 \leq 0.6 \cdot 1.29 \cdot 344 \cdot 1.156$$

$$V_{cd,d} = \underline{185.4} \leq 307.8 \text{ kN/m}$$

Total shear force capacity of the concrete along the critical section, at distance d from the column edge, is;

$$V_{cd,d} = 185.4 \cdot ((0.3 + 2 \cdot 0.344) \cdot 4) = \underline{732.7} \text{ kN}$$

The shear force capacity of the concrete causes a requirement for shear reinforcement equal to;

$$V_{sd,d} = V_{\gamma,d} - V_{cd,d} = 1410.5 - 732.7 = 677.8 = \sum f_{sd} A_{sv,d} \sin \alpha$$

$$\alpha = 45$$

$$\sum f_{sd} A_{sv,d} \sin \alpha = 677.8$$

$$\sum A_{sv,d} = \frac{677800}{400 \cdot \sin 45} = \underline{2396} \text{ mm}^2$$

8 $\emptyset 10$ reinforcement bars with a 45° inclination angle, on each side along the critical section, are chosen. This gives a total shear reinforcement equal to $(4 \cdot 8 \emptyset 10) = 2513 \text{ mm}^2$.

Total shear force capacity of the concrete at distance $2d$ from the column edge, is;

$$V_{cd,2d} = 168.5 \cdot ((0.3 + 4 \cdot 0.344) \cdot 4) = \underline{1129.6} \text{ kN}$$

The design shear force at the same section is 1001 kN, i.e. lower than the shear capacity. Therefore, there is no requirement for shear reinforcement at section $2d$ from the edge of the column.

1.1.2 Design by program; 'Ove Sletten'

Calculations in the concrete program Ove Sletten, *figure C1 - C2*, estimates a longitudinal bar reinforcement in the lower edge of the foundation equal to 17Ø16, and shear reinforcement with a 45° inclination angle in the critical section at the distance d from the column equivalent to 8Ø10.

Figure C1; Loads applied for calculations in Ove Sletten

Belastning i overkant av fundament. Lasttilfelle nr 1			
Permanent last		Variabel last	
Mg_y	0,0 kNm	Mp_y	0,0 kNm
Mg_z	0,0 kNm	Mp_z	0,0 kNm
Vg_y	0,0 kN	Vp_y	0,0 kN
Vg_z	0,0 kN	Vp_z	0,0 kN
Ng	-864,0 kN	Np	-425,0 kN

Langtidsandel av nyttelast: 0,40

Positiv moment-og kraftvektorer i Y og Z-retning. Positiv Ng og Np peker oppover.

Figure C2; Foundation bar reinforcement in the Ultimate Limit State due to Ove Sletten

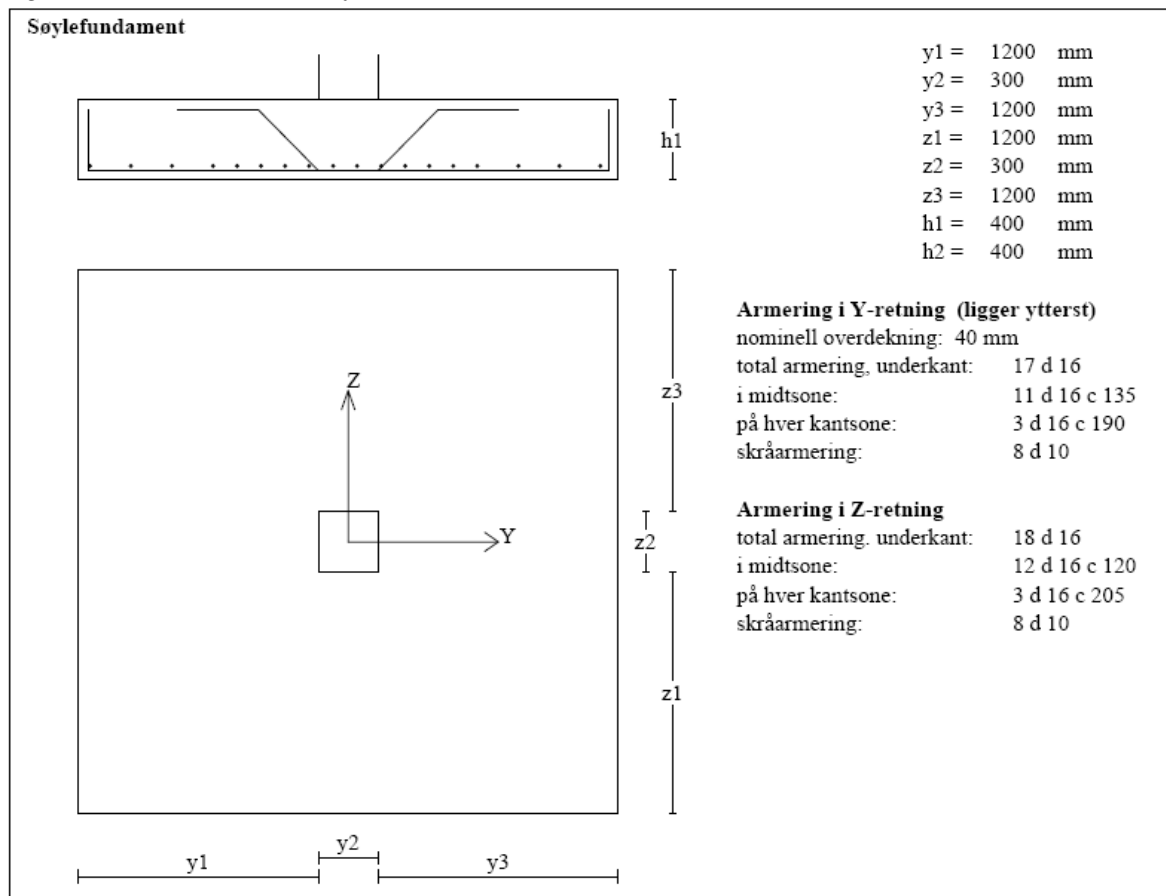

1.2 Walls

The basement walls are subjected to a combination of bending and axial forces defined in *Chapter 4.1.4.3*;

$$\text{Moment – L1; } M_{\gamma L1} = \underline{22.4} \text{ kNm/m}$$

$$\text{Vertical load – L1; } N_{\gamma L1} = \underline{135.7} \text{ kN/m}$$

$$\text{Moment – L2; } M_{\gamma L2} = \underline{22.2} \text{ kNm/m}$$

$$\text{Vertical load – L2; } N_{\gamma L2} = \underline{72.0} \text{ kN/m}$$

The design of the walls is to be performed according to an M-N diagram. An M-N diagram for the current wall is established in an Excel spreadsheet by defining 7 different failure situations for the cross-section. The shape of the M-N diagram is also dependent on the amount of reinforcement bars in the cross-section, and hence the reinforcement bar amount is varied in the Excel spreadsheet until the boundaries of the M-N diagram enclose the current load situation.

The total reinforcement bar areas necessary for the current cross-section and load situations are;

$$\text{Load situation L1, figure C3; } A_{sL1} = \underline{500} \text{ mm}^2/\text{m}$$

$$\text{Load situation L2, figure C4; } A_{sL2} = \underline{650} \text{ mm}^2/\text{m}$$

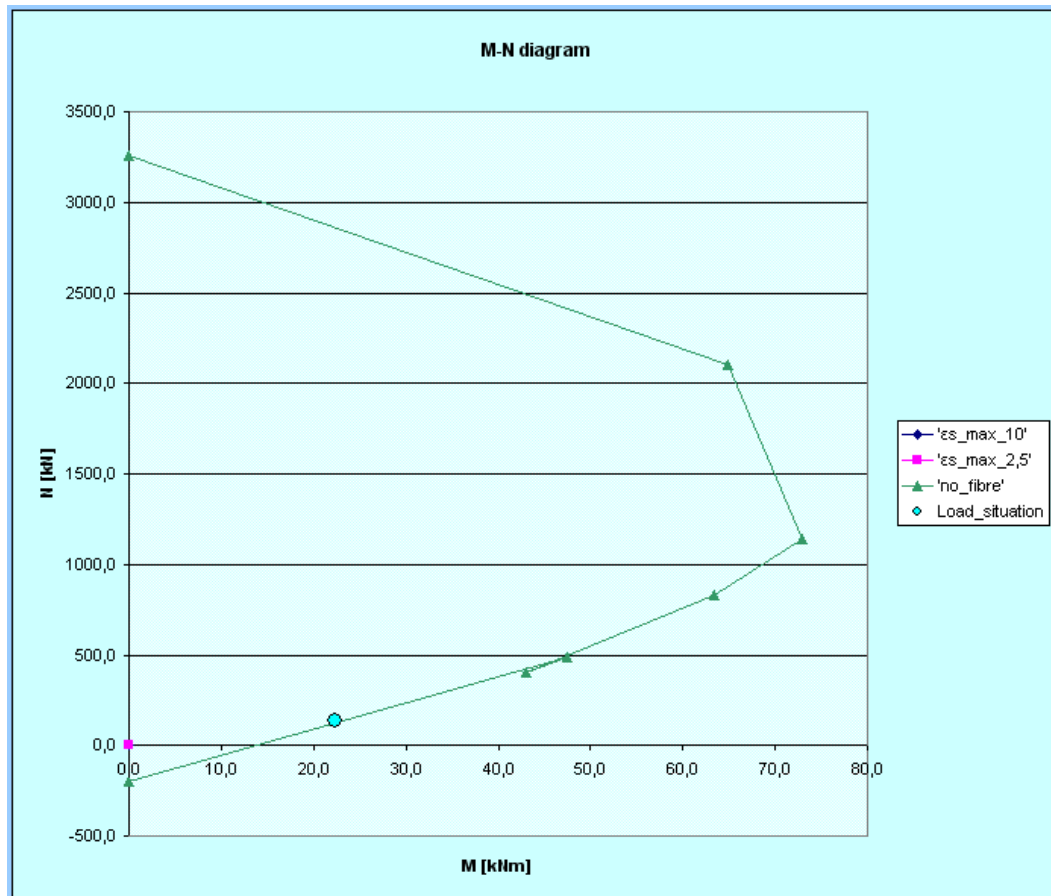

Figure C3; M-N diagram, basement wall with 250+250mm²/m bar reinforcement.

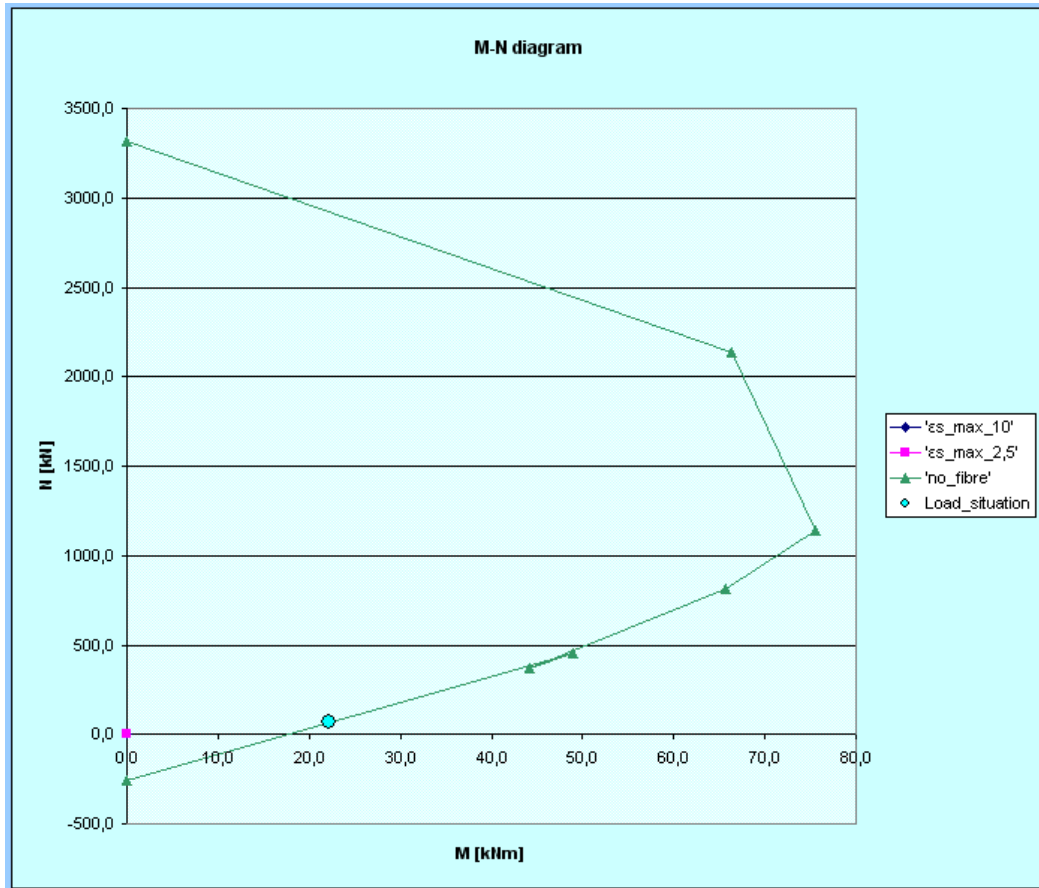

Figure C4; M-N diagram, basement wall with 325+325mm²/m bar reinforcement.

NS3473:2003 defines the following required minimum amount of vertical reinforcement for walls;

$$A_{s,\min} \geq 0.3A_c f_{tk} / f_{sk}$$

$$A_{s,\min} \geq 0.3 \cdot 180 \cdot 1000 \cdot 1.8 / 500$$

$$A_{s,\min} \geq \underline{194.4} \text{ mm}^2$$

$$A_s > A_{s,\min}$$

Vertical reinforcement $\emptyset 10c240$ on the outer as well as the inner side of the wall gives a total bar-reinforcement area equal to $A_s = 654 \text{ mm}^2/\text{m}$.

NS3473:2003 defines the following required minimum amount of horizontal reinforcement for walls;

$$A_{s,\min} \geq 0.6A_c f_{tk} / f_{sk}$$

$$A_{s,\min} \geq 0.6 \cdot 180 \cdot 1000 \cdot 1.8 / 500$$

$$A_{s,\min} \geq \underline{388.8} \text{ mm}^2$$

Horizontal reinforcement $\emptyset 8c300$ on the outer as well as the inner side of the wall gives a total bar-reinforcement area equal to $A_s = 402 \text{ mm}^2/\text{m}$.

The basement wall's capacity for shear along its critical section, at the lower edge at the wall, is given by NS 3473:2003 13.3.2.1:

$$V_{cd,d} = 0.3 \left(f_{td} + \frac{k_A A_s}{\gamma_c b_w d} \right) b_w d k_v \leq 0.6 f_{td} b_w d k_v$$

where

$$f_{td} = f_m / \gamma_c = 1.8 / 1.4 = 1.29 \text{ N/mm}^2$$

$$k_A = 100 \text{ N/mm}^2$$

$$d = 140 \text{ mm}$$

$$A_s = 419 \text{ mm}^2/\text{m}$$

$$\gamma_c = 1.4$$

$$b_w = 1000 \text{ mm}$$

$$k_v = 1.5 - d / d_1 = 1.5 - 0.140 = 1.36$$

$$V_{cd,d} = 0.3 \cdot \left(1.29 + \frac{100 \cdot 419}{1.4 \cdot 1000 \cdot 140} \right) \cdot 1000 \cdot 140 \cdot 1.36 \leq 0.6 \cdot 1.29 \cdot 140 \cdot 1000 \cdot 1.36$$

$$V_{cd,d} = \underline{85.9} \leq 147.4 \text{ kN/m}$$

$$V_{cd,d} = 85.9 \geq (P_\gamma + P_q)$$

Total shear force capacity of the concrete along the critical section, at the lower edge at the wall, is sufficient to carry the external horizontal forces.

1.3 Columns

From *Chapter 4.1.4.4*, the basement columns are subjected to a combination of bending and axial forces;

Moment; $M_\gamma = \underline{32.6} \text{ kNm/m}$

Vertical load; $N_\gamma = \underline{1629} \text{ kN/m}$

Analogous to the basement walls, also the basement columns are subjected to combined moment and axial forces, and hence the design is to be performed according to an M-N diagram. An M-N diagram for the current column is established in an Excel spreadsheet by defining 7 different failure situations for the cross-section. The shape of the M-N diagram is also dependent on the amount of reinforcement bars in the cross-section, and hence the reinforcement bar amount is varied in the Excel spreadsheet until the boundaries of the M-N diagram enclose the current load situation.

The M-N diagram in *figure C5* shows that the total reinforcement bar area necessary for the current cross-section and load situation is;

$$A_s = \underline{500} \text{ mm}^2$$

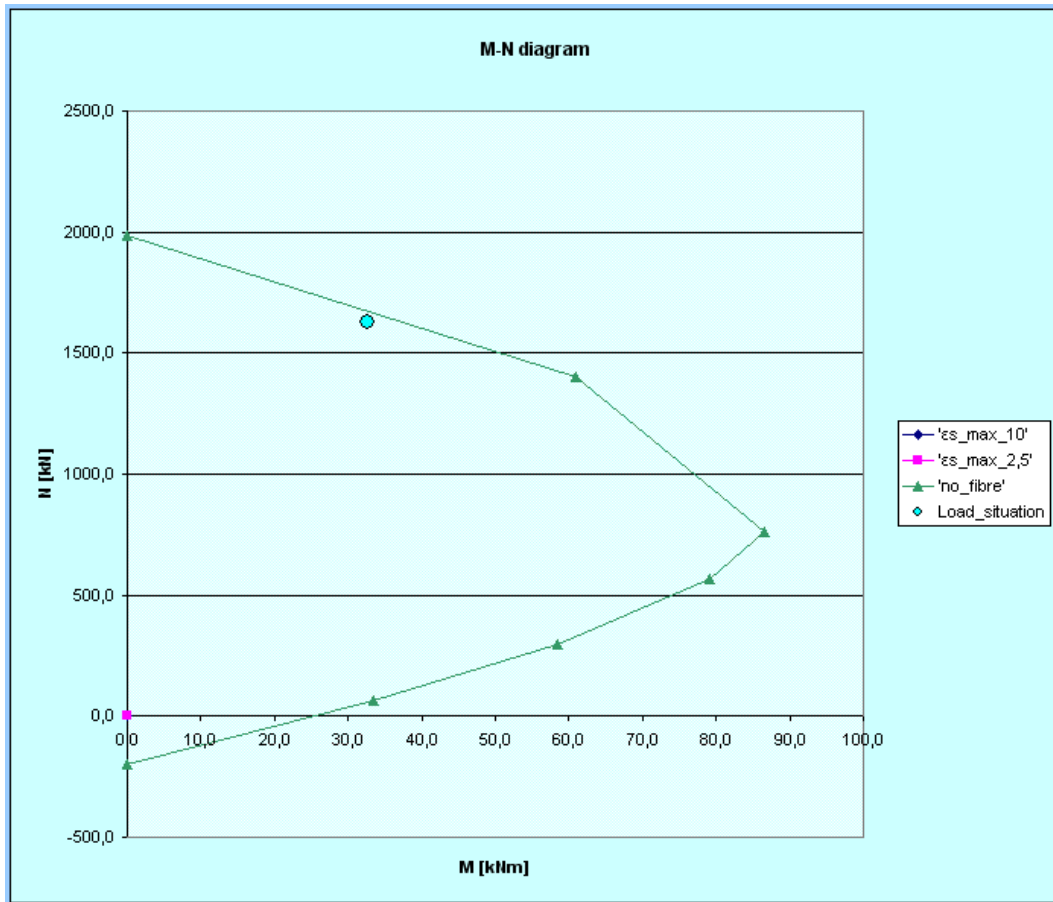

Figure C5: M-N diagram, column with 250+250mm²/m bar reinforcement..

NS3473:2003 defines the following required minimum amount of reinforcement for columns;

$$A_{s,\min} \geq \max\langle 0.01A_c \mid 0.2A_c f_{cn} / f_{sk} \rangle$$

$$A_{s,\min} \geq \max\langle 0.01 \cdot 300 \cdot 350 \mid 0.2 \cdot 300 \cdot 350 \cdot 23.8 / 500 \rangle$$

$$A_{s,\min} \geq \max\langle 1050 \mid 1000 \rangle$$

$$A_{s,\min} \geq 1050 \text{ mm}^2$$

$$A_s < A_{s,\min}$$

6ø16 gives a bar-reinforcement-area equal to $A_s = 1206 \text{ mm}^2$

1.4 Slabs

The slab's moment capacity is:

$$M_{cd} = K \cdot f_{cd} \cdot b \cdot d^2$$

where

$$K = 0.275$$

$$f_{cd} = f_{cn} / \gamma_c = 23.8 / 1.4 = 17.0 \text{ N/mm}^2$$

$$b = 1000 \text{ mm}$$

$$d = 160 \text{ mm}$$

$$M_{cd} = 0.275 \cdot 17.0 \cdot 1000 \cdot 160^2 = \underline{119.7} \text{ kNm/m}$$

The design moment of the slab is as stated in *Chapter 4.1.4.5*;

$$M_\gamma = \underline{85.2} \text{ kNm/m}$$

The total necessary bar reinforcement area in the tension zone of the slab is given as:

$$A_s = \frac{M_\gamma}{f_{sd} \cdot z}$$

Where z , the inner level arm of the section, is defined as;

$$z = \left(1 - c \cdot \frac{M_\gamma}{M_{cd}}\right) \cdot d$$

For concrete quality B30 and reinforcement quality B500C, c can be set to 0.17:

$$z = \left(1 - c \cdot \frac{M_\gamma}{M_{cd}}\right) \cdot d = \left(1 - 0.17 \cdot \frac{85.2}{119.7}\right) \cdot 160 = \underline{141} \text{ mm}$$

Necessary longitudinal bar reinforcement in the slab's upper edge over the support is:

$$A_s = \frac{M_\gamma}{f_{sd} \cdot z} = \frac{85200000}{400 \cdot 141} = \underline{1511} \text{ mm}^2/\text{m}$$

NS3473:2003 defines the following required minimum amount of longitudinal reinforcement for slabs;

$$A_{s,\min} \geq 0.25 k_w A_c f_{tk} / f_{sk}$$

where $k_w = 1.5 - h/h_l$, where $h_l = 1.0\text{m}$ and $h = 0.2\text{m}$
 $k_w = 1.3$

$$A_{s,\min} \geq 0.25 \cdot 1.3 \cdot 200 \cdot 1000 \cdot 1.8 / 500$$

$$A_{s,\min} \geq \underline{234} \text{ mm}^2$$

$$A_s \geq A_{s,\min}$$

8ø16c130 gives a bar-reinforcement-area equal to $A_s = 1547 \text{ mm}^2/\text{m}$.

The slab's capacity for shear along its critical section, at distance d from the edge of column, is given by NS 3473:2003 13.3.5.6:

$$V_{cd,d} = 0.3 \cdot \left(f_{td} + \frac{k_A \cdot \rho}{\gamma_c}\right) \cdot d \cdot k_v \leq 0.6 \cdot f_{td} \cdot d \cdot k_v$$

where

$$f_{td} = f_m / \gamma_c = 1.8 / 1.4 = 1.29 \text{ N/mm}^2$$

$$k_A = 100 \text{ N/mm}^2$$

$$d = 160 \text{ mm}$$

$$\rho = A_s / (b \cdot d) = 1547 / (1000 \cdot 160) = 0.010$$

$$\gamma_c = 1.4$$

$$k_v = 1.5 - d / d_1 = 1.5 - 0.16 = 1.34$$

$$V_{cd,d} = 0.3 \cdot \left(1.29 + \frac{100 \cdot 0.010}{1.4}\right) \cdot 160 \cdot 1.34 \leq 0.6 \cdot 1.29 \cdot 160 \cdot 1.34$$

$$V_{cd,d} = \underline{128.9} \leq 165.9 \text{ kN/m}$$

Total shear force capacity of the concrete along the critical section, at distance d from the column edge, is;

$$V_{cd,d} = 128.9 \cdot ((0.3 + 2 \cdot 0.16) \cdot 2 + (0.4 + 2 \cdot 0.16) \cdot 2) = \underline{345.5} \text{ kN}$$

The shear force capacity of the concrete causes a requirement for shear reinforcement equal to;

$$V_{sd,d} = V_{\gamma,d} - V_{cd,d} = 416.6 - 345.5 = 71.1 = \sum f_{sd} A_{sv,d} \sin \alpha$$

$$\alpha = 45$$

$$\sum f_{sd} A_{sv,d} \sin \alpha = 71.1$$

$$\sum A_{sv,d} = \frac{71100}{400 \cdot \sin 45} = \underline{251} \text{ mm}^2$$

2 \emptyset 8 reinforcement bars with a 45° inclination angle, on each side along the critical section, are chosen. This gives a total shear reinforcement area equal to (4 \cdot 2 \emptyset 8) = 402mm².

Total shear force capacity of the concrete, at distance $2d$ from the column edge, is;

$$V_{cd,2d} = 128.9 \cdot ((0.3 + 4 \cdot 0.160) \cdot 2 + (0.4 + 4 \cdot 0.160) \cdot 2) = \underline{510.4} \geq V_{\gamma}$$

Consequently, there is no requirement for shear reinforcement at section $2d$ from the edge of the column.

APPENDIX D, CALCULATIONS – MANAGEABLE FIBRE CONTENT

1.1 GENERAL..... 2
1.2 FOUNDATIONS 2
1.3 WALLS 5
1.4 COLUMNS 6
1.5 SLABS..... 7

1.1 General

In this report, a manageable fibre content is defined to be a fibre volume fraction equal to 1%, which gives the following residual stress for the concrete;

$$f_{tk, res} = \eta_0 \cdot v_f \cdot \sigma_{fk, mid}$$

where

$$\eta_0 = 1/3$$

$$\sigma_{fk, mid} = 500 \text{ N/mm}^2$$

$$v_f = 1 \text{ vol.-%} = 0.01$$

$$f_{tk, res} = 0.333 \cdot 0.01 \cdot 500 = \underline{1.67} \text{ N/mm}^2$$

1.2 Foundations

According to the NPG [Several contributors, 2006], the total moment capacity of a rectangular section made of SFRC is defined as:

$$M_{fd} = 0.4 \cdot f_{fd, res} \cdot b \cdot h^2 \cdot p \cdot e$$

where

$$f_{fd, res} = \frac{f_{tk, res}}{\gamma_m} = \frac{1.67}{1.55} = 1.08 \text{ N/mm}^2$$

$$h = 400 \text{ mm}$$

$$p = 1.1 - 0.7 \cdot h \geq 0.75$$

$$p = 0.82$$

$$e = 1.2$$

$$M_{fd} = 0.4 \cdot 1.08 \cdot 1000 \cdot 400^2 \cdot 0.82 \cdot 1.2$$

$$M_{fd} = \underline{68.0} \text{ kNm/m}$$

In *Chapter 4.1.4.2*, the design moment in the critical section of the foundation is found to be;

$$M_\gamma = \underline{160.8} \geq M_{fd}$$

The moment capacity of the SFRC is not large enough to carry the design load, and accordingly, the foundation has to be reinforced with conventional reinforcement bars as well as steel fibre.

As described in *Chapter 3.2.3.2*, the moment capacity for the foundation in question, reinforced with both reinforcement bars and steel fibres, is determined as follows; For a given reinforcement situation, axial equilibrium over the cross-section is demanded, and with that the depth to the neutral axis is found. Further, the design moment of resistance is found by taking moments about the neutral axis. The tensile stress in the concrete is assumed to be f_{td} , including the steel fibres contribution to the cross-section's capacity. A spreadsheet performing the above described operation is established in Excel, and the amount of reinforcement bars is varied until the desired moment of resistance is reached. The spreadsheet results for the current foundation are shown in *figure D1*.

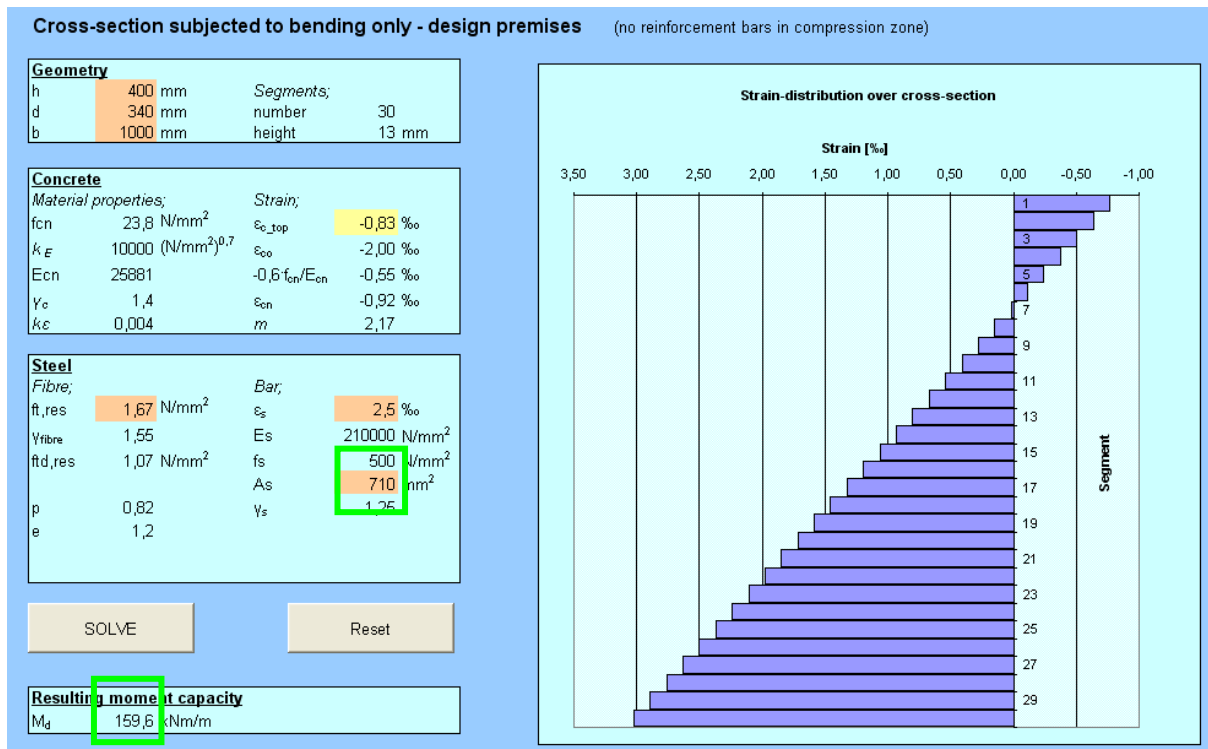

Figure D1: Required bar reinforcement when 1 vol.-% steel fibre content.

To obtain a moment of resistance equal to 160.8 kNm, the following amount of reinforcement bars is necessary;

$$A_s = 710 \text{ mm}^2/\text{m}$$

Consequently, the total necessary longitudinal bar reinforcement in the foundation is:

$$A_s = 710 \cdot 2.7 = 1917 \text{ mm}^2$$

For foundations containing reinforcement bars as well as steel fibres, the minimum required bar reinforcement is the same as for slabs, Chapter 3.2.4.1;

$$A_{s,\min} \geq 0.25k_w A_c (f_{tk} - 2.7 f_{tk,\text{res}}) / f_{sk}$$

$$A_{s,\min} \geq 0.25 \cdot 1.1 \cdot 2700 \cdot 400 \cdot (1.8 - 2.7 \cdot 1.67) / 500$$

$$A_{s,\min} \geq -1610 \text{ mm}^2$$

$$A_s \geq A_{s,\min}$$

10 ø16 gives a bar-reinforcement-area equal to $A_s=2010\text{mm}^2$

The foundation's capacity for shear along its critical section, at distance d from the edge of column, is defined as:

$$V_d = V_{cd} + V_{fd} + V_{sd}$$

where V_{cd} is the shear strength of the concrete

V_{fd} is the shear strength because of the steel fibre

V_{sd} is the shear strength because of conventional reinforcement

According to NS 3473:2003 13.3.5.6, the total shear force capacity of the concrete, in the critical section d from the column edge, is as follows:

$$V_{cd,d} = 0.3 \cdot \left(f_{td} + \frac{k_A \cdot \rho}{\gamma_c} \right) \cdot d \cdot k_v \leq 0.6 \cdot f_{td} \cdot d \cdot k_v$$

where

$$f_{td} = f_m / \gamma_c = 1.8 / 1.4 = 1.29 \text{ N/mm}^2$$

$$k_A = 100 \text{ N/mm}^2$$

$$d = 344 \text{ mm}$$

$$\rho = A_s / (b \cdot d) = 2011 / (2700 \cdot 344) = 0.0022$$

$$\gamma_c = 1.4$$

$$k_v = 1.5 - d / d_1 = 1.5 - 0.344 = 1.156$$

$$V_{cd,d} = 0.3 \cdot \left(1.29 + \frac{100 \cdot 0.0022}{1.4} \right) \cdot 344 \cdot 1.156 \leq 0.6 \cdot 1.29 \cdot 344 \cdot 1.156$$

$$V_{cd,d} = \underline{172.6} \leq 307.8 \text{ kN/m}$$

Total shear force capacity of the concrete along the critical section, at distance d from the column edge, is;

$$V_{cd,d} = 172.6 \cdot ((0.3 + 2 \cdot 0.344) \cdot 4) = \underline{682.1} \text{ kN}$$

According to the NPG [Several contributors, 2006], the steel fibres' contribution to the shear force capacity of the foundation is defined as:

$$V_{fd} = 0.8 \cdot f_{fd, res} \cdot b \cdot d \cdot p$$

$$V_{fd} = 0.8 \cdot 1.08 \cdot 1000 \cdot 344 \cdot 0.82 = \underline{234.7} \text{ kN/m}$$

$$V_{fd} = 234.7 \cdot ((0.3 + 2 \cdot 0.344) \cdot 4) = \underline{927.5} \text{ kN}$$

The total shear force capacity for the SFRC section is as follows;

$$V_d = V_{cd} + V_{fd} = 682.1 + 927.5 = \underline{1609.6} > V\gamma$$

As seen above, the total shear force capacity of the foundation is larger than the design shear force affecting the foundation, and consequently, there is no requirement for additional shear reinforcement.

1.3 Walls

The basement walls are subjected to a combination of bending and axial forces defined in *Chapter 4.1.4.3*;

$$\text{Moment – L1; } M_{\gamma L1} = \underline{22.4} \text{ kNm/m}$$

$$\text{Vertical load – L1; } N_{\gamma L1} = \underline{135.7} \text{ kN/m}$$

$$\text{Moment – L2; } M_{\gamma L2} = \underline{22.2} \text{ kNm/m}$$

$$\text{Vertical load – L2; } N_{\gamma L2} = \underline{72.0} \text{ kN/m}$$

As described in *Chapter 3.2.3.2*, the design of the cross-section is to be performed according to an M-N diagram. An M-N diagram for the current wall is established in an Excel spreadsheet by defining 7 different failure situations for the cross-section. The shape of the M-N diagram is also dependent on the amount of reinforcement bars in the cross-section, and hence the reinforcement bar amount is varied until the boundaries of the M-N diagram enclose the current load situation.

For the current cross-section and load situation, *figure D2*, the M-N diagram gives the following necessary residual strength;

$$\text{Load situation L1; } A_{sL1} = \underline{0} \text{ mm}^2/\text{m}$$

$$\text{Load situation L2; } A_{sL2} = \underline{150} \text{ mm}^2/\text{m}$$

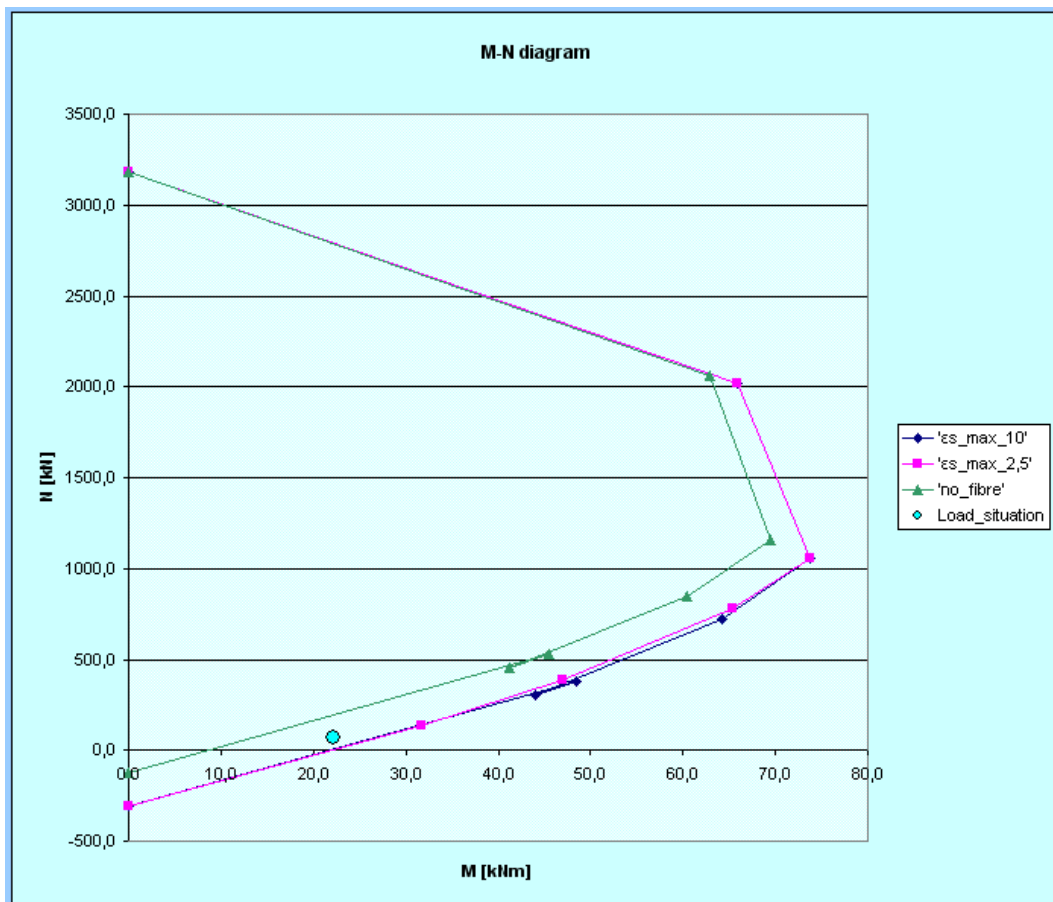

Figure D2: M-N diagram, basement wall with 1 vol.-% fibre reinforcement and 150+150mm²/m bar reinforcement.

As stated in *Chapter 3.2.4.1*, the NPG for SFRC [Several contributors, 2006] defines the following required minimum amount of vertical reinforcement for walls;

$$A_{s,\min} \geq 0.3A_c(f_{tk} - 2.7f_{tk, res})/f_{sk}$$

$$A_{s,\min} \geq 0.3 \cdot 180 \cdot 1000 \cdot (1.8 - 2.7 \cdot 1.67)/500$$

$$A_{s,\min} \geq \underline{-293}$$

$$A_s \geq A_{s,\min}$$

1Ø10 on the outer as well as the inner side of the wall gives a total bar reinforcement area equal to $A_s=157 \text{ mm}^2$.

NPG for SFRC [Several contributors, 2006] defines the following required minimum amount of horizontal reinforcement for walls;

$$A_{s,\min} \geq 0.6A_c(f_{tk} - 2.7f_{tk, res})/f_{sk}$$

$$A_{s,\min} \geq 0.6 \cdot 180 \cdot 1000 \cdot (1.8 - 2.7 \cdot 1.67)/500$$

$$A_{s,\min} \geq \underline{-586}$$

Hence, for the current situation no horizontal wall reinforcement is required.

1.4 Columns

From *Chapter 4.1.4.4*, the basement columns are subjected to a combination of bending and axial forces;

$$\text{Moment; } M_\gamma = \underline{32.6} \text{ kNm/m}$$

$$\text{Vertical load; } N_\gamma = \underline{1629} \text{ kN/m}$$

Analogous to the basement walls, also the basement columns are subjected to combined moment and axial forces, and hence the design is to be performed according to an M-N diagram. An M-N diagram for the current column is established in an Excel spreadsheet by defining 7 different failure situations for the cross-section. The shape of the M-N diagram is also dependent on the amount of reinforcement bars in the cross-section, and hence the reinforcement bar amount is varied in the Excel spreadsheet until the boundaries of the M-N diagram enclose the current load situation.

The M-N diagram in *figure D3* shows that the total reinforcement bar area necessary for the current cross-section and load situation is;

$$A_s = \underline{500} \text{ mm}^2$$

6Ø12 gives a reinforcement bar area equal to $A_s= 679 \text{ mm}^2$

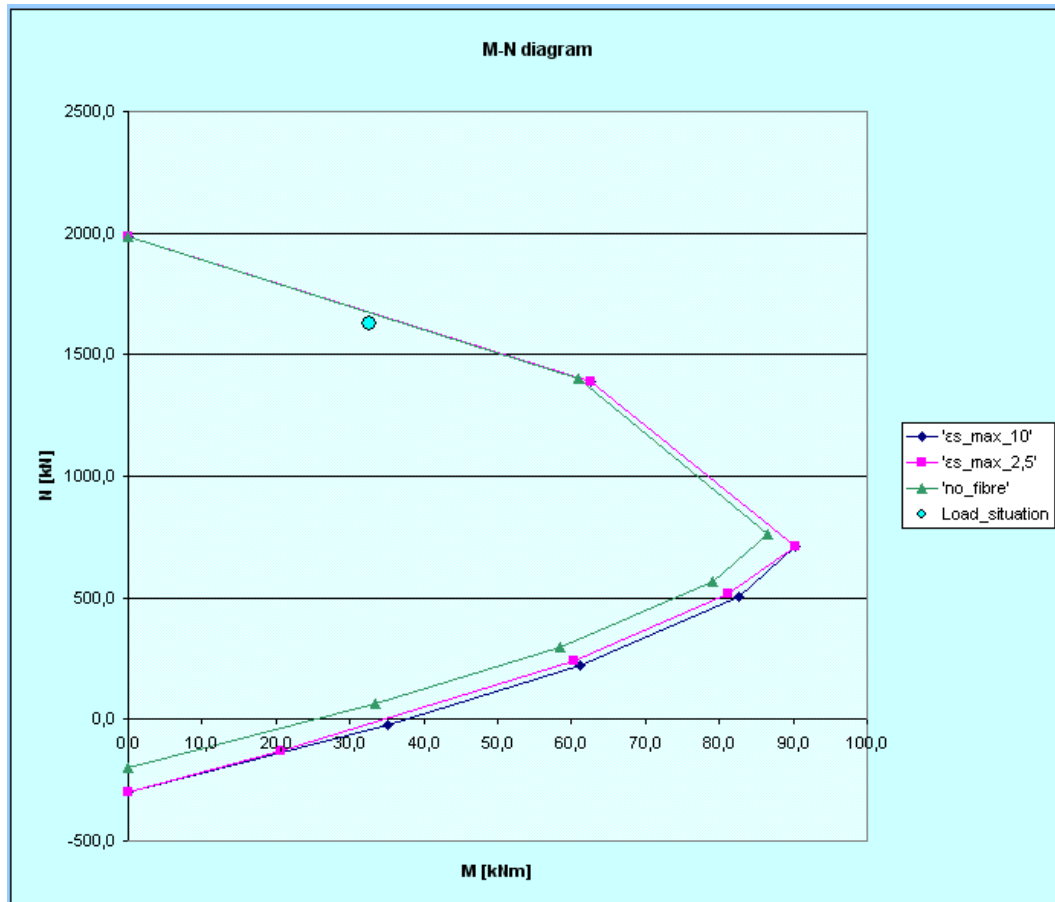

Figure D3: M-N diagram, column with 1 vol.-% fibre reinforcement and 250+250mm²/m bar reinforcement..

As stated in *Chapter 3.2.4.1*, the NPG for SFRC [Several contributors, 2006] defines that columns can be constructed without bar reinforcement if it is proven that the chosen fibre amount is sufficient to carry forces caused by load, shrinkage and temperature changes.

1.5 Slabs

The design moment of the slab is as stated in *Chapter 4.1.4.5*;

$$M_{\gamma} = \underline{85.2} \text{ kNm/m}$$

As described in *Chapter 4.1.4.5*, the moment capacity for the slab in question, reinforced with both reinforcement bars and steel fibres, is determined as follows; For a given reinforcement situation, axial equilibrium over the cross-section is demanded, and with that the depth to the neutral axis is found. Further, the design moment of resistance is found by taking moments about the neutral axis. The tensile stress in the concrete is assumed to be f_{td} , including the steel fibres' contribution to the cross-section's capacity. A spreadsheet performing the above described operation is established in Excel, and the amount of reinforcement bars is varied until the desired moment of resistance is reached. The spreadsheet results for the current foundation are shown in *figure D4*.

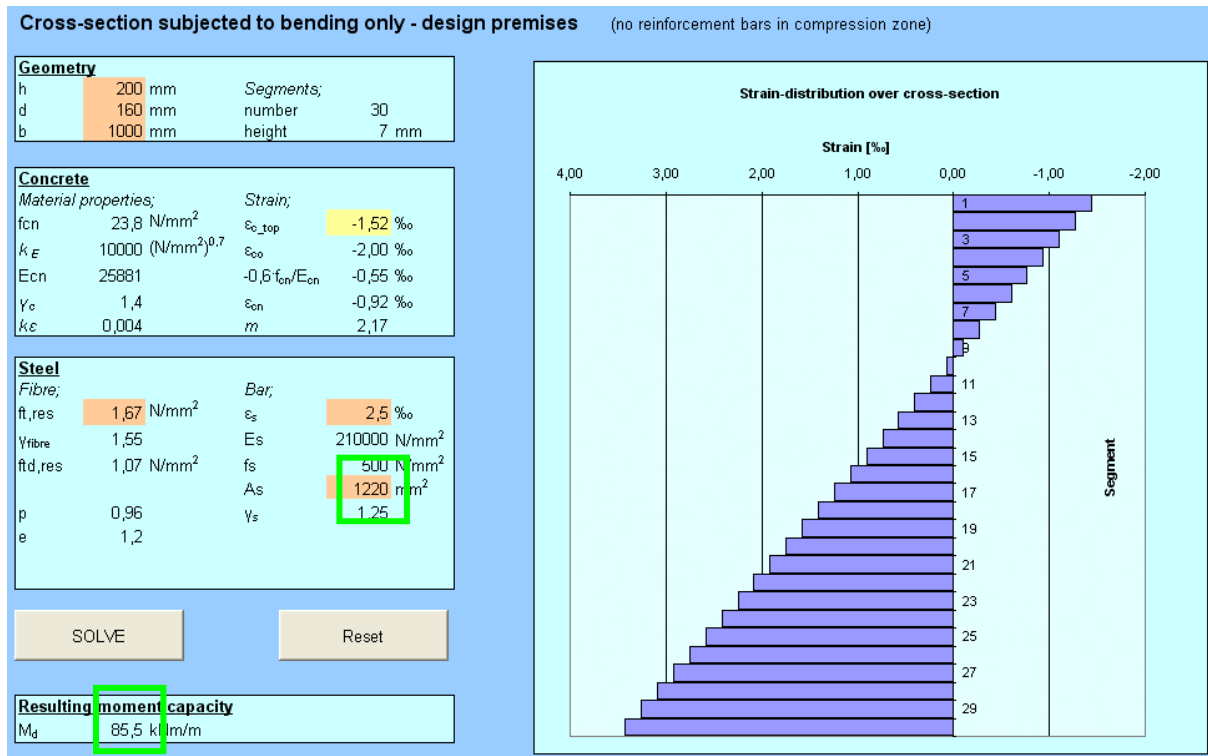

Figure D4: Required bar reinforcement when 1 vol.-% steel fibre content.

To obtain a moment of resistance equal to 85.2 kNm, the following amount of reinforcement bars is necessary;

$$A_s = 1220 \text{ mm}^2/\text{m}$$

For slabs containing reinforcement bars as well as steel fibres, the minimum required bar reinforcement is given as, Chapter 3.2.4.1;

$$A_{s,min} \geq 0.25 k_w A_c (f_{tk} - 2.7 f_{tk,res}) / f_{sk}$$

$$A_{s,min} \geq 0.25 \cdot 1.3 \cdot 1000 \cdot 200 \cdot (1.8 - 2.7 \cdot 1.67) / 500$$

$$A_{s,min} \geq -352 \text{ mm}^2$$

$$A_s \geq A_{s,min}$$

6ø16c160 gives a reinforcement bar area equal to $A_s=1257 \text{ mm}^2$

The slab's capacity for shear along its critical section, at distance d from the edge of column, is defined as:

$$V_d = V_{cd} + V_{fd} + V_{sd}$$

where V_{cd} is the shear strength of the concrete
 V_{fd} is the shear strength because of the steel fibre
 V_{sd} is the shear strength because of conventional reinforcement

According to NS 3473:2003 13.3.5.6, the total shear force capacity of the concrete, in the critical section d from the column edge, is as follows:

$$V_{cd,d} = 0.3 \cdot \left(f_{td} + \frac{k_A \cdot \rho}{\gamma_c} \right) \cdot d \cdot k_v \leq 0.6 \cdot f_{td} \cdot d \cdot k_v$$

where

$$f_{td} = f_m / \gamma_c = 1.8 / 1.4 = 1.29 \text{ N/mm}^2$$

$$k_A = 100 \text{ N/mm}^2$$

$$d = 160 \text{ mm}$$

$$\rho = A_s / (b \cdot d) = 1257 / (1000 \cdot 160) = 0.0079$$

$$\gamma_c = 1.4$$

$$k_v = 1.5 - d / d_1 = 1.5 - 0.16 = 1.34$$

$$V_{cd,d} = 0.3 \cdot \left(1.29 + \frac{100 \cdot 0.0079}{1.4} \right) \cdot 160 \cdot 1.34 \leq 0.6 \cdot 1.29 \cdot 160 \cdot 1.34$$

$$V_{cd,d} = \underline{119.3} \leq 165.9 \text{ kN/m}$$

Total shear force capacity of the concrete along the critical section, at distance d from the column edge, is;

$$V_{cd,d} = 119.3 \cdot ((0.3 + 2 \cdot 0.16) \cdot 2 + (0.4 + 2 \cdot 0.16) \cdot 2) = \underline{319.7} \text{ kN}$$

According to the NPG [Several contributors, 2006], the steel fibre's contribution to the shear force capacity of the slab is defined as:

$$V_{fd} = 0.8 \cdot f_{fd, res} \cdot b \cdot d \cdot p$$

$$V_{fd} = 0.8 \cdot 1.08 \cdot 1000 \cdot 160 \cdot 0.96 = \underline{132.7} \text{ kN/m}$$

$$V_{fd} = 132.7 \cdot ((0.3 + 2 \cdot 0.16) \cdot 2 + (0.4 + 2 \cdot 0.16) \cdot 2) = \underline{355.6} \text{ kN}$$

The total shear force capacity for the SFRC section is as follows;

$$V_d = V_{cd} + V_{fd} = 319.7 + 355.6 = \underline{675.3} > V\gamma$$

As seen above, the total shear force capacity of the foundation is larger than the design shear force affecting the slab, and consequently, there is no requirement for additional shear reinforcement.

APPENDIX E, CALCULATIONS – SOLE FIBRE REINFORCEMENT

1.1 FOUNDATIONS2
1.2 WALLS3
1.3 COLUMNS4
1.4 SLABS5

1.1 Foundations

The residual stress of SFRC is given by;

$$f_{tk,res} = \eta_0 \cdot v_f \cdot \sigma_{fk,mid}$$

where $\eta_0 = 1/3$
 $\sigma_{fk,mid} = 500 \text{ N/mm}^2$

$$f_{tk,res} = 0.333 \cdot v_f \cdot 500 = \underline{166.5 \cdot v_f}$$

According to the NPG [Several contributors, 2006], the total moment capacity of a rectangular section made of SFRC is defined as:

$$M_{ftd} = 0.4 \cdot f_{ftd,res} \cdot b \cdot h^2 \cdot p \cdot e$$

where $f_{ftd,res} = \frac{f_{tk,res}}{\gamma_m} = \frac{166.5 \cdot v_f}{1.55} = 107.4 \cdot v_f$
 $b = 1000 \text{ mm}$
 $h = 400 \text{ mm}$
 $p = 1.1 - 0.7 \cdot h \geq 0.75$
 $p = 0.82$
 $e = 1.2$

$$M_{ftd} = 0.4 \cdot 107.4 \cdot v_f \cdot 1000 \cdot 400^2 \cdot 0.82 \cdot 1.2$$

$$M_{ftd} = \underline{6760 \cdot v_f} \text{ [kNm/m]}$$

The design moment at the edge of a 300mm wide column is as stated in *Chapter 4.1.4.2*;

$$M_\gamma = \underline{160.8} \text{ kNm/m}$$

To avoid conventional bar reinforcement, the following requirement must be satisfied;

$$M_{ftd} \geq M_\gamma$$

$$6760 \cdot v_f \geq 160.8$$

$$v_f \geq 0.0238$$

$$v_f \geq \underline{2.38} \text{ vol.-%}$$

Hence, with a fibre content more than 2.38 vol.-%, no additional conventional bar reinforcement is required.

In *Chapter 4.3.4* it was found that with a fibre content of 1 vol.-%, no shear reinforcement was required. Consequently, no shear reinforcement is required with a fibre content equal to, or more than, 2.38 vol.-%.

The designing and constructing of the current foundation with fibres as sole reinforcement requires a necessary steel fibre content equal to 2.4 vol.-%.

1.2 Walls

The residual stress of SFRC is given by;

$$f_{tk,res} = \eta_0 \cdot v_f \cdot \sigma_{fk,mid}$$

where $\eta_0 = 1/3$
 $\sigma_{fk,mid} = 500 \text{ N/mm}^2$

$$f_{tk,res} = 0.333 \cdot v_f \cdot 500 = \underline{166.5 \cdot v_f}$$

From *Chapter 4.1.4*, the basement walls are subjected to a combination of bending and axial forces;

Moment – L1; $M_{\gamma L1} = \underline{22.4} \text{ kNm/m}$

Vertical load – L1; $N_{\gamma L1} = \underline{135.7} \text{ kN/m}$

Moment – L2; $M_{\gamma L2} = \underline{22.2} \text{ kNm/m}$

Vertical load – L2; $N_{\gamma L2} = \underline{72.0} \text{ kN/m}$

As described in *Chapter 4.2.2*, the design of the cross-section is to be performed according to an M-N diagram. An M-N diagram for the current wall is established in an Excel spreadsheet by defining 7 different failure situations for the cross-section. The shape of the M-N diagram is also dependent on the amount of reinforcement bars in the cross-section, as well as the residual strength of the steel fibres. The amount of reinforcement bars is set to 0, and the residual strength of the steel fibre is varied until the boundaries of the M-N diagram enclose the given load situation.

For the current cross-section and load situation, *figure E1*, the M-N diagram gives the following necessary residual strength;

$$f_{tk,res} = 2.2 \text{ N/mm}^2$$

To avoid conventional bar reinforcement, the following requirement must be satisfied;

$$166.5 \cdot v_f \geq 2.2$$

$$v_f \geq 0.0132$$

$$v_f \geq \underline{1.3} \text{ vol.-%}$$

Hence, with a fibre content more than 1.3 vol.-%, no additional conventional bar reinforcement is required.

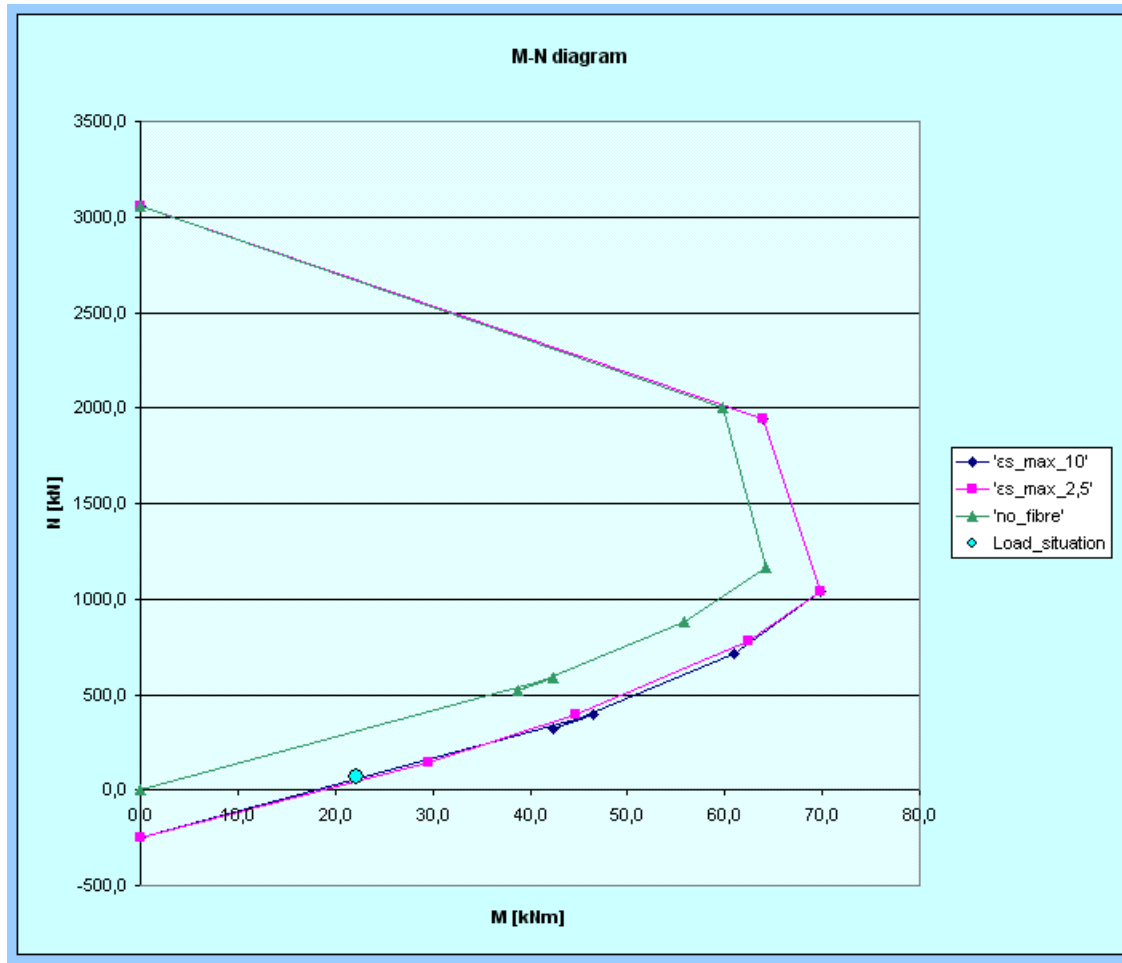

Figure E1: M-N diagram, wall with sole fibre reinforcement.

The designing and constructing of the current wall with fibres as sole reinforcement requires a necessary steel fibre volume content equal to 1.3 vol.-%.

1.3 Columns

The residual stress of SFRC is given by;

$$f_{tk, res} = \eta_0 \cdot v_f \cdot \sigma_{fk, mid}$$

where $\eta_0 = 1/3$

$$\sigma_{fk, mid} = 500 \text{ N/mm}^2$$

$$f_{tk, res} = 0.333 \cdot v_f \cdot 500 = \underline{166.5 \cdot v_f}$$

From *Chapter 4.1.4.4.*, the basement columns are subjected to a combination of bending and axial forces;

$$\text{Moment; } M_{\gamma} = \underline{32.6} \text{ kNm/m}$$

$$\text{Vertical load; } N_{\gamma} = \underline{1629} \text{ kN/m}$$

Analogous to the basement walls, also the basement columns are subjected to a combination of bending and axial forces, and hence, the design of the cross-section is to be performed according to an M-N diagram. In the M-N-diagram established in *Chapter 4.2.3*, the amount of reinforcement bars is set to 0, and the residual strength of the steel fibre is then varied until the boundaries of the M-N diagram enclose the given load situation.

The M-N diagram in *figure E2* shows that it is not possible to design and construct the current column for the given load situation with fibres as sole reinforcement. The column is subjected to such large axial compression forces that compression reinforcement is necessary.

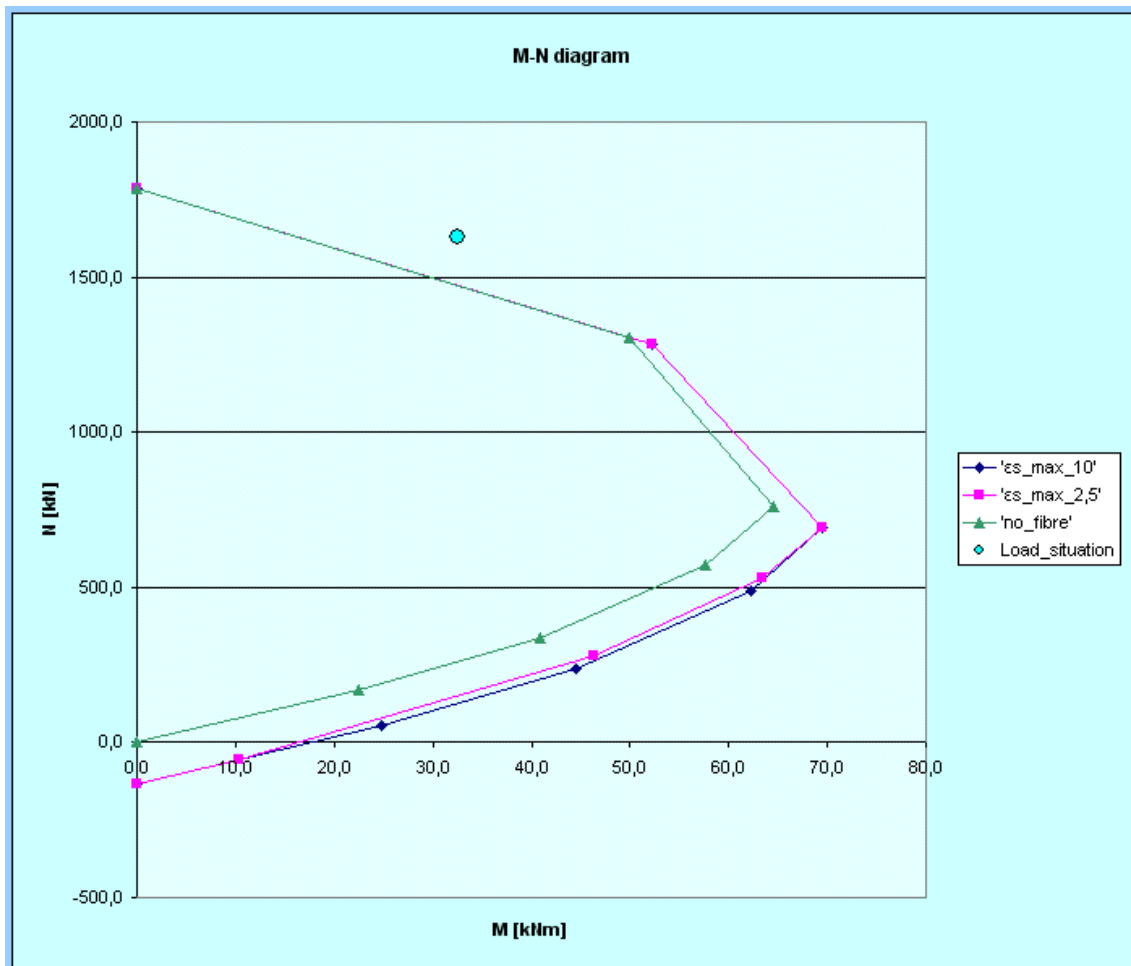

Figure E2: M-N diagram, column with sole fibre reinforcement.

1.4 Slabs

The residual stress of SFRC is given by;

$$f_{tk,res} = \eta_0 \cdot v_f \cdot \sigma_{fk,mid}$$

where $\eta_0 = 1/3$
 $\sigma_{fk,mid} = 500 \text{ N/mm}^2$

$$f_{tk,res} = 0.333 \cdot v_f \cdot 500 = \underline{166.5 \cdot v_f}$$

According to the NPG [Several contributors, 2006], the total moment capacity of a rectangular section made of SFRC is defined as:

$$M_{ftd} = 0.4 \cdot f_{ftd,res} \cdot b \cdot h^2 \cdot p \cdot e$$

where $f_{ftd,res} = \frac{f_{tk,res}}{\gamma_m} = \frac{166.5 \cdot v_f}{1.55} = 107.4 \cdot v_f$
 $b = 1000 \text{ mm}$
 $h = 200 \text{ mm}$
 $p = 1.1 - 0.7 \cdot h \geq 0.75$
 $p = 0.96$
 $e = 1.0$

$$M_{ftd} = 0.4 \cdot 107.4 \cdot v_f \cdot 1000 \cdot 200^2 \cdot 0.96 \cdot 1.0$$

$$M_{ftd} = \underline{1650 \cdot v_f} \text{ [kNm/m]}$$

The design moment of the slab is as stated in *Chapter 4.1.4.5*;

$$M_\gamma = \underline{85.2} \text{ kNm/m}$$

To avoid conventional bar reinforcement, the following requirement must be satisfied;

$$M_{ftd} \geq M_\gamma$$

$$1650 \cdot v_f \geq 85.2$$

$$v_f \geq 0.052$$

$$v_f \geq \underline{5.2} \text{ vol.-%}$$

Hence, with a fibre content more than 5.2 vol.-%, no additional conventional bar reinforcement is required.

In *Chapter 4.3.5*, it was found that with a fibre content of 1 vol.-%, no shear reinforcement was required. Consequently, no shear reinforcement is required with a fibre content equal to, or more than, 5.2 vol.-%.

The designing and constructing of the current slab with fibres as sole reinforcement requires a necessary steel fibre content equal to 5.2 vol.-%.

APPENDIX F, CALCULATIONS – DESIGN MOMENT SLAB

1.1 DESIGN MOMENT - SLAB 2
1.2 FLATEDEKKE-CALCULATIONS 3

1.1 Design moment - slab

From an analysis performed in Flatedekke, *Chapter 1.2*, the design moment in the slab is found above the support on the upper side of the slab. The design moment is found to be 91 kNm/m directly above the support, further 73 kNm/m and 75 kNm/m on each side, *figure F1*. The load expanse is found to be 667mm, 667mm and 696mm respectively, *figure F2*.

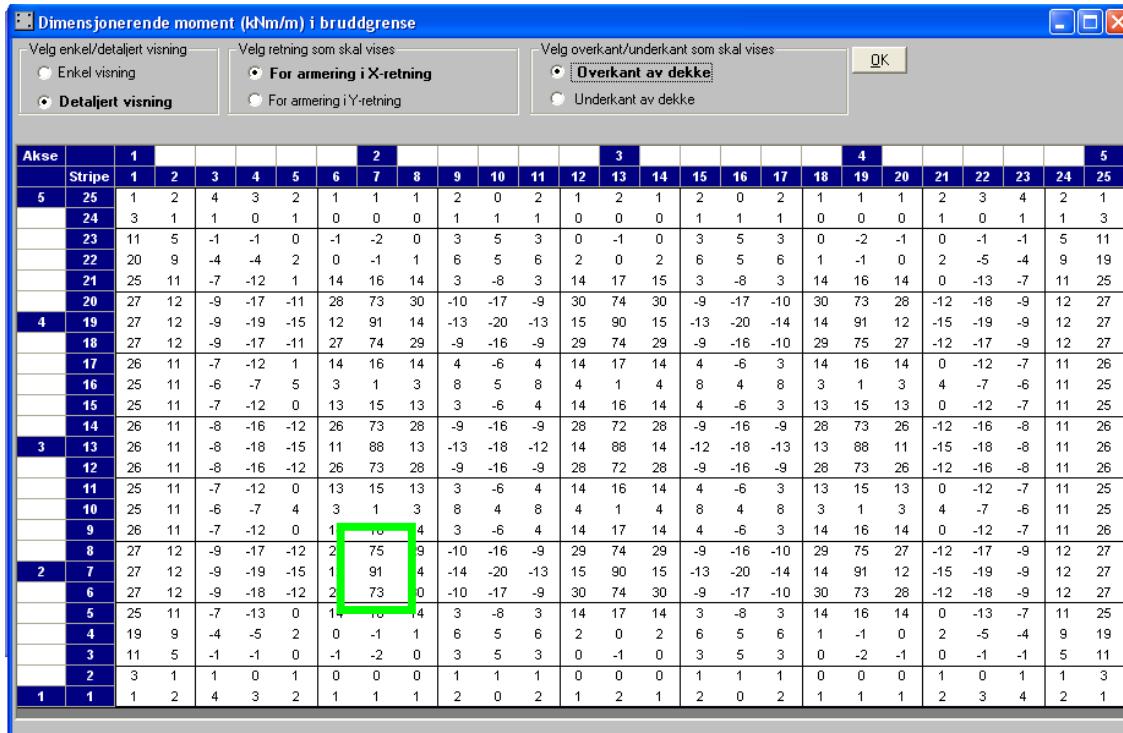

Figure F1: Design moment distribution

1. Modulnett				Alle akser i y-retning			
Alle akser i x-retning				Hoved-akse	Akser nr (i)	X-verdi (mm)	Stripe-bredde
1	1	100	200	1	1	100	200
	2	548	696		2	548	696
	3	1592	1392		3	1592	1392
	4	2983	1392		4	2983	1392
	5	4375	1392		5	4375	1392
	6	5419	696		6	5419	696
2	7	6100	667	2	7	6100	667
	8	6767	667		8	6767	667
	9	7767	1333		9	7767	1333
	10	9100	1333		10	9100	1333
	11	10433	1333		11	10433	1333
	12	11433	667		12	11433	667
3	13	12100	667	3	13	12100	667
	14	12767	667		14	12767	667
	15	13767	1333		15	13767	1333
	16	15100	1333		16	15100	1333
	17	16433	1333		17	16433	1333
	18	17433	667		18	17433	667
4	19	18100	667	4	19	18100	667
	20	18781	696		20	18781	696
	21	19825	1392		21	19825	1392
	22	21217	1392		22	21217	1392
	23	22608	1392		23	22608	1392
	24	23652	696		24	23652	696
5	25	24100	200	5	25	24100	200

Figure F2: Modular grid

Consequently, the design moment for the slab is;

$$M_d = 91 \cdot 0.667 + 73 \cdot 0.1665 + 75 \cdot 0.1665 = \underline{85.2} \text{ kNm/m}$$

1.2 Flatedekke-calculations

The calculations from Flatedekke are presented in the following pages.

SINTEF Building and Infrastructure is the third largest building research institute in Europe. Our objective is to promote environmentally friendly, cost-effective products and solutions within the built environment. SINTEF Building and Infrastructure is Norway's leading provider of research-based knowledge to the construction sector. Through our activity in research and development, we have established a unique platform for disseminating knowledge throughout a large part of the construction industry.

COIN – Concrete Innovation Center is a Center for Research based Innovation (CRI) initiated by the Research Council of Norway. The vision of COIN is creation of more attractive concrete buildings and constructions. The primary goal is to fulfill this vision by bringing the development a major leap forward by long-term research in close alliances with the industry regarding advanced materials, efficient construction techniques and new design concepts combined with more environmentally friendly material production.

